

Magstar MP 3570 Tape Subsystem

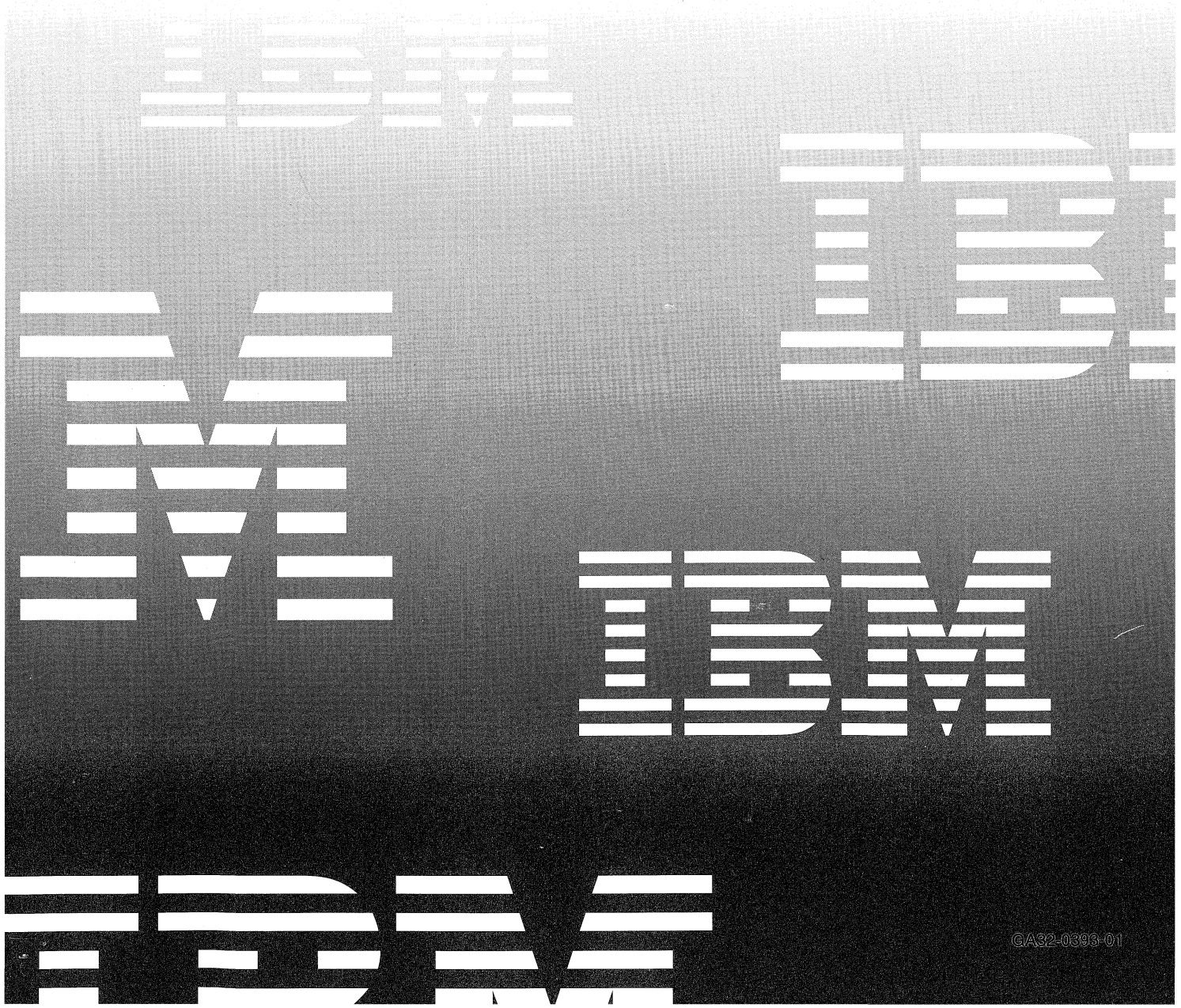

# Operator Guide

*C-Series Models*





Magstar MP 3570 Tape Subsystem

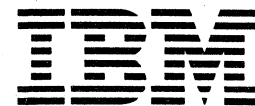

# Operator Guide

*C-Series Models*

**Note**

Before using this information and the product that it supports, be sure to read the general information under "Notices" on page xi.

**Second Edition (January 1999)**

| This edition, GA32-0393-01, is a revision to GA32-0393-00, which is now obsolete. Changes or additions are indicated by a vertical  
| line to the left of the change.

The following paragraph does not apply to any country where such provisions are inconsistent with local law.

INTERNATIONAL BUSINESS MACHINES CORPORATION PROVIDES THIS PUBLICATION "AS IS" WITHOUT WARRANTY OF ANY KIND, EITHER EXPRESS OR IMPLIED, INCLUDING BUT NOT LIMITED TO THE IMPLIED WARRANTIES OF MERCHANTABILITY OR FITNESS FOR A PARTICULAR PURPOSE.

Some states do not allow disclaimer of express or implied warranties in certain transactions; therefore, this statement may not apply to you.

Order publications from your IBM representative or the IBM branch office serving your locality. Publications are not stocked at the address given below. A comment form is provided at the back of this publication. Either mail the completed form or fax it to (520) 799-2906. If the form has been removed, then address your comments about this book to:

IBM Corporation, Department 61C, 9000 South Rita Road, Tucson, Arizona 85744-0001, U.S.A.

When you send information to IBM, you grant IBM a nonexclusive right to use or distribute the information in any way it believes appropriate without incurring any obligation to you.

© Copyright International Business Machines Corporation 1998, 1999. All rights reserved.

Note to U.S. Government Users — Documentation related to restricted rights — Use, duplication or disclosure is subject to restrictions set forth in GSA ADP Schedule Contract with IBM Corp.

---

# Contents

<b>Notices</b> .....	xi
Do You Have Comments or Suggestions? .....	xi
Safety Notices .....	xi
Possible Safety Hazards .....	xiii
Environmental Notices .....	xiv
End of Life (EOL) Plan .....	xiv
Terminology .....	xiv
Trademarks .....	xiv
IBM Agreement for Licensed Internal Code .....	xv
Communications Statements .....	xvi
<b>Preface</b> .....	xix
Organization .....	xix
Magstar MP Publications .....	xx
<b>Chapter 1. Introduction</b> .....	1
Compatibility with other Magstar MP Tape Drives .....	4
Magstar MP Bar Code Reader .....	4
<b>Chapter 2. Magstar MP 3570 Tape Subsystem</b> .....	5
Magstar MP Fast Access Linear Tape Cartridge .....	5
Cartridge Magazine .....	7
Modes of Operation .....	7
Performance .....	8
<b>Chapter 3. Quick Reference for Stand-alone Drive Model C00</b> .....	9
How Do I...? .....	9
Helpful Hints for Resolving Problems .....	10
<b>Chapter 4. Installing the Model C00</b> .....	13
Before You Begin .....	14
Pre-installation Checklist .....	16
If You Need Additional Media .....	17
Attaching the Pedestal .....	18
Subsystem Placement .....	18
Setting the SCSI Address .....	19
Host (Initiator) Connection .....	21
Removing or Relocating Model C00 .....	27
<b>Chapter 5. Operating the Model C00</b> .....	29
Drive Indicators and Operator Controls .....	29
LED Indicator Combinations .....	30
Ready Indicator .....	31
Loading a Cartridge .....	31
Unloading a Cartridge .....	31
Unload/Load Maintenance Cycle .....	31
Removing a Stuck Cartridge .....	32
Cleaning the Tape Path .....	34
<b>Chapter 6. Quick Reference for the Library Models</b> .....	35

How Do I...?	35
Helpful Hints for Resolving Problems	37
<b>Chapter 7. Installing the Models C01 and C02</b>	41
Before You Begin	42
Models C01 and C02 in Base Configuration	44
Model C02 in Split Configuration	44
Pre-installation Checklist	45
If You Need Additional Media	47
Attaching the Pedestal	48
Subsystem Placement	48
Verifying Operability of the Library Unit	49
Setting the SCSI Address and Configuring the Library	55
Host (Initiator) Connection	58
Model C01 Connections	59
Model C02 Connections	61
Completing Connections for Model C01 or C02	69
Removing or Relocating Models C01 or C02	71
<b>Chapter 8. Customer Installed Rack-Mounted Models C21 and C22</b>	73
Install Supporting Slides and Tray	78
Installing the Rack-Mounted 3570	82
Attaching SCSI and Power Cables to Models C21 and C22	85
Attaching SCSI and Power Cables to Model C21 (Single Drive with Single Host)	86
Attaching SCSI and Power Cables to Model C22 (Dual-Drive Single-Host)	89
Attaching SCSI and Power Cables to Model C22 (Dual-Drive Split-Host)	92
Installation Checkout	95
Verifying Operability of the Library Unit for Models C21 and C22	95
Setting the SCSI Address and Configuring the Library for Models C21 and C22	101
Installing the Adaptec Adapter to the Host	104
Review and Additional SCSI Device Connections for Models C21 and C22	108
Removing or Relocating Models C21 and C22	113
<b>Chapter 9. Operating the Library</b>	115
Library Modes of Operation	115
Random Mode	115
Automatic (Sequential) Mode	116
Manual (Sequential) Mode	116
Library Configurations	117
Base Configuration Modes of Operation	117
Split Configuration Modes of Operation	118
SCSI Medium Changer Addressing for Base and Split Configurations	119
Mapping Element Addresses to Physical Locations	120
Front Panel Overview	121
Power On/Off	123
Cartridge Import and Export Positions	124
Loading Cartridges into a Magazine	125
Inserting or Removing a Magazine	126
Unloading or Loading a Cartridge in a Library Magazine	128
Removing a Stuck Cartridge	129
Inserting or Removing a Cleaning Cartridge	129
Cleaning the Drive Unit Tape Path	129

Manual Cleaning	130
Setting Automatic Cleaning	130
Library Mode Selection	131
Pausing the Cartridge Sequence	131
Resetting the Cartridge Sequence	132
Library Configuration Selection	132
Clearing Tape Drive Recover Status	133
Resolving Read/Write, Media, or FID FE Error	133
Resolving Bar Code Reader Problems	133
Setting the Volume ID	134
Resolving a Mismatch Between the Bar Code Label and VOLSER	135
Operator Panel Overview	135
Status Screen	137
Line 1:	138
Line 2:	139
Line 3:	139
Line 4:	140
Intervention Screens	141
Resolving ATTENTION Messages	142
Supplemental Message Screens	143
Menu Screens	143
Operator Menus	143
Options Menu	145
Drive Selection Menu	146
Cartridge Sequence Menu	146
Set Library Mode Menu	147
Edit Configuration Menu	147
Address (SCSI ID) Drive 1 or Drive 2 Menu	148
Set Library Configuration Menu	148
Automatic Cleaning Menu	149
Unload & Reset Menu	149
Services Menu	150
Change Language Menu	150
Statistics Menu	151
Show Statistics Menu	151
Clean Menu	152
Confirm Mode Change Menu	152
Recovery Menu	153
Import Export Menu	153
Updating Microcode from an AS/400	154
Updating Microcode from RS/6000 by Using TAPEUTIL	154
Updating Microcode from a Sun System	157
Updating Microcode from an HP-UX System	157
Updating Microcode from a Windows NT System	157
<b>Chapter 10. Handling the Tape Cartridge and Magazine</b>	<b>159</b>
Unpacking the Cartridges	159
Handling the Cartridges	159
Stacking the Cartridges	159
Contaminants	160
Cartridge Degaussing and Disposal	160
Damaged Cartridges	161
Cartridge Labels	161
Bar Code Format	161

Cartridge Label Cleaning .....	162
Cartridge Label Replacement .....	162
<b>Chapter 11. Cartridge Environmental Information .....</b>	<b>163</b>
Operating Environment .....	163
Storage Environment .....	163
Shipping Environment .....	164
<b>A. Media/Hardware Problem Isolation .....</b>	<b>165</b>
<b>Statement of Limited Warranty .....</b>	<b>167</b>
<b>Glossary .....</b>	<b>169</b>
<b>Index .....</b>	<b>173</b>



---

## Figures

1.	Magstar MP Model C00	2
2.	Magstar MP Models C01, C02, C11, C12, C21, and C22	2
3.	Magstar MP Tape Subsystem Models (Device Type 3570)	3
4.	Magstar MP Fast Access Linear Tape Cartridge	5
5.	Magstar MP Cartridge Differences	6
6.	Magstar MP Cartridge Magazine (Viewed from the Operator Side)	7
7.	Quick Reference for Model C00	9
8.	Available Power Cords for Magstar MP 3570 Tape Subsystem	16
9.	RISC System/6000 and AS/400 Interposers	16
10.	Attachment Features	17
11.	Magstar MP Media Supply Items	17
12.	Magstar MP Media Supply Distributors	18
13.	Removal of Model C00 Front Cover	19
14.	Setting the SCSI Address on Model C00	20
15.	SCSI Cable Feature Codes	21
16.	Installing the RISC System/6000 SCSI System Cable at the Host Initiator	21
17.	Installing the AS/400 SCSI System Cable at the Host Initiator	22
18.	Example of Attaching One SCSI Device to the Host (Initiator)	23
19.	Example of Attaching Multiple SCSI Devices to the Host	23
20.	Rear View of Model C00	24
21.	Removing the Front Cover from Model B00	27
22.	Positioning the Drive Loader for Shipping	28
23.	Model C00 Operator Panel	29
24.	Operator Actions	30
25.	Removing the Front Cover from Model C00	32
26.	Removing a Stuck Cartridge from Model C00	33
27.	Quick Reference for Library Models	35
28.	Models C01 and C02 (shown without external covers)	41
29.	Available Power Cords for Magstar MP 3570 Tape Subsystem	45
30.	RISC System/6000 and AS/400 Interposers	45
31.	Attachment Features	46
32.	IBM Magstar MP Media Supply Items	47
33.	Magstar MP Media Supply Distributors	47
34.	Front Assembly for Library Models.	49
35.	Orange Picker Stopper	50
36.	Location of Priority Cell in Library Models	52
37.	SCSI Cable Feature Codes	58
38.	Installing the RISC System/6000 SCSI System Cable at the Host (Initiator)	59
39.	Installing the AS/400 SCSI System Cable at the Host (Initiator)	59
40.	Rear View of Model C01 or C11	60
41.	Example of Attaching One SCSI Device to the Host (Initiator)	61
42.	Example of Attaching Multiple SCSI Devices to the Host	61
43.	Rear View of Model C02 or C12	63
44.	Example of Attaching One SCSI Device to the Host (Initiator)	64
45.	Example of Attaching Multiple SCSI Devices to a Host (Initiator)	64
46.	Attaching Magstar MP Models C02 or C12 In Split Configuration	65
47.	Base Configuration	66
48.	Split Configuration (single host, one IOP, one port)	66
49.	Split Configuration (single host, one IOP, both ports)	67
50.	Split Configuration (two hosts)	67

51.	Split Configuration (single host, two IOPs)	68
52.	3570 Drive Models C21 and C22 Rack-Mounted Hardware Ship Group	74
53.	3570 Drive Models C21 and C22 Rack-Mounted Hardware Ship Group Parts and Tool Diagram	75
54.	3570 Drive Models C21 and C22 Rack-Mounted Hardware Ship Group Parts and Tool Listing	75
55.	EIA Specification	77
56.	Attaching Left-Hand Slide and Bracket Assembly	78
57.	Attaching Right-Hand Slide, Bracket, and Tray Assembly	80
58.	Attaching Tray to Left-Hand Slide	81
59.	Attaching the 3570 to the Rack Tray	82
60.	Attaching Cable Strain-Relief "Z" Bracket and Clamp	83
61.	Attaching Cable Arm Hinge and Bracket	84
62.	Model C21 cable Routing	86
63.	3570 and Articulated Arm Extended for Model C22 Single Drive	87
64.	Model C22 (Dual-Drive Single-Host) Cable Routing	89
65.	3570 and Articulated Arm Extended for Model C22 Dual-Drive Single-Host	90
66.	Model C22 (Dual-Drive Split-Host) Cable Routing	92
67.	3570 and Articulated Arm Extended for Model C22 Dual-Drive Dual-Host	93
68.	Front Assembly for Models C21 and C22	95
69.	Orange Picker Stopper	96
70.	Location of Priority Cell in Models C21 and C22	98
71.	Rear View of Model C21	108
72.	Example of Attaching One SCSI Device to the Host (Initiator)	109
73.	Example of Attaching Multiple SCSI Devices to the Host	109
74.	Rear View of Model C22	111
75.	Example of Attaching One SCSI Device to the Host (Initiator)	112
76.	Example of Attaching Multiple SCSI Devices to a Host (Initiator)	112
77.	Attaching Model C22 In Split Configuration	113
78.	Magstar MP Element Address	120
79.	Front Assembly for Library Models	121
80.	Magstar MP Cartridge Magazine (Viewed from the Operator Side)	124
81.	Loading a Cartridge in a Magazine (with the Operator Side Facing Down)	125
82.	Loaded and Unloaded Magazine (with the Door in the Open Position)	126
83.	Loading a Cartridge in the Library	128
84.	Magstar MP Cartridge Labels	134
85.	Operator Panel for Library Models	135
86.	Status Screen	137
87.	Error Message Example	141
88.	Attention Message Example	142
89.	Operator Menus	144
90.	Options Menu	145
91.	Drive Selection Menu	146
92.	Cartridge Sequence Menu	146
93.	Set Library Mode Menu	147
94.	Edit Configuration Menu	147
95.	Set Address (SCSI ID) Menu	148
96.	Set Configuration Menu	148
97.	Automatic Cleaning Menu	149
98.	Unload & Reset Menu	149
99.	Services Menu	150
100.	Change Language Menu	150
101.	Statistics Menu	151

	102. Show Statistics Menu . . . . .	151
	103. Clean Menu . . . . .	152
	104. Confirm Mode Change Menu . . . . .	152
	105. Recovery Menu . . . . .	153
	106. Import Export Menu . . . . .	153
	107. Magstar MP Tape Cartridge Labels . . . . .	162
	108. Tape Serial Log . . . . .	166
	109. Drive Log . . . . .	166



---

## Notices

References in this publication to IBM products, programs, or services do not imply that IBM intends to make these available in all countries in which IBM operates.

Any reference to an IBM program or other IBM product in this publication is not intended to state or imply that only IBM's program or other product may be used. Any functionally equivalent program that does not infringe any of IBM's intellectual property rights may be used instead of the IBM product. Evaluation and verification of operation in conjunction with other products, except those expressly designated by IBM, is the user's responsibility.

IBM may have patents or pending patent applications covering subject matter in this document. Furnishing this document does not give you any license to these patents. Send license inquiries, in writing, to the IBM Director of Licensing, IBM Corporation, 500 Columbus Avenue, Thornwood, NY 10594, U.S.A.

---

## Do You Have Comments or Suggestions?

Your feedback is important in helping to provide the most accurate and high-quality information. If you have comments or suggestions for improving this publication, you can send us comments electronically by using these addresses:

- Internet: [starpubs@vnet.ibm.com](mailto:starpubs@vnet.ibm.com) (or starpubs at vnet.ibm.com)
- IBMLink from U.S.A.: STARPUBS at SJEVM5
- IBMLink from Canada: STARPUBS at TORIBM
- IBM Mail Exchange: USIB3VVD at IBMAIL
- Fax from U.S.A. and Canada: 520 799-2906
- Fax from other countries: 520 799-2906

You can also mail your comments to:

IBM Corporation  
Information Development, Department 61C  
9000 South Rita Road  
Tucson, AZ 85744-0001, U.S.A.

When you send information to IBM, you grant IBM a nonexclusive right to use or distribute the information in any way it believes appropriate without incurring any obligation to you.

---

## Safety Notices

Listed below are the safety requirements for operating this product.

Each danger and caution notice contains a reference number (RSFTxxxx). Use the reference number to check the translation in *External Devices Translated Safety Notices*, SA26-7192.

## Danger Notices

A danger notice calls attention to a situation that is potentially lethal or extremely hazardous to people.



The electrical caution symbol identifies electrical hazards where extreme caution must be used.

The following danger notices appear in this publication:

**For customer install.**

### **DANGER**

**An electrical outlet that is not correctly wired could place hazardous voltage on metal parts of the system or the products that attach to the system. It is the customer's responsibility to ensure that the outlet is correctly wired and grounded to prevent an electrical shock. (RSFTD201)**

For a 3570 model installation by a service representative, refer to *IBM Magstar MP 3570 Tape Subsystem Maintenance Information, C-Series Models* for safety procedures.

### **DANGER**

**To prevent a possible electrical shock when adding or removing any devices to or from the system, ensure that the power cords for those devices are unplugged before the signal cables are connected or disconnected. If possible, disconnect all power cords from the existing system before you add or remove a device. (RSFTD203)**

### **DANGER**

**To prevent a possible electrical shock when installing the device, ensure that the power cord for that device is unplugged before installing signal cables. (RSFTD204)**

## Caution Notices

A caution notice calls attention to a situation that is potentially hazardous to people because of some existing condition.



The general caution symbol identifies conditions where caution must be used.



The weight caution symbol indicates that Magstar MP Library Model C01 weighs approximately 35 kilograms (77 pounds) and the Magstar MP Library Model C02 weighs approximately 40 kilograms (88 pounds). It takes three people to safely lift the unit.

## Attention Notices

An attention notice indicates the possibility of damage to a program, device, system, or data.

---

## Possible Safety Hazards

Possible safety hazards are:

### **Electrical**

An electrically charged frame can cause serious or lethal electrical shock.

### **Mechanical**

Hazards, such as a safety cover missing, are potentially harmful to people.

### **Chemical**

Do not use solvents, cleaners, or other chemicals not approved for use on this product.

Any of the problems listed above must be repaired before you use the Magstar MP 3570 Tape Subsystem.

---

## Environmental Notices

The following environmental information pertains to this product.

## Product Recycling

This unit contains recyclable materials. The materials should be recycled where facilities are available and according to local regulations. In some areas IBM will provide a product take-back program that ensures proper handling of the product. Contact your IBM representative for more information.

## Environmental Design

The environmental efforts that have gone into the design of this unit signifies IBM's commitment to improve the quality of its products and processes. Some of these activities include elimination of the use of CFCs, development of reusable or recyclable packaging, and reduction of manufacturing wastes.

---

## End of Life (EOL) Plan

This box is a purchased unit. Therefore, it is the sole responsibility of the purchaser to dispose of it in accordance with local laws and regulations at the time of disposal.

---

## Terminology

See "Glossary" on page 169 for definitions of terms, abbreviations, and acronyms used in this publication.

---

## Trademarks

The following terms are trademarks of the IBM Corporation in the United States or other countries or both:

AIX  
AIX/ESA  
Application System/400  
AS/400  
ESCON  
IBM  
Magstar  
RISC System/6000  
RS/6000  
System/370



---

## IBM Agreement for Licensed Internal Code

You accept the terms of this Agreement by your initial use of a machine that contains IBM Licensed Internal Code (called "Code").

These terms apply to Code used by certain machines IBM or your reseller specifies (called "Specific Machines"). International Business Machines Corporation or one of its subsidiaries ("IBM") owns copyrights in Code or has the right to license Code. IBM or a third party owns all copies of Code, including all copies made from them.

If you are the rightful possessor of a Specific Machine, IBM grants you a license to use the Code (or any replacement IBM provides) on, or in conjunction with, only the Specific Machine for which the Code is provided. IBM licenses the Code to only one rightful possessor at a time.

Under each license, IBM authorizes you to do only the following:

1. Execute the Code to enable the Specific Machine to function according to its Official Published Specifications (called "Specifications");
2. Make a backup or archival copy of the Code (unless IBM makes one available for your use), provided you reproduce the copyright notice and any other legend of ownership on the copy. You may use the copy only to replace the original, when necessary; and
3. Execute and display the Code as necessary to maintain the Specific Machine.

You agree to acquire any replacement for, or additional copy of, Code directly from IBM in accordance with IBM's standard policies and practices. You also agree to use that Code under these terms.

You may transfer possession of the Code to another party only with the transfer of the Specific Machine. If you do so, you must 1) destroy all your copies of the Code that were not provided by IBM, 2) either give the other party all your IBM-provided copies of the Code or destroy them, and 3) notify the other party of these terms. IBM licenses the other party when it accepts these terms. These terms apply to all Code you acquire from any source.

Your license terminates when you no longer rightfully possess the Specific Machine.

## Actions You May Not Take

You agree to use the Code only as authorized above. You may not do, for example, any of the following:

1. Otherwise copy, display, transfer, adapt, modify, or distribute the Code (electronically or otherwise), except as IBM may authorize in the Specific Machine's Specifications or in writing to you;
2. Reverse assemble, reverse compile, or otherwise translate the Code unless expressly permitted by applicable law without the possibility of contractual waiver;
3. Sublicense or assign the license for the Code; or
4. Lease the Code or any copy of it.

---

## Communications Statements

### **Federal Communications Commission (FCC) Statement**

This equipment has been tested and found to comply with the limits of a Class A digital device, pursuant to Part 15 of the FCC Rules. These limits are designed to provide reasonable protection against harmful interference when the equipment is operated in a commercial environment. This equipment generates, uses, and can radiate radio frequency energy and, if not installed and used in accordance with the instruction manual, may cause harmful interference to radio communications. Operation of this equipment in a residential area is likely to cause harmful interference, in which case the user will be required to correct the interference at his own expense.

Properly shielded, grounded and terminated cables and connectors must be used in order to meet FCC emission limits. IBM is not responsible for any radio or television interference caused by using other than recommended cables and connectors or by unauthorized changes or modifications to this equipment. Unauthorized changes or modifications could void the user's authority to operate the equipment.

This device complies with Part 15 of the FCC Rules. Operation is subject to the following two conditions: (1) this device may not cause harmful interference, and (2) this device must accept any interference received, including interference that may cause undesired operations.

### **The United Kingdom Telecommunications Act 1984**

This apparatus is approved under approval No. NS/G/1234/J/100003 for indirect connection to the public telecommunications systems in the United Kingdom.

### **Industry Canada Compliance Statement**

#### **Canadian Department of Communications Compliance Statement**

This equipment does not exceed Class A limits per radio noise emissions for digital apparatus, set out in the Radio Interference Regulation of the Canadian Department of Communications.

#### **Avis de conformité aux normes du ministère des Communications du Canada**

Cet équipement ne dépasse pas les limites de Classe A d'émission de bruits radioélectriques pour les appareils numériques, telles que prescrites par le Règlement sur le brouillage radioélectrique établi par le ministère des Communications du Canada.

## **European Union (EU) Electromagnetic Compatibility Directive**

This product is in conformity with the protection requirements of EU Council Directive 89/336/EEC on the approximation of the laws of the Member States relating to electromagnetic compatibility. IBM cannot accept responsibility for any failure to satisfy the protection requirements resulting from a non-recommended modification of the product, including the fitting of non-IBM option cards.

This product has been tested and found to comply with the limits for Class A Information Technology Equipment according to CISPR 22/European Standard EN 55022. The limits for Class A equipment were derived for commercial and industrial environments to provide reasonable protection against interference with licensed communication equipment.

**Attention:** This is a Class A product. In a domestic environment, this product may cause radio interference, in which case, the user may be required to take adequate measures.

## **Germany Electromagnetic Compatibility Directive**

Dieses Gerät ist berechtigt in Übereinstimmung mit dem deutschen EMVG vom 9.Nov.92 das EG-Konformitätszeichen zu führen. Der Aussteller der Konformitätserklärung ist die IBM.

Dieses Gerät erfüllt die Bedingungen der EN 55022 Klasse A. Für diese Klasse von Geräten gilt folgende Bestimmung nach dem EMVG: Geräte dürfen an Orten, für die sie nicht ausreichend entstört sind, nur mit besonderer Genehmigung des Bundesministers für Post und Telekommunikation oder des Bundesamtes für Post und Telekommunikation betrieben werden. Die Genehmigung wird erteilt, wenn keine elektromagnetischen Störungen zu erwarten sind. (Auszug aus dem EMVG vom 9.Nov.92, Para.3, Abs.4)

### **Hinweis:**

Dieses Genehmigungsverfahren ist von der Deutschen Bundespost noch nicht veröffentlicht worden.

## **Japan Voluntary Control Council Information**

この装置は、情報処理装置等電波障害自主規制協議会（VCCI）の基準に基づく第一種情報技術装置です。この装置を家庭環境で使用すると電波妨害を引き起こすことがあります。この場合には使用者が適切な対策を講ずるよう要求されることがあります。



---

## Preface

This publication contains information about installing and operating the IBM Magstar MP (Multi-Purpose) 3570 Tape Subsystem C-Series (Models C00, C01, C02, C11, and C12).

---

## Organization

- Chapter 1, “Introduction” on page 1 provides a brief overview of the Magstar MP C-Series.
- Chapter 2, “Magstar MP 3570 Tape Subsystem” on page 5 describes the following topics.
  - “Magstar MP Fast Access Linear Tape Cartridge” on page 5
  - “Cartridge Magazine” on page 7
  - “Modes of Operation” on page 7
  - “Performance” on page 8
- Chapter 3, “Quick Reference for Stand-alone Drive Model C00” on page 9 answers “How do I...?” questions about commonly performed tasks on Model C00 and contains helpful hints for resolving problems on Model C00.
- Chapter 4, “Installing the Model C00” on page 13 describes the positioning and preparation for connection of Model C00. This chapter also describes setting the SCSI address for Model C00, connecting the subsystem to the host processor (initiator), and removal or relocation of Model C00.
- Chapter 5, “Operating the Model C00” on page 29 describes the operator interface and control for Model C00, the LED indicators, how to load and unload a cartridge, as well as the process of cleaning the tape path for Model C00.
- Chapter 6, “Quick Reference for the Library Models” on page 35 answers “How do I...?” questions about commonly performed tasks on the library models, and contains helpful hints for resolving problems.
- Chapter 7, “Installing the Models C01 and C02” on page 41 describes the installation and connection of Models C01 and C02, their placement, and the procedure that confirms the transport mechanism on the library unit is operational. (Models C11 and C12 must be installed by your service representative.) This section also describes setting the SCSI address for the library models, connecting these subsystems to the host processor (initiator), and removing or relocating Models C01 or C02. (Models C11 and C12 must be removed or relocated by your service representative.)
- Chapter 9, “Operating the Library” on page 115 describes modes of operation, library configurations, the operator interface panel, the message display, the screens and menus, the operating procedures, and the loading and inserting of cartridges and magazines, as well as the process of cleaning the tape path for the library models.
- Chapter 10, “Handling the Tape Cartridge and Magazine” on page 159 describes cleaning considerations and procedures for individual tape cartridges

and cartridge magazines, data security, and care, handling, and disposal considerations for tape cartridges.

- Chapter 11, “Cartridge Environmental Information” on page 163 describes the operating, storage, and shipping environments recommended for tape cartridges.
- “Statement of Limited Warranty” on page 167 contains the IBM warranty statement.
- “Glossary” on page 169 defines the terms, abbreviations, and acronyms that are used in this publication.
- “Index” on page 173 includes keywords and terms to help retrieve information in this publication.

---

## Magstar MP Publications

For additional information about the Magstar MP 3570 Tape Subsystem, see:

- *IBM Magstar MP 3570 Tape Subsystem Introduction and Planning Guide C-Series Models*, GA32-0392
- *IBM Magstar MP 3570 Tape Subsystem Hardware Reference C-Series Models*, GA32-0394
- *IBM Magstar MP 3570 Tape Subsystem Maintenance Information, C-Series Models*

For additional information about the Magstar MP 3575 Tape Library Dataserver, see:

- *Magstar MP 3575 Tape Library Dataserver, Introduction and Planning Guide*, GA32-0380
- *Magstar MP 3575 Tape Library Dataserver, Operator Guide*, GA32-0381
- *Magstar MP 3575 Tape Library Dataserver, Hardware Reference*, GA32-0382
- *Magstar MP 3575 Tape Library Dataserver, Maintenance Information for Model L06*, PN 05H9590
- *Magstar MP 3575 Tape Library Dataserver, Maintenance Information for Models, L12, L18, L24, and L32*, PN 05H9581

## Netfinity and PC Server Publications

For information about Netfinity and the PC server, see:

- *Netfinity Rack Planning Installation Guide*, S24L-8055
- *IBM Netfinity Rack Solutions*, G221-6110
- *IBM Netfinity Systems Management*, G221-6111
- *IBM PC Servers Rack HMM Type 9306*, S83H-9585

## Related Information

For related information about the Magstar MP 3570 Tape Subsystem, see:

- *American National Standard Institute (ANSI) Small Computer System Interface-2 (SCSI-2)*, X3.131-1994
- *Care and Handling of Computer Magnetic Storage Media* by S. G. Geller, National Bureau of Standards Special Publication 500-101, for sale by the Superintendent of Documents, U.S.A. Government Printing Office, Washington, DC 20402
- *External Devices Translated Safety Notices*, SA26-7192
- *IBM General Information Installation Manual—Physical Planning*, GC22-7072
- *9309 Rack Enclosure General Information and Site Preparation*, GA24-4103
- *7015 Installation and Service Guide*, SA23-2628

## RISC System/6000 Publications

For additional information about RISC System/6000 systems, see:

- *RISC System/6000 Getting Started: Using RISC System/6000*, GC23-2521
- *RISC System/6000 Getting Started: Managing RISC System/6000*, GC23-2378
- *RISC System/6000 V4 Problem Solving Guide*, SC23-2606
- *RISC System/6000 V4 Message Guide & Reference*, SC23-2641
- *RISC System/6000 Problem Solving Guide*, SC23-2204
- *RISC System/6000 Planning for System Installation*, SA38-0508
- *RISC System/6000 Adapters, Devices, and Cable Information for Multiple Bus Systems*, SA38-0516
- *Adapters, Devices, and Cable Information for Micro Channel Bus Systems*, SA23-2764

## AS/400 Publications

For additional information about AS/400 systems, see:

- *AS/400 Physical Planning Reference*, SA41-3109 (IMPI)
- *AS/400 Physical Planning Reference*, SA41-5109 (RISC)
- *AS/400 Basic System Operation, Administration, and Problem Handling*, SC41-5206
- *AS/400 Backup and Recovery*, SC41-5304
- *Hierarchical Storage Management*, SC41-5351
- *Automated Tape Library Planning and Management Guide*, SC41-3309 (IMPI)
- *Automated Tape Library Planning and Management Guide*, SC41-5309 (RISC)
- *Backup Recovery and Media Services for AS/400*, SC41-4345
- *A Practical Approach to Managing Backup Recovery and Media Services*, SG24-4840
- *AS/400 CL Reference Guide*, SC41-5722
- *AS/400 System API Reference*, SC41-5801

## Related Software Information

For information about software related to the Magstar MP 3570 Tape Subsystem, see:

- *Basic Tape Library Support User's Guide and Reference*, SC26-7016
- *IBM SCSI Tape Drive, Medium Changer, and Library Device Drivers Installation and User's Guide*, GC35-0154

Additional publications may be ordered as required for training.

## Web Site Information

The following Web sites can be used as an alternate resource for questions or comments.

- <http://www.pc.ibm.com>
- <http://www.pc.ibm.com/support/>
- <http://www.storage.ibm.com/>



---

## Chapter 1. Introduction

Magstar MP 3570 Tape Subsystem models are compact, high-capacity, integrated storage devices that are available as stand-alone or rack-mounted units. The subsystems are well-suited for a variety of applications and thus are referred to as Magstar MP (Multi-Purpose) units.

**Note:** The 3570 Models C21 and C22 emulate 3570 Models C11 and C12.

The Magstar MP 3570 Tape Subsystem is attached to host processors that use the Small Computer System Interface (SCSI-2). It is intended for use on mid-range systems that require reliable tape support for backup, restore, archive, and data interchange operations, as well as applications that require rapid data access or high data capacity. These systems include but are not limited to the RISC System/6000®, RS/6000® SP™, AS/400® systems, Sun systems, HP-UX systems, IBM PC Servers, Netfinity systems, and other Windows NT® systems.

The Magstar MP 3570 Tape Subsystem is available as a table-top, stand-alone, drive-only unit (Model C00) (see Figure 1 on page 2), or as library Models C01, C02, C11, C12, C21, and C22 (see Figure 2 on page 2). Models C01 and C02 are stand-alone library units, and Models C11, C12, C21, and C22 are rack-mounted library units. Models C01, C11, and C21 have a single tape drive, and Models C02, C12, and C22 have two tape drives.

**Note:** The Magstar MP Tape Subsystem Models C21 and C22 are designed only for installation in the IBM Netfinity rack or the NETBAY22 rack.

All of the Magstar MP units use the Magstar MP Fast Access Linear Tape cartridges with longitudinal serpentine recording. These cartridges use a new, unique design that is approximately one half the size of IBM 3480, 3490, or 3590 tape cartridges. The new cartridge style provides two tape spools with mid-point load for fast access to the metal particle media. Each cartridge has an uncompressed data capacity of approximately 5GB (1 gigabyte equals 1 000 000 000 bytes) and a compressed capacity of 15GB with 3:1 data compression. There are two versions of the cartridges, the original B-Format and the newer, C-Format. For detailed performance information of each type, see "Performance" on page 8. The average load and initialize time is 8 seconds, and the average search time to data for a loaded cartridge is 8 seconds. Each tape drive in a Magstar MP subsystem contains a mechanical assembly for moving the tape, electronic circuitry for reading and writing, and microprocessors that control tape functions.

Model C00 consists of one tape drive, the integrated microprocessor control unit, and all necessary power and cooling components. The unit attaches to a host processor through a differential SCSI-2 channel adapter. The integrated control unit contains the electronics and microcode for reading and writing data. The control unit functions include management of the data buffer, error recovery procedures, and the control of all tape drive operations and some channel operations. The Model C00 tape drive contains a compact loading mechanism that handles the Magstar MP Fast Access Linear Tape cartridges. The operator communications and the message interface are handled by a combination of three LED indicators.

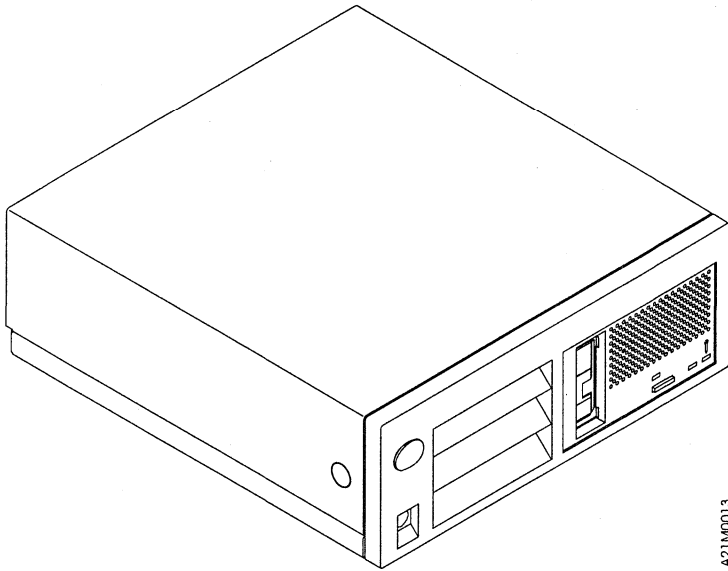

A21M0013

Figure 1. Magstar MP Model C00

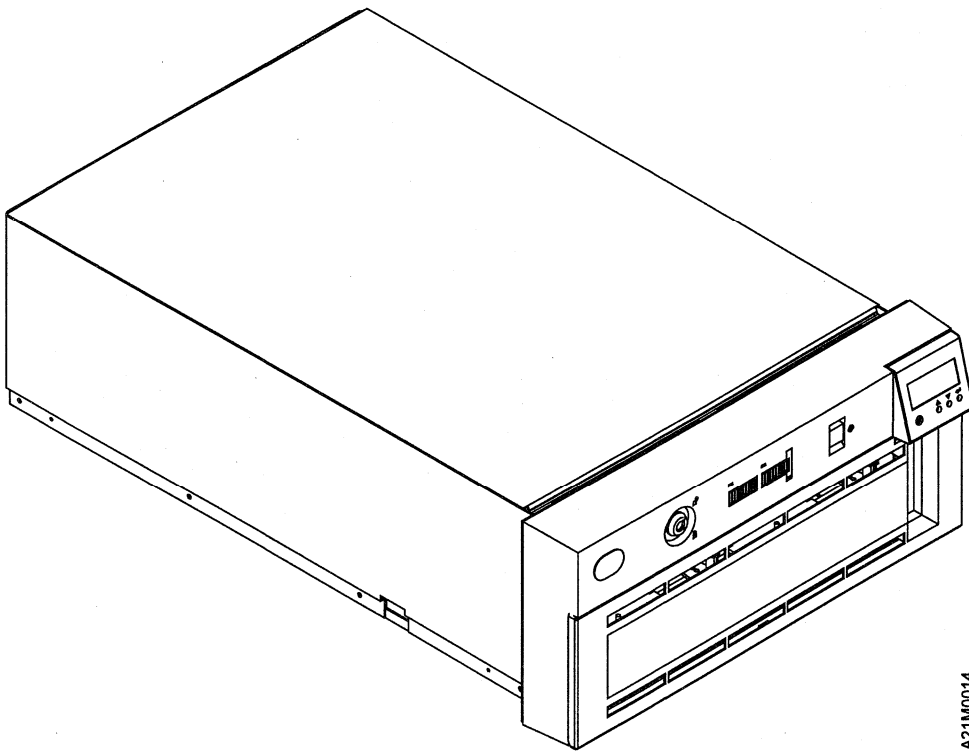

A21M0014

**Note:** Model C21 and C22 are modified to fit in the Netfinity rack.

Figure 2. Magstar MP Models C01, C02, C11, C12, C21, and C22

The library models each contain two removable 10-cartridge magazines and use a cartridge loading and transport mechanism to move the tapes to and from the storage magazines and the tape drive. Each library unit has an operator panel with buttons and a display. The operator panel is the interface for all operator functions. Each library unit can operate in automatic, manual, or random mode (see "Library Modes of Operation" on page 115). The dual-drive models (Models C02, C12, and

C22 ) may operate in Base Configuration or Split Configuration as selected in the operator menus (see “Library Configurations” on page 117). With two magazines of cartridges, the Magstar MP can provide up to 300GB of online data capacity with a data transfer rate of up to 54GB per hour at maximum compression. The dual-drive models can provide up to double this data transfer rate (up to 108GB per hour at maximum compression).

The cleaning function allows the Magstar MP to maintain drive operating efficiency. The need to clean the tape head is determined by microcode.

- For Model C00, the Clean LED flashes to prompt the operator to load the cleaning cartridge (see **4** in Figure 23 on page 29). The cleaning cartridge is automatically unloaded when cleaning is complete.
- For the library models, the cleaning cartridge is stored inside the unit. Options are available on the operator panel to use the cleaning cartridge.

Figure 3 lists the available Magstar MP models (device type 3570).

<i>Figure 3. Magstar MP Tape Subsystem Models (Device Type 3570)</i>				
<b>Model</b>	<b>Type</b>	<b>Drives</b>	<b>Color</b>	<b>Cartridges</b>
C00	Stand-alone, drive-only unit (see Figure 1)	1	Black	1
C01	Stand-alone library unit (see Figure 2)	1	Black	Up to 20
C02	Stand-alone library unit (see Figure 2)	2	Black	Up to 20
C11	Rack-mounted library unit (see Figure 2)	1	Black	Up to 20
C12	Rack-mounted library unit (see Figure 2)	2	Black	Up to 20
C21	Rack-mounted library unit (Netfinity only) (see Figure 2)	1	Black	Up to 20
C22	Rack-mounted library unit (Netfinity only) (see Figure 2)	2	Black	Up to 20

---

## Compatibility with other Magstar MP Tape Drives

The Magstar MP C-Series tape drive can be distinguished from the Magstar MP B-Series tape drive by the color of the unload button on the drive front panel. The C-Series unload button is green while the B-Series unload button is blue. In order to distinguish between the newer Magstar MP C-Format tape cartridge and the original Magstar MP B-Format tape cartridge, see "Magstar MP Fast Access Linear Tape Cartridge" on page 5.

The original B-Format tape cartridges can be written, read, and interchanged between Magstar MP 3570 B-Series Tape Subsystems, Magstar MP 3570 C-Series Tape Subsystems, and all tape drives in the 3575 Tape Library Dataserver.

The newer C-Format tape cartridges can only be written, read, and interchanged between Magstar MP 3570 C-Series Tape Subsystems and the Magstar MP Model C Tape Drives feature of the 3575 Tape Library Dataserver. The C-Format tape cartridges cannot be used in Magstar MP 3570 B-Series Tape Subsystems or in Magstar MP 3570 Model B1A tape drives in a 3575 Tape Library Dataserver.

When B-Format cartridges are used in the C-Series tape drives, the tape drives operate with better performance than the B-Series tape drives. Even higher performance is achieved by using C-Format tape cartridges (see "Performance" on page 8).

---

## Magstar MP Bar Code Reader

The Bar Code Reader enables the host application software to inventory cartridges efficiently. It is part of the cartridge picker sub-assembly. It reads the bar code portion of the top cartridge label as the cartridges enter the picker. The host can issue SCSI commands to read the bar code volser.

The Bar Code Reader is provided to enhance application performance using the Magstar MP 3570 Tape Subsystem. For Standard Label tape processing, the bar code labels and internally recorded VOLSER must match. Most IBM tape management systems, like ADSM and BRMS/400, use Standard Label tape processing. See "Bar Code Format" on page 161.

The Bar Code Reader is included on all library models of the Magstar MP 3570 Tape Subsystem.

---

## Chapter 2. Magstar MP 3570 Tape Subsystem

---

### Magstar MP Fast Access Linear Tape Cartridge

Using the Magstar MP C-Format cartridges, the Magstar MP 3570 Tape Subsystem drive reads and writes data on 128 tracks per cartridge, eight tracks at a time. The subsystem uses an interleaved serpentine longitudinal recording format. The first set of eight tracks is written from the mid-point point along the length of the tape to near the end of the tape, where the head is indexed to the next set of eight tracks for return to the tape mid-point. This process continues until all 128 tracks are written, and then is repeated for the other half of the medium until the tape is full. Operation using the Magstar MP B-Format cartridges is similar to the C-Format cartridge operation, except that four tracks, instead of eight tracks, are written at a time until all 128 tracks have been written.

Data is written on or read from metal particle tape enclosed in a tape cartridge (Figure 4). The Magstar MP Fast Access Linear Tape cartridges are different from cartridges used in other IBM tape storage products, and cannot be interchanged with the media used in other IBM tape products.

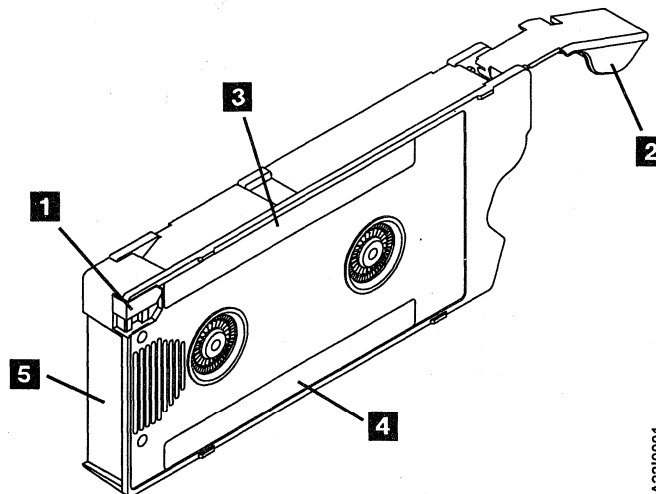

Figure 4. Magstar MP Fast Access Linear Tape Cartridge

Each tape cartridge includes a file-protect selector **1** which, when placed in the upward position as indicated, protects the tape file and prevents data from being written on it. When the file-protect selector is in the downward position, a cartridge can be overwritten. The automatic cartridge loader in the drive opens the cartridge door **2** and allows the read/write element to access the tape path.

The Magstar MP 3570 Tape Subsystem design provides faster data access than other tape technologies by eliminating the time spent threading the tape before it can be used to read or write data. In addition, the load point for the tape is near the mid-point of the tape length, with half the media wound onto each of two spools. As a result, the average distance that must be traveled to access data is one quarter of the length of the tape, which shortens the data acquisition time and reduces head wear.

The Magstar MP Fast Access Linear Tape cartridge contains major enhancements over conventional data recording cartridges. It has a rugged case that is designed for repetitive handling by automated pickers and protects the medium in an enclosed environment. The cartridge contains advanced metal-particle tape media developed for high capacity and durability. The tape never leaves the cartridge, and maintains a self-enclosed tape path that allows the medium to avoid being handled by external pickers, rollers, or external guides. The unique tape path eliminates tape thread time, reduces complexity, and provides higher reliability. The new tape path also permits quick loading and, combined with the mid-point load position, provides unparalleled tape performance.

The cartridge door remains closed during storage and handling to protect the medium and tape path from contamination.

A data cartridge has a blue or green file-protect selector (see Figure 5) and is marked IBM Magstar MP Fast Access Linear Tape. A cleaning cartridge has a gray file-protect selector and is marked IBM Magstar MP Cleaning Cartridge.

Each data cartridge is identified by a factory-applied volume serial (volser) number and a bar code. The volser and bar code appear on a label (see **3** in Figure 4) along the edges of both the data and cleaning cartridges. Label **3** also has a small space in which the operator may write a note. When setting the volser or Volume ID at the host, use the six characters, following the “F” or “G”, that are printed on the barcode label **3**. See “Setting the Volume ID” on page 134.

**Note:** Do not write on, mark over, or otherwise obscure either of the bar codes on a cartridge; doing so may cause the system to malfunction.

Another label is placed on the cartridge along the bottom of the plastic face (see **4** in Figure 4). It is marked IBM Magstar MP Fast Access Linear Tape (or IBM Magstar MP Cleaning Cartridge in the case of a cleaning cartridge). The C-Format cartridge includes the words “C-Format” on this label.

<i>Figure 5. Magstar MP Cartridge Differences</i>		
<b>Description</b>	<b>BarCode/Volser Label</b>	<b>File protect switch and Label Lettering Color</b>
Magstar MP Cleaning Cartridge	FCLNxxx	Gray
Magstar MP B-Format Data Cartridge	Fxxxxxx	Blue
Magstar MP C-Format Data Cartridge	Gxxxxxx	Green

**Attention:** User-supplied labels should not be affixed to the cartridge because they may interfere with the proper handling of the cartridge in either the drive or the library transport mechanism.

Label **5** is located on the end of the cartridge, opposite the cartridge door, and contains a bar code identical to the one located on the top label.

If a cartridge label needs to be replaced, a kit containing enough labels for 10 cartridges can be ordered. See “If You Need Additional Media” on page 17 for more information.

---

## Cartridge Magazine

Model C00 holds only one cartridge at a time. The library models (Models C01, C02, C11, and C12) can each contain one or two 10-cartridge tape magazines; a capability of holding up to 20 cartridges.

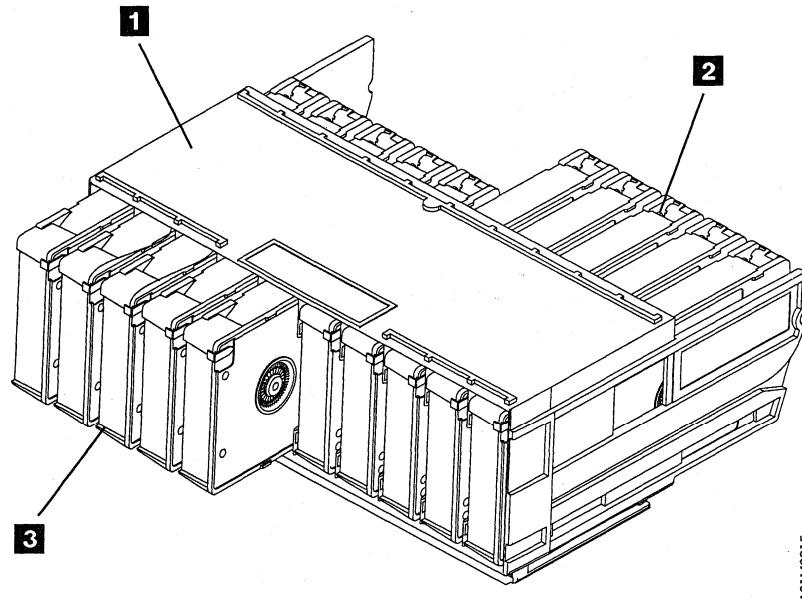

Figure 6. Magstar MP Cartridge Magazine (Viewed from the Operator Side)

As shown in Figure 6, each magazine **1** stores tape cartridges in one of 10 storage cells in two possible physical positions: the *import* position **2** or the *export* position **3**. In the import position, the cartridge transport mechanism can access the cartridge. The transport in each library unit moves processed cartridges to the export position in automatic and manual modes where they are accessible for removal by the operator.

---

## Modes of Operation

The library processes cartridges either sequentially or under the direction of the host. For sequential processing, the library is capable of operating in either automatic or manual modes, selectable at the operator panel. These two modes are identical except that, following each unload operation in manual mode, the operator must push a button to initiate the next load operation.

To process cartridges under the direction of the host (initiator), the library must be set to random mode at the operator panel.

The mode selected by the operator is stored in non-volatile memory and becomes the default mode during subsequent power-on cycles.

See “Library Modes of Operation” on page 115 for a more complete discussion of operational modes.

---

## Performance

Users who run applications that are highly dependent on tape processing speed can take advantage of the significant performance improvements provided by the Magstar MP 3570 Tape Subsystem.

Each Magstar MP 3570 C-Series Tape Subsystem drive has the following performance characteristics:

- 7MB/sec sustained data rate using Magstar MP C-Format media (native).
- 15MB/sec sustained data rate for C-Format media with maximum compression.
- 3.5MB/sec sustained data rate for B-Format media (native).
- 10.5MB/sec sustained data rate for B-Format media with 3:1 compression.
- 20MB/sec burst data rate.

**Note:** The compression ratios represent hypothetical scenarios. These values are not user-selectable, but are dependent on the data being processed. Some data will compress more efficiently than other data, and will provide a higher data throughput.

Because data transfer rates and throughput are enhanced with data compression, users can process more tape applications and run tape-related workloads faster. Users with limited time for system backup or with large amounts of disk storage can use these 3570 Tape Subsystems efficiently to back up their systems. The Magstar MP 3570 Tape Subsystem provides efficient tape operations and provides relief to users who have difficulty completing tape activities in the time available. In the event of loss or damage to files on disk storage, the high performance of the subsystem permits faster system recovery.

By using the built-in data-compression capability, the user can achieve greater data rates than the native data rate. However, the actual throughput is a function of many components, such as the host system processor, disk data rate, block size, data compression ratio, SCSI bus capabilities, and system or application software. Optimum performance can be achieved using the largest block size available. Although the Magstar MP drive is capable of up to a 15MB/sec sustained data rate, other components of the system may limit the actual effective data rate.



## Chapter 3. Quick Reference for Stand-alone Drive Model C00

This section describes some of the basic, common operations for Model C00 and contains helpful hints for resolving problems on Model C00. This section lists the most common tasks performed by the operator of the Magstar MP 3570 Tape Subsystem and describes where to find information about each task. Helpful hints for operator-level troubleshooting are also included.

### How Do I...?

Figure 7 lists the most common tasks performed by the operator of Model C00 and describes where to find information about each task.

<i>Figure 7 (Page 1 of 2). Quick Reference for Model C00</i>	
<b>How do I...</b>	<b>See...</b>
<b>Get started?</b>	Chapter 4, "Installing the Model C00" on page 13.
<b>Load a cartridge?</b>	"Loading a Cartridge" on page 31.
<b>Unload a cartridge?</b>	"Unloading a Cartridge" on page 31.
<b>Write protect a cartridge?</b>	Figure 4 on page 5.
<b>Set the SCSI address?</b>	"Setting the SCSI Address" on page 19.
<b>Read the operator LEDs?</b>	"Drive Indicators and Operator Controls" on page 29 and "LED Indicator Combinations" on page 30.
<b>Put a label on the cartridge?</b>	"Cartridge Label Replacement" on page 162.
<b>Tell a cleaning cartridge from a data cartridge?</b>	"Magstar MP Fast Access Linear Tape Cartridge" on page 5.
<b>Clean the drive tape path?</b>	"Cleaning the Tape Path" on page 34.
<b>Order additional media supplies?</b>	"If You Need Additional Media" on page 17.
<b>Decide where to locate Model C00?</b>	"Subsystem Placement" on page 18.
<b>Connect Model C00 to a host (initiator)?</b>	"Host (Initiator) Connection" on page 21.
<b>Move or relocate an installed Model C00?</b>	"Removing or Relocating Model C00" on page 27.
<b>Remove a stuck cartridge?</b>	"Removing a Stuck Cartridge" on page 32.
<b>Store cartridges?</b>	"Storage Environment" on page 163.
<b>Safely dispose of cartridges?</b>	"Cartridge Degaussing and Disposal" on page 160.
<b>Resolve Read/Write or Media Errors, or FID FE Errors?</b>	"Resolving Read/Write, Media, or FID FE Error" on page 133.
<b>Select a VOLSER or Volume ID?</b>	"Setting the Volume ID" on page 134.
<b>Update microcode in the Magstar MP?</b>	"Updating Microcode from an AS/400" on page 154, "Updating Microcode from RS/6000 by Using TAPEUTIL" on page 154, "Updating Microcode from a Sun System" on page 157, "Updating Microcode from an HP-UX System" on page 157, or "Updating Microcode from a Windows NT System" on page 157.

Figure 7 (Page 2 of 2). Quick Reference for Model C00

<b>Check the SCSI Bus?</b>	Refer to the following sections in the Common Procedures chapter of the <i>IBM Magstar MP Tape Subsystem Maintenance Information</i> for more information. <ul style="list-style-type: none"><li>• Checking SCSI Attachment in AIX Environment</li><li>• Checking SCSI Attachment in AS/400 Environment</li><li>• Checking SCSI Attachment in HP Environment</li><li>• Checking SCSI Attachment in SUN Environment</li><li>• Checking SCSI Attachment in WIN/NT Environment</li></ul>
<b>Determine SCSI Bus Problems?</b>	Refer to the <i>IBM Magstar MP Tape Subsystem Maintenance Information</i> for more information.

## Helpful Hints for Resolving Problems

Many of the problems encountered in the use of Model C00 can be resolved readily by the operator without the assistance of your service representative.

Do the following simple steps first whenever normal operation is disrupted:

- Ensure that the cartridge is properly positioned in the drive.
- Try to unload the cartridge. If a cartridge is stuck in the drive, see "Removing a Stuck Cartridge" on page 32.
- Check to see if the write-protect tab is set in the upward position to protect the tape from being written on. If you are attempting to write on the tape with the write-protect tab upward, you will experience an error condition with your software application.
- Check to ensure that the cartridge is the proper type (Magstar MP Fast Access Linear Tape).
- Check the integrity of the cartridge to see that it is properly functioning and that it is not broken or otherwise obstructed by contaminants or improperly applied user labels.
- Ensure that a cleaner cartridge has been inserted if one has been requested and, conversely, that no cleaner cartridge has been inserted if a data cartridge is required.
- Check the host software settings to make sure that compression is not enabled.
- Turn the power off and then on again.

**Note:** During normal operation the cartridge may pop out and back in. See "Unload/Load Maintenance Cycle" on page 31.

### AS/400 Hints

PTFs (Program Temporary Fix) are required prior to attaching a Magstar MP 3570 Tape Subsystem to an AS/400 system. The PTFs for all supported AS/400 releases are listed in INFO APAR II10363. This info APAR contains the most current PTF information for all supported releases and important information concerning the attachment of the Magstar MP 3570 Tape Subsystem to the AS/400.

After installing the appropriate PTFs, a SAVSYS must be done to ensure the new IOP code is available during a system recovery.

The FC 2729 adapter shares a Combined Function IOP with the communications subsystems. Resetting the 2729 will disrupt the associated communications adapters.

Whenever possible, create the Magstar MP configuration by performing an IPL of the I/O processor after attaching it to the Magstar MP. Ensure the AS/400 system value for Autoconfigure Devices is set to on. The I/O processor may be IPLed by varying off and varying on with RESET or by using the System Service Tools (STRSST). Refer to the *Application System/400 Service Functions User's Guide* for information about the System Service Tools.

Magstar MP configures as TAPxx, where xx is the number of the next device.



---

## Chapter 4. Installing the Model C00

This section describes the installation and operation procedures for Model C00. It includes the steps to follow when positioning Model C00 and preparing to connect it to the host (initiator).

**Note:** WHEN INSTALLING MODELS C01 or C02, see Chapter 7, "Installing the Models C01 and C02" on page 41.

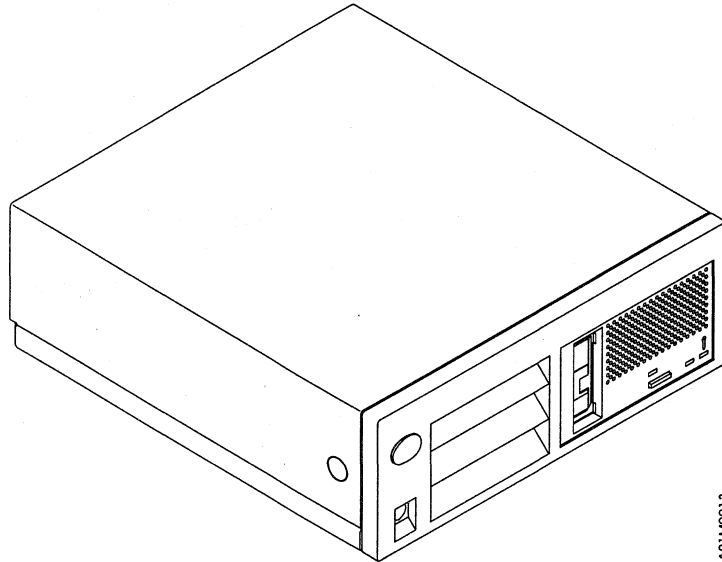

A21M0013

---

## Before You Begin

Read "Safety Notices" on page xi before proceeding.

**Note:** A #2 Phillips screwdriver may be required for installation.

See your initiator management or system hardware books to locate information that you will need to install Model C00. You may find the needed information under the following topics:

1. Installing an external SCSI tape drive.
2. SCSI controllers or host adapters.
3. External SCSI devices.

If the host system has any software or written instructions for system upgrades, use those instructions.

If there are no specific host system software aids or written instructions for system upgrades, use the following installation instructions. You may need to refer to your host system management or system hardware books to locate information you need to install the Magstar MP.

Each device on the SCSI bus must have a unique SCSI address. If no records are available as to which addresses other devices use, you must physically check them. You must also know the address of the controller card.

The Magstar MP is set to a default SCSI address of 0 at the factory. This address will work in most cases. If you need to change this preset address to avoid conflicts, see "Setting the SCSI Address" on page 19.

After you have identified the location of the SCSI controller where you will make the SCSI cable connections, complete the following steps in the sequence shown and check off each step as it is completed:

- \_\_\_ 1. Record in which slot the SCSI controller is located on the back of the host (initiator)\_\_\_\_\_.

**Note:** If attaching Model C00 to AS/400, only one Model C00 can be attached to a port. (There are two ports per type 6501 SCSI controller.)

- \_\_\_ 2. Record the SCSI address to be used for Model C00 \_\_\_\_\_.

- \_\_\_ 3. Determine the proper way to quiesce (vary offline) the SCSI port on the host (initiator) to which Model C00 will be attached.

**RS/6000 Note:**

Check that the flash memory on the SCSI adapter in the system contains the proper level of microcode. Affected machine types include any system that contains a SCSI-2 Differential F/W adapter (4-6) or SCSI-2 Enhanced Differential F/W adapter (4-C).

To determine if your machine has an adapter with downlevel microcode, type this command on an AIX prompt: **lscfg -vl ascsi\* | pg**

To determine if you have a 4-6 or 4-C SCSI adapter, look at the lines labeled **Displayable Message** and **Loadable Microcode Level**.

The **4-6** adapter will indicate:

```
Displayable Message.....SCSI-2FWSD
Loadable Microcode Level.....0010
```

The **4-C** adapter will indicate:

```
Displayable Message.....SCSI-2FWSD
Loadable Microcode Level.....0080
```

Look for the line **ROS Level and ID** which should show as:

```
ROS Level and ID .....XX
```

- For the 4-6:

**XX** should be either 67, 68, 70, 72, 73, 74, or higher.

If 74 or higher is displayed, there is no need to apply any update to the 4-6.

- For the 4-C:

**XX** should be either C4, C5, C6, or higher.

If C6 or higher is displayed, there is no need to apply any update.

Level 74 & C6 or higher microcode is strongly recommended for use with IBM Magstar MP tape drives, to ensure optimum performance and reduced errors. It may also resolve problems with other sequential SCSI devices (or devices that do not support command queueing) that are attached to dedicated F/W controllers and used in systems with multiple F/W adapters.

**AS/400 Note:**

PTFs (Program Temporary Fix) are required prior to attaching a Magstar MP 3570 Tape Subsystem to an AS/400 system. The PTFs for all supported AS/400 releases are listed in INFO APAR II10363. This info APAR contains the most current PTF information for all supported releases and important information concerning the attachment of the Magstar MP 3570 Tape Subsystem to the AS/400.

After installing the appropriate PTFs, a SAVSYS must be done to ensure the new IOP code is available during a system recovery.

The Magstar MP also attaches to the following systems:

- Hewlett Packard: 900 Series 800, /T, and /K class servers running HP-UX 10.0X through 10.3X. Other servers that support HP Precision Bus (HP-PB) fast/wide (F/W) Differential Adapter 28696A.
- Windows NT: Microsoft Windows NT Server version 4.0 with service pack 3 or greater. Intel processors require an Adaptec 2944 fast/wide SCSI adapter, Symbios Logic SYM8751D PCI SCSI Adapter, or equivalent.
- Sun Solaris: Solaris 2.3, 2.4, 2.51, and 2.6 for Sun and Sun Sparc. Requires SCSI-2 fast/wide differential adapter.

## Pre-installation Checklist

Remove the packaging material and save it for reshipment or relocation.

Check to ensure that you received the following items:

- \_\_\_ 1. Appropriate power cord (see Figure 8).

<i>Figure 8. Available Power Cords for Magstar MP 3570 Tape Subsystem</i>	
<b>Magstar MP P/N and Feature Code</b>	<b>Description</b>
46F5893 (FC 9080 and FC9986)	Watertight Plug / Power Cord, Chicago
46F5894 (FC 9080 and FC9800)	Watertight Plug / Power Cord, U.S.A.
6952300 (FC 9800)	9-ft Power Cord, 125V, 10A U.S.A./Canada
13F9979 (FC 9820)	2.7-m Power Cord, 250V, 10A France
13F9997 (FC 9821)	2.7-m Power Cord, 250V, 10A Denmark
14F0033 (FC 9825)	2.7-m Power Cord, 250V, 10A U.K.
14F0087 (FC 9827)	2.7-m Power Cord, 250V, 10A Israel
14F0051 (FC 9828)	2.7-m Power Cord, 250V, 10A Switzerland
14F0015 (FC 9829)	2.7-m Power Cord, 250V, 10A South Africa
14F0069 (FC 9830)	2.7-m Power Cord, 250V, 10A Italy
13F9940 (FC 9831)	2.7-m Power Cord, 250V, 10A Australia
1838574 (FC 9833)	9-ft Power Cord, 250V, 10A U.S.A./Canada
6952301 (FC 9986)	6-ft Power Cord, 125V, 10A Chicago
<b>Note:</b> See <i>IBM Magstar MP 3570 Tape Subsystem Introduction and Planning Guide C-Series Models</i> for additional information.	

- \_\_\_ 2. Interposer (if required) for attachment to the host (see Figure 9).

<i>Figure 9 (Page 1 of 2). RISC System/6000 and AS/400 Interposers</i>		
<b>Host</b>	<b>Host Connection</b>	<b>Magstar MP Interposer P/N and Feature Code</b>
RS/6000	PCI SCSI-2 Differential Fast/Wide Adapter (FC 2409, identifier 4-B)	None required
RS/6000	PCI SCSI-2 Differential Fast/Wide Adapter (FC 6207, identifier 4-L)	None required
RS/6000	PCI SCSI-2 Fast/Wide Differential Adapter (FC 6209, identifier 4-B)	None required
RS/6000	Enhanced SCSI-2 Differential Fast/Wide Adapter/A (FC 2412, identifier 4-C)	50G0460 (FC 2892)



*Figure 9 (Page 2 of 2). RISC System/6000 and AS/400 Interposers*

Host	Host Connection	Magstar MP Interposer P/N and Feature Code
RS/6000	SCSI-2 Differential Fast/Wide Adapter/A (FC 2416, identifier 4-6)	50G0460 (FC 2892)
RS/6000	SCSI-2 Differential Fast/Narrow High-Performance External I/O Controller (FC 2420, identifier 4-2)	61G8323 (FC 2891)
AS/400	Magnetic Media Subsystem Controller (FC 6501)	05H3834 (FC 2895)
AS/400	Magnetic Media Subsystem Controller (FC 6534)	None required
AS/400	Magnetic Media Subsystem Controller (FC 2729)	None required

- \_\_\_ 3. One cleaning cartridge (P/N 05H2463).
- \_\_\_ 4. One or more Magstar MP C-Format Fast Access Linear Tape cartridges (P/N 08L6187).
- \_\_\_ 5. One Magstar MP device driver diskette for the RS/6000, Sun, HP-UX, Windows NT, or Open System attach feature.
 

**Note:** A device driver diskette is not needed for AS/400 systems.
- \_\_\_ 6. One pedestal and attaching screw. (Pre-attached to the bottom of the unit.)
- \_\_\_ 7. An appropriate SCSI-2 cable (see Figure 10.)

*Figure 10. Attachment Features*

Magstar MP P/N and Feature Code	Description
P/N 49G6456 (FC 5205)	0.5-m (2-ft) SCSI Cable
P/N 49G6458 (FC 5212)	12-m (39-ft) SCSI Cable
P/N 49G6459 (FC 5218)	18-m (59-ft) SCSI Cable
P/N 49G6457 (FC 5245)	4.5-m (15-ft) SCSI Cable
P/N 08L6201 (FC 5225)	25.0-m (81-ft) SCSI Cable

- \_\_\_ 8. One SCSI terminator (P/N 61G8324).
- \_\_\_ 9. *IBM Magstar MP 3570 Tape Subsystem Operator Guide C-Series Models.*
- \_\_\_ 10. *Magstar MP 3570 Tape Subsystem Maintenance Information, C-Series Models.*
- \_\_\_ 11. *IBM SCSI Tape Drive, Medium Changer, and Library Device Drivers Installation and User's Guide, GC35-0154.*

## If You Need Additional Media

Figure 11 shows additional supply items available from IBM Supply Fulfillment Operations.

*Figure 11 (Page 1 of 2). Magstar MP Media Supply Items*

Part Number	Description
05H2463	Cleaner Cartridge
05H2462	B-Format Data Cartridge
08L6187	C-Format Data Cartridge

<i>Figure 11 (Page 2 of 2). Magstar MP Media Supply Items</i>	
<b>Part Number</b>	<b>Description</b>
08L6191	C-Format Replacement Label Kit - 10 Sets of Labels
05H9393	B-Format Replacement Label Kit - 10 Sets of Labels

For additional Magstar MP data cartridges, cleaning cartridges, and labels, contact the appropriate distributor for your location as given in Figure 12.

<i>Figure 12. Magstar MP Media Supply Distributors</i>		
<b>Location</b>	<b>Contact</b>	<b>Telephone Number</b>
United States, Canada, Puerto Rico	IBM Media Distribution North America	888-IBM-MEDIA
Central America	General Business Machines	+1-305-539-3470
Spain	IBM Supplies Distribution Europe	900 983131
Italy	IBM Supplies Distribution Europe	1678 78349
France	IBM Supplies Distribution Europe	0590 5871
Germany	IBM Supplies Distribution Europe	0130 818 005
Sweden	IBM Supplies Distribution Europe	0207 94270
Norway	IBM Supplies Distribution Europe	800 11389
Denmark	IBM Supplies Distribution Europe	800 15534
Finland	IBM Supplies Distribution Europe	08001 13110
United Kingdom	IBM Supplies Distribution Europe	0800 968679
Elsewhere in Europe, Middle East, and Africa	IBM Supplies Distribution Europe	+31 433 502 756 (voice) +31 433 262 292 (fax)
Japan	Supply Services, IBM Japan, Ltd.	03-3546-7611

---

## Attaching the Pedestal

If Model C00 will be used in a vertical orientation, attach the pedestal to the side of Model C00 with a single screw. If the pedestal came pre-attached to the unit, loosen the screw and rotate the pedestal 90° for vertical orientation.

---

## Subsystem Placement

Model C00 can be located anywhere that is convenient to the operator (subject to the following restrictions):

1. The power cord and the SCSI cable must be the appropriate length (see Figure 15 on page 21).
2. Model C00 should not be placed in a dusty location.
3. Do not stack more than one Magstar MP 3570 Tape Subsystem on top of another.

4. Do not block the vents on the subsystem chassis.
5. The Model C00 orientation may be either vertical (with the cartridge loader cell horizontal and the power switch near the bottom) or horizontal (with the cartridge loader cell vertical).

---

## Setting the SCSI Address

The SCSI address switch is used to set the SCSI address that uniquely identifies Model C00 to the initiator on the selected SCSI bus.

1. Be sure the Power switch for Model C00 is set to the Off position. The switch is off when it is in the out position and even with the front cover surface (see **1** in Figure 23 on page 29).
2. Remove the front cover to expose the drive with its drive cover by pressing the buttons on each side of the front cover and pulling forward (see **1** and **2** in Figure 13).

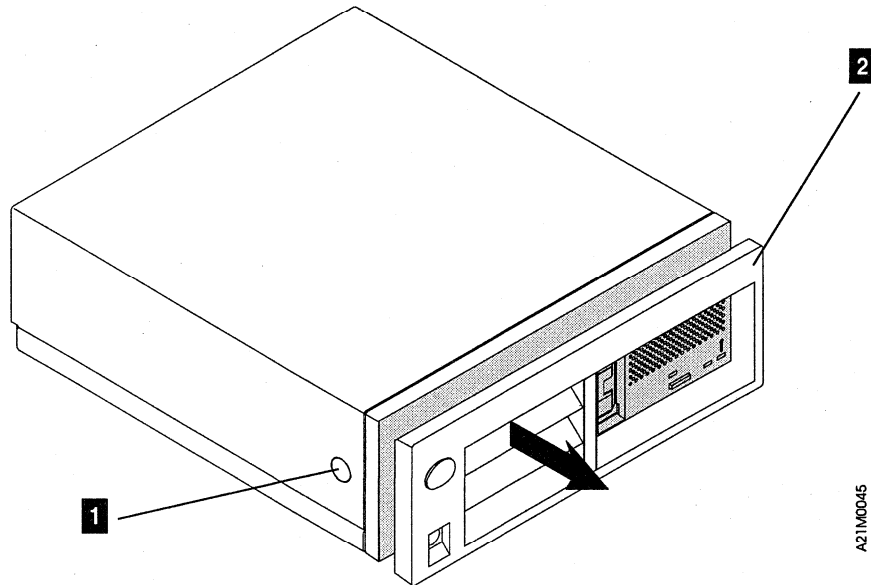

Figure 13. Removal of Model C00 Front Cover

**Note:** There is a corresponding tab on the opposite side of the chassis to the one shown as **1** in Figure 13.

Be sure to observe the detents in the chassis as you pull away the front cover.

- 3. Remove the drive cover (see **3** in Figure 14) by pressing the top center of the drive cover and pulling it from the front of the drive (see **2** in Figure 14).
- 4. Set the rotary SCSI address switch (see **4** in Figure 14), located in the upper right corner, near the drive gear (see **1** in Figure 14), to the specified address. The switch is set to 0 at the factory.

**Notes:**

- a. Use the SCSI address you have previously selected and recorded per the instructions and checklist in “Before You Begin” on page 14.
  - b. For connection to AS/400, it is recommended that the SCSI address switch be set to 0.
- 5. Replace the drive cover securely onto the front of the drive. Tilt the top of the drive cover forward to engage the top catch first. Then swing the drive cover downward and snap it into place. You will hear two clicks as the two bottom catches snap into the slots in the drive chassis.

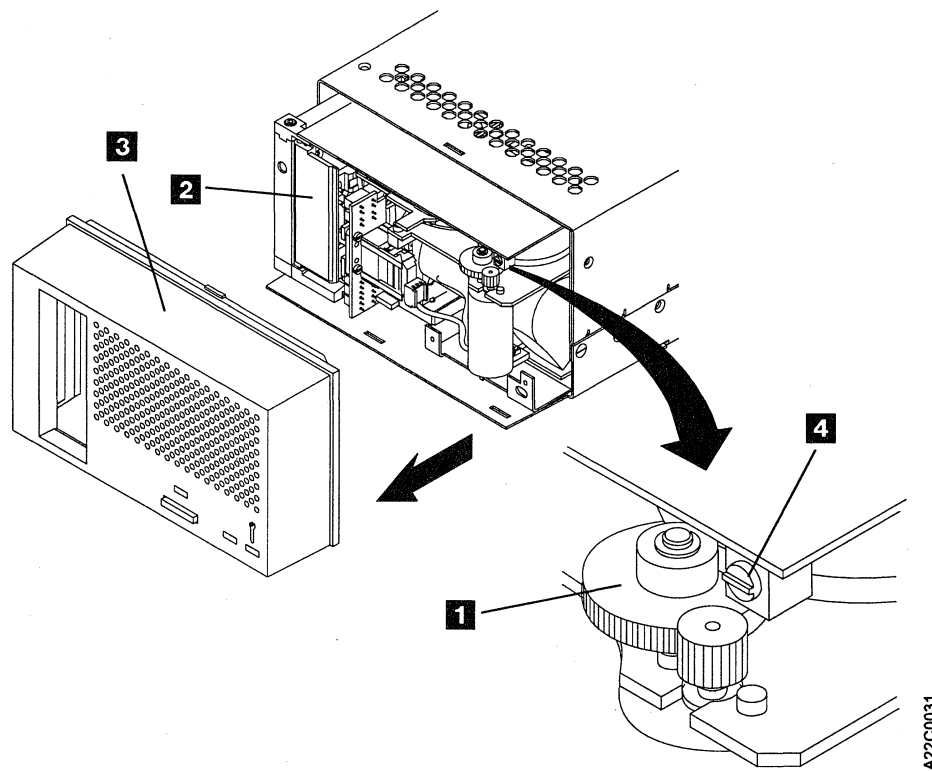

Figure 14. Setting the SCSI Address on Model C00

- 6. Replace the front cover on the device; pay attention to the detents in the chassis.
- 7. Proceed with Host (Initiator) Connection.

## Host (Initiator) Connection

The host (initiator) SCSI port must be quiesced (varied offline) before adding or removing any SCSI device. AS/400 system feature code 6501 provides two ports. Each 6501 port can support one Magstar MP Tape Subsystem. For optimum performance, there should only be one Magstar MP subsystem attached to each AS/400 feature 6501. An AS/400 system cannot be interconnected with any other system (including another AS/400) on the same SCSI bus.

1. An interposer may be required at the host end of the SCSI cable (see Figure 9 on page 16). If so, install the appropriate interposer at the initiator (the host port where SCSI cable will be attached). Attach the interposer securely to the host adapter before attaching the SCSI cable.

See Figure 15 for SCSI cable feature codes. See Figure 16 for SCSI cable connections to the host.

*Figure 15. SCSI Cable Feature Codes*

Magstar MP Feature Code and P/N	Cable Length
FC 5205 (P/N 49G6456)	0.5 m (2 ft)
FC 5212 (P/N 49G6458)	12 m (39 ft)
FC 5218 (P/N 49G6459)	18 m (59 ft)
FC 5225 (P/N 08L6201)	25 m (81 ft)
FC 5245 (P/N 49G6457)	4.5 m (15 ft)

**Notes:**

1. Cable lengths greater than 18 m (59 ft) cannot be used with RS/6000 controller FC 2420. Cable lengths up to 25 m (81 ft) can be used with RS/6000 controller FC 2409, 2412, 2416 or 6209.
2. On AS/400 systems, cable lengths up to 25 m (81 ft) can be used with feature code 2729, 6501, and 6534.

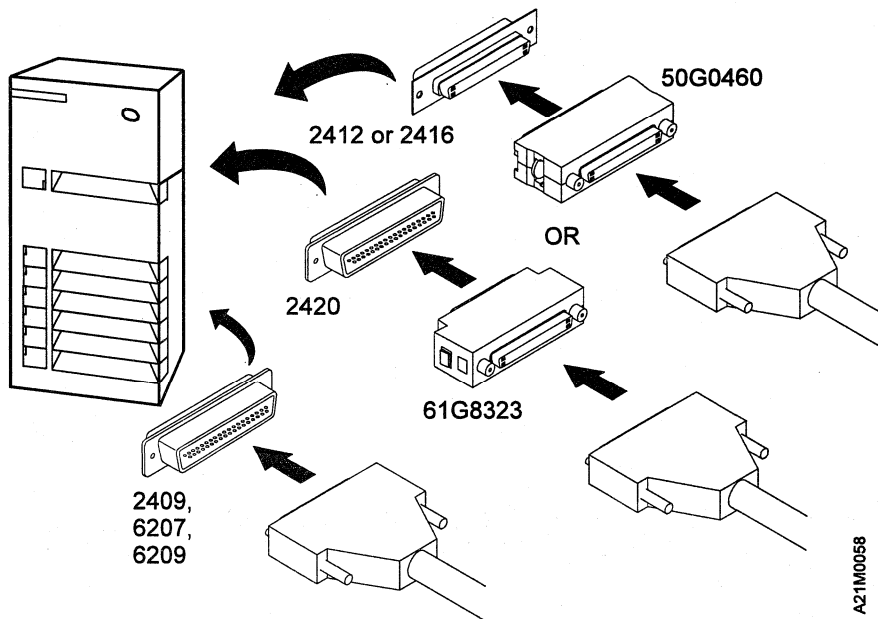

*Figure 16. Installing the RISC System/6000 SCSI System Cable at the Host Initiator*

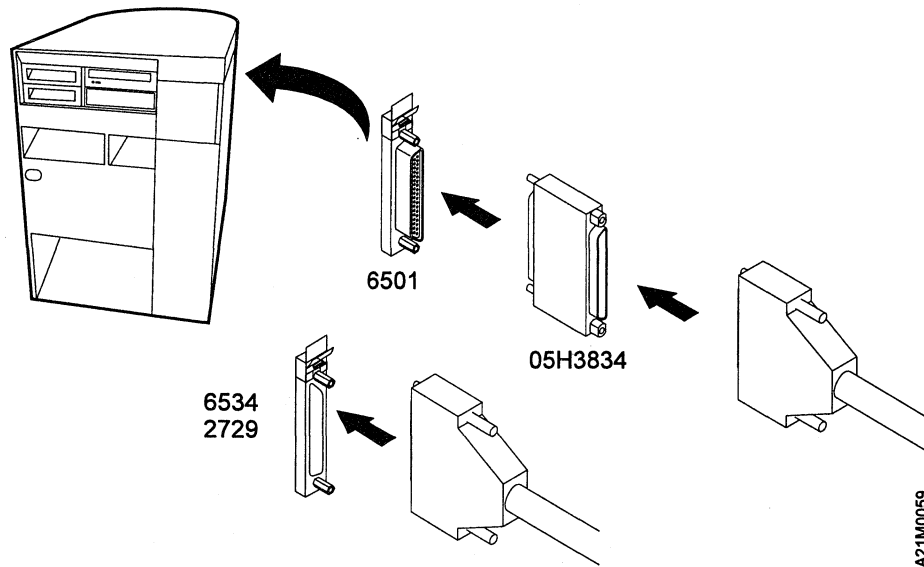

Figure 17. Installing the AS/400 SCSI System Cable at the Host Initiator

- 2. If the Magstar MP is the first or only SCSI device connected in line to the initiator, connect the SCSI interface cable coming from the initiator to the leftmost SCSI connector on the back of Model C00 (see Figure 18 and **3** in Figure 20).
- 3. If the Magstar MP is not the first device on the SCSI bus, connect the SCSI interface cable coming from the next closest device to the leftmost SCSI connector on the back of Model C00 (see Figure 19 and **3** in Figure 20).
- 4. If this is the last device on this SCSI bus, locate the SCSI interface terminator (P/N 61G8342) and attach it to the rightmost SCSI connector on the back of Model C00 (see Figure 18, Figure 19, and **2** in Figure 20).
- 5. If Model C00 is not the last device on this SCSI bus, locate the SCSI interface cable to the next device and connect it to the unused, rightmost SCSI interface connector on the back of Model C00 (see Figure 19 and **2** in Figure 20).

**Note:** There are two SCSI connectors on the back of Model C00. When they are connected correctly, each of these connectors must have either a SCSI interface cable or a SCSI terminator attached.

Figure 18 shows an example of a single Magstar MP attached to the host (initiator) and Figure 19 shows an example of attaching multiple SCSI devices to the host.

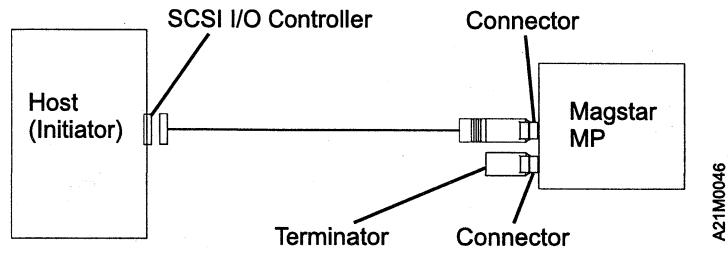

Figure 18. Example of Attaching One SCSI Device to the Host (Initiator)

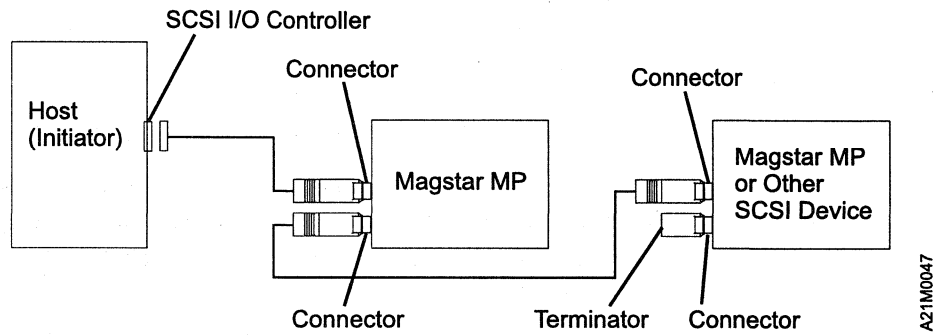

Figure 19. Example of Attaching Multiple SCSI Devices to the Host

Figure 20 shows the SCSI connectors for Model C00.

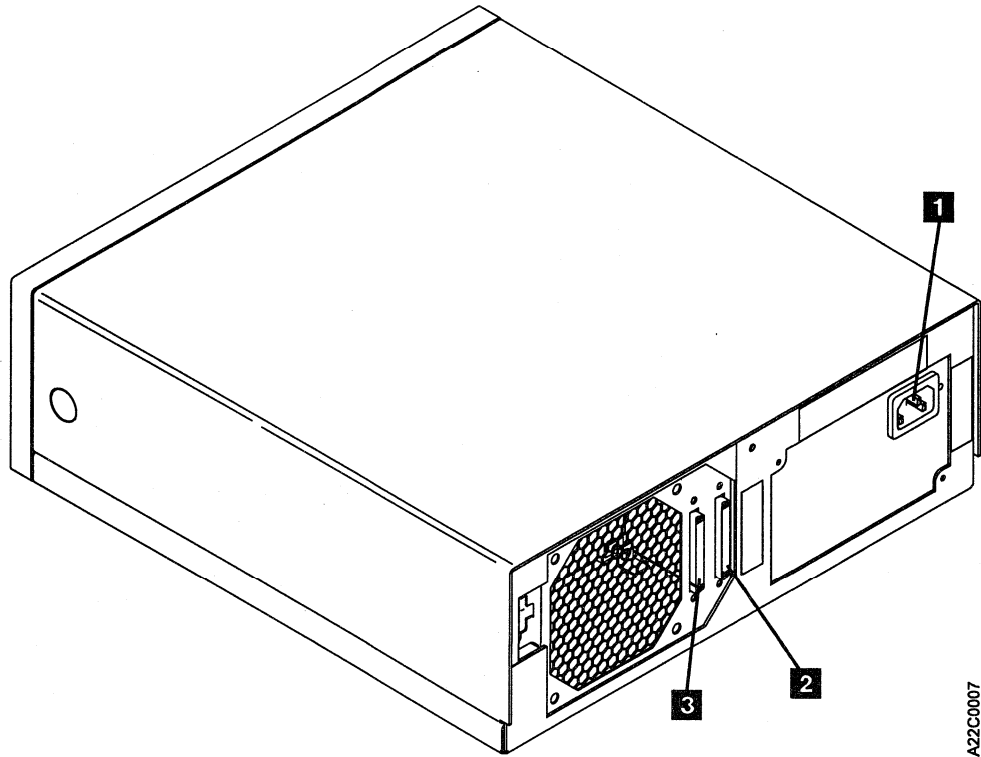

Figure 20. Rear View of Model C00

**1** Power cord connection.

**2** Rightmost SCSI device port for additional SCSI devices or, if none, a SCSI terminator.

**3** Leftmost SCSI device port for SCSI cable connection to the initiator.

— **6.** Ensure that the power cord **1** is connected to the drive unit and to the power source outlet that you have selected.

— **7.** Place the Power switch to the On position.

**Note:** If the Maintenance Indicator LED comes on solid, or if the maintenance, busy, and clean indicators all flash at the same time for 5 minutes, power off the drive and make the following checks:

- Verify the SCSI address.
- Ensure the terminator is in place.
- Check the SCSI cables for a solid connection.

After these checks are completed, power on the drive. If the problem is not fixed, call for service. Do not continue with the installation.



8. The initiator device drivers must be loaded to communicate with Model C00. When this has been done, Model C00 is ready for use. For attachment in RISC System/6000, Sun, HP-UX, Windows NT, or other Open System environments see *IBM SCSI Tape Drive, Medium Changer, and Library Device Drivers Installation and User's Guide, GC35-0154* for instructions to install and configure the device driver. Tape device drivers are supplied for attachment to these systems. The AS/400 system has a tape device driver supplied as part of the operating system.

To install the device driver and configure the device with **default** parameters, use the following procedures:

**For RISC System/6000:**

For additional information see *IBM SCSI Tape Drive, Medium Changer, and Library Device Drivers Installation and User's Guide, GC35-0154*.

- Performing the Default AIX Installation

Use the *installp* utility for installation. The software is always committed after installation. Insert the Tape Device Driver/AIX Enhanced diskette into the diskette drive on the workstation.

**Note:** You must have *root* authority to perform the commands in this section.

To install the device driver, enter the following command from the command line:

```
installp -acXd /dev/rfd0 Atape.driver
```

If the same version of *Atape.driver* is installed, then use the *installp* command with the *-F* flag to force an installation. The installation procedure automatically deconfigures any devices from the device driver and reconfigures them after the new driver is installed.

Enter the following command to list the currently installed version of *Atape.driver*:

```
lsipp -l Atape.driver
```

- Configuring the Magstar MP

After the driver software is installed and a Magstar MP is connected to the adapter card, the Magstar MP can be configured and made available for use. Access to the Magstar MP is not provided until the Magstar MP is configured.

Configure a Magstar MP 3570 Tape Subsystem by using **one** of the following procedures:

- a. Enter the following command with no parameters:

```
cfgmgr
```

The command automatically configures all devices known to the *Atape.driver*, including any new Magstar MP devices.

- b. Enter the following command to verify that the configuration completed successfully:

```
lsdev -Cc tape
```

**For AS/400:**

Ensure the AS/400 System value for Auto Configure Devices is set to **ON** and that all required PTFs are installed.

Turn the power on. If the Magstar MP is not recognized by the host (initiator), confirm the required PTFs are installed and re-IPL the AS/400 IOP card to which the Magstar MP is attached. If the problem is not resolved, call for service.

**For other systems:**

For other system attachments see *IBM SCSI Tape Drive, Medium Changer, and Library Device Drivers Installation and User's Guide*, GC35-0154 for instructions to install and configure the device driver.

- 9. To ensure that the read/write functions are performing properly, load and unload a cartridge. If this operation cannot be performed satisfactorily, see “LED Indicator Combinations” on page 30 and “Removing a Stuck Cartridge” on page 32. If following the steps in these two sections does not fix the problem, call for service.

The advanced user can refer to the following sections of the Magstar MP Maintenance Information to verify from the initiator that the read and write functions are performing properly:

**For RISC System/6000:**

“Checking the SCSI Attachment in an AIX Environment”

**For AS/400:**

“Checking the SCSI Attachment in an AS/400 Environment”

**For Sun:**

“Checking the SCSI Attachment in a Sun Environment”

**For HP-UX:**

“Checking the SCSI Attachment in an HP-UX Environment”

**For Windows NT:**

“Checking the SCSI Attachment in a Windows NT Environment”

## Removing or Relocating Model C00

If an installed Magstar MP Model C00 subsystem must be either disconnected or relocated to a different system, perform the following steps in the order shown:

- \_\_\_ 1. If your initiator has software aids for system upgrades, installations, or relocations, execute that software and follow the instructions provided with the software.
- \_\_\_ 2. Ensure that the tape cartridge has been removed from the drive.
- \_\_\_ 3. Notify the system operator that you must switch off power to Magstar MP Model C00 and that it will not be available.
- \_\_\_ 4. Set the Power switch to the Off position.



- \_\_\_ 5. Disconnect the ac power cord from the ac power source.
- \_\_\_ 6. Disconnect the ac power cord from Magstar MP Model C00.
- \_\_\_ 7. Disconnect the interface cables from Magstar MP Model C00.
- \_\_\_ 8. To protect the drive loader mechanism during shipping, the loader should be moved manually to the loaded position.
  - a. See Figure 21. Remove front cover of the unit **2** by depressing the tabs **1** on each side of the enclosure and carefully pulling the front cover away from the subsystem.

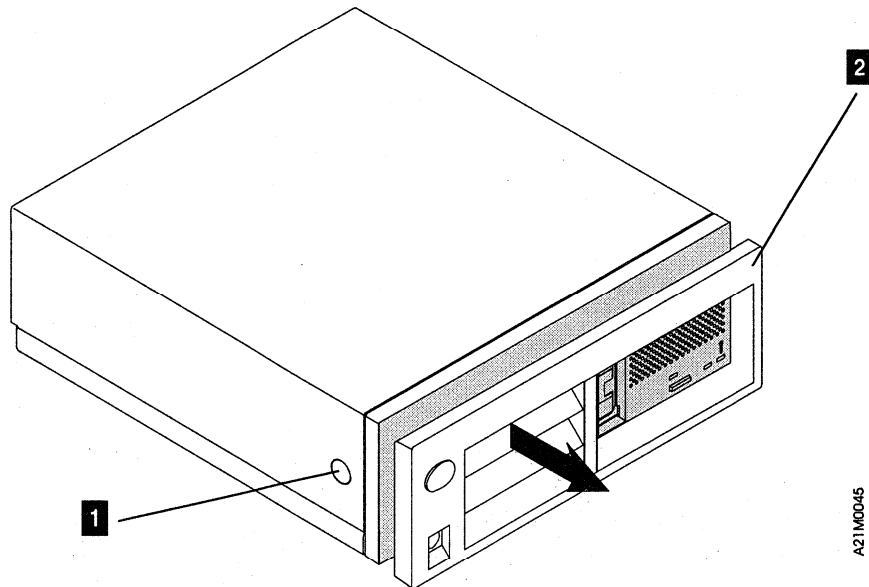

Figure 21. Removing the Front Cover from Model B00

**Note:** There is a corresponding tab on the opposite side of the chassis to the one shown as **1** in Figure 21.

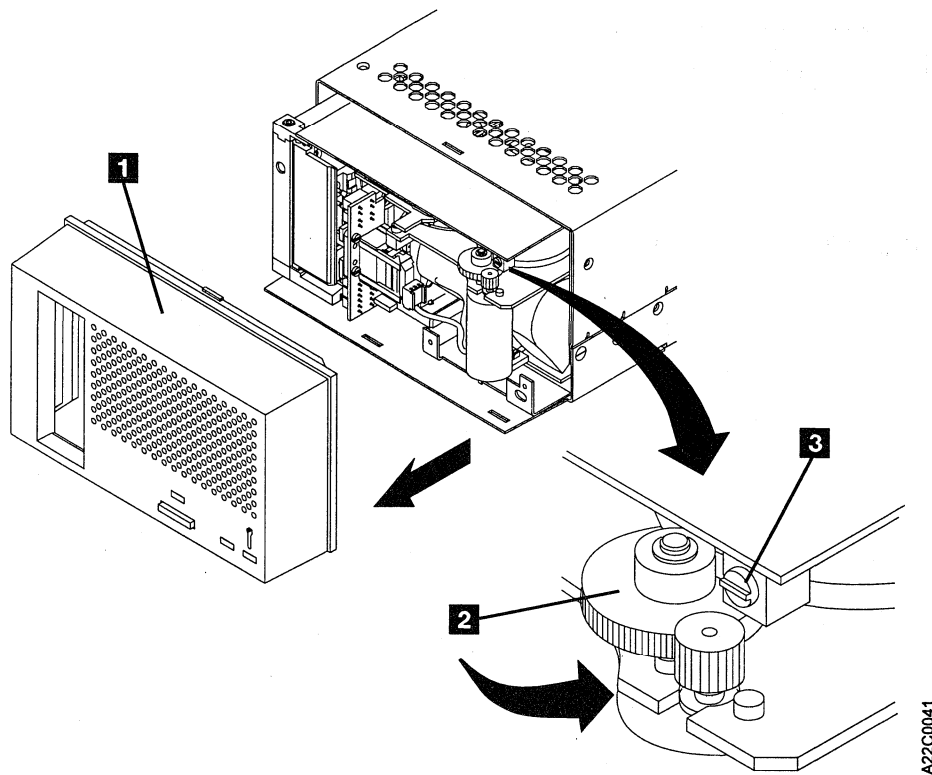

Figure 22. Positioning the Drive Loader for Shipping

- b. See Figure 22. Remove the drive cover **1** from the drive by pressing the top center of the drive cover and pulling it free.
  - c. Rotate the drive gear **2** (located near the rotary SCSI address switch **3**) to the right until the cartridge loader moves into the drive.
  - d. Replace the drive cover securely onto the front of the drive. Tilt the top of the drive cover forward to engage the top catch first. Then swing the drive cover downward and snap it into place.
  - e. Replace the front cover on the unit. Be sure to observe the detents on the chassis front as the front cover tabs are engaged with the enclosure.
- **9.** Move Magstar MP Model C00 to its new location, **or**
- **10.** If you are not re-installing Magstar MP Model C00, place the unit in its shipping box.

## Chapter 5. Operating the Model C00

This section describes the operator interface and control for Model C00.

### Drive Indicators and Operator Controls

Model C00 has an operator panel that contains one button and three LEDs located in the lower right hand corner of the drive when the unit is in the horizontal position. This panel (shown in Figure 23) is the interface for all operator functions.

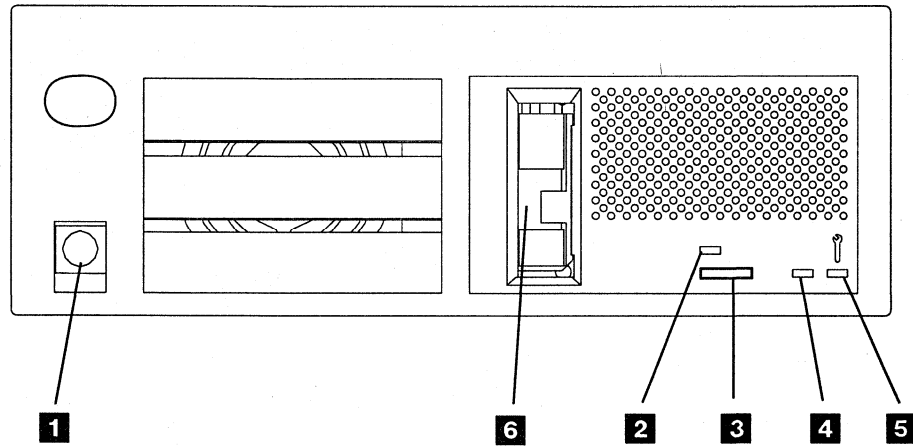

Figure 23. Model C00 Operator Panel

#### 1 Power On/Off Switch

This switch is connected to the dc power supply by a cable. The switch removes dc power from the output of the power supply.



**Note:** With the switch in the Off position, ac voltage is still available inside the device power supply.

#### 2 Tape Busy LED Indicator

This green LED indicates tape motion and will turn on solid when tape is in motion for reading, writing, locating, loading or cleaning. This indicator flashes when the operator presses the Unload button to rewind and unload tape, or when the device receives an Unload command on the SCSI interface. The indicator continues to flash until the device completes the rewind/unload operation.

#### 3 Tape Unload Button

This push button allows the operator to unload a cartridge from the drive. The Busy indicator flashes while the tape is rewinding and unloading.

#### **4** Clean LED Indicator

This yellow LED indicates that cleaning is required. When cleaning is required, the indicator will flash while the Busy and Maintenance indicators are off. This indicator prompts the operator to insert a cleaning cartridge to clean the tape head. If the clean LED is on solid and both the Busy and Maintenance LEDs are off, the drive is disabled until it has been cleaned. See "Cleaning the Tape Path" on page 34.

#### **5** Maintenance LED Indicator

The rightmost LED is a yellow indicator that the device needs service or is running diagnostics. This indicator along with the Clean and Busy LEDs will flash in selected patterns when the device detects a problem that requires a service call.

This LED will remain on for a short time during power-on reset as a lamp test and then changes to flashing until the power-on self-tests have completed. If, during a power-on sequence, this LED does not flash or flashes with the other two LEDs, the device needs service. This LED flashes any time the device is busy running diagnostic tests.

#### **6** Drive Door

This door is where a cartridge is loaded into Model C00.

---

## LED Indicator Combinations

Model C00 uses three LEDs on the operator panel in various combinations (as shown in Figure 24) to indicate operator messages and error conditions.

<i>Figure 24. Operator Actions</i>			
Busy <b>2</b>	Clean <b>4</b>	Maintenance <b>5</b>	Action (see Figure 23 on page 29)
On	On	Off	Unload the cartridge. If it does not unload properly, see "Removing a Stuck Cartridge" on page 32. Check the cartridge for damage.
On	On	On	Normal operation.
Flashing	Flashing	Flashing	See note. Turn power off and then on. If the condition persists, call for service.
Flashing	Flashing	On	Call for service.
Off	On	Off	The drive has been disabled until it is cleaned.
<b>Note:</b> All three indicators flash quickly, then all three come on solid for a time, and then the three indicators flash quickly again. This pattern may repeat to indicate that the microcode has encountered problems and is trying to recover. If the microcode fails to recover, it will flash the three indicators continuously until the device is powered off or reset. If this procedure does not fix the problem, call for service.			

## Ready Indicator

There is no indicator on Model C00 to indicate when a cartridge is loaded and ready for reading and writing. As a cartridge is loaded in the drive, the BUSY indicator will momentarily light while the drive is locating to the loadpoint on the tape. The drive is ready for reading and writing when the indicator goes out after loading the tape.

---

## Loading a Cartridge

A cartridge is loaded into Model C00 by placing the slanted end against the drive door (see **6** in Figure 23) with the longest edge on top and gently pushing it into the drive with a fingertip. Do not use force. When it is properly aligned inside the drive door, the cartridge will be gripped by the loader and taken inside the drive.

---

## Unloading a Cartridge

Press the Tape Unload button (see **3** in Figure 23) on the Model C00 operator panel to unload a cartridge from the drive. The Busy indicator flashes while the tape is rewinding and unloading.

In some circumstances, when certain error conditions exist, the Unload button will not work. If this happens, power off the Magstar MP and then turn the power on. The drive should automatically unload the cartridge. If it does not unload, see "Removing a Stuck Cartridge" on page 32.

---

## Unload/Load Maintenance Cycle

To maximize data reliability, the drive may unload a data cartridge and automatically reload it. This maintenance cycle allows a built-in drive cleaning operation to take place. The entire operation takes less than one second to complete. The operator should not interfere with this routine process.

## Removing a Stuck Cartridge

If a cartridge does not unload when requested, turn the Power switch off and then on again. In most cases, this method will solve the problem and the cartridge will eject normally.

**Note:** You will lose any error message information indicated by the LEDs when you power off. Before powering off the unit, write down the combination of which LEDs are on so you can give this information to your service representative if a service call becomes necessary. See Figure 24 on page 30 for indicator combinations.

In those infrequent cases when turning the power off and then on again does not work, perform the following steps in the order indicated (see Figure 25):

- 1. Be sure the Power switch for Model C00 is set to the Off position. The switch is off when it is in the out position and even with the surface of the drive cover.
- 2. Disconnect the power cord from the ac power source.



- 3. Remove the front cover of the unit **2** by depressing the tabs **1** on each side of the enclosure and carefully pulling the front cover away from the subsystem.

**Note:** There is a corresponding tab on the opposite side of the chassis to the one shown as **1** in Figure 25.

Be sure to observe the detents in the chassis as you pull away the front cover.

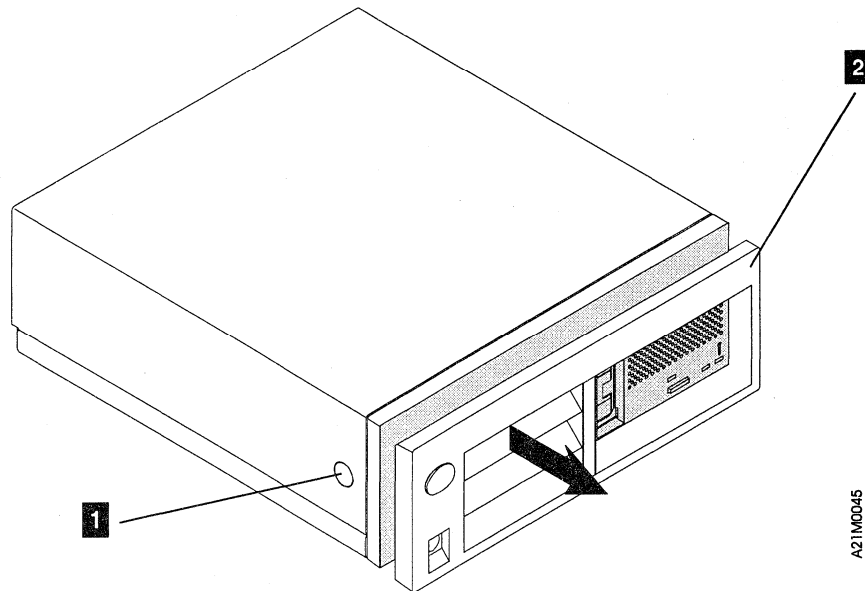

Figure 25. Removing the Front Cover from Model C00



- 4. See Figure 26. Remove the drive cover **3** from the drive by pressing the top center of the drive cover and pulling it free.
  - 5. Rotate the drive gear **1** (located near the rotary SCSI address switch **4**) to the left until the cartridge is freed and moves slightly out of the drive **2**. As you turn the gear, you will see that it is spring wound. Do not release tension on it with your finger as you rotate it or it will return to its original position.
- Note:** After the cartridge is freed, it will not be necessary to rotate the gear any further. After freeing the cartridge, the gear will reach a stop point where it will not turn any further. Do not attempt to force the gear past that point.
- 6. Pull the cartridge completely free of the unit.
  - 7. Replace the drive cover securely onto the front of the drive. Tilt the top of the drive cover forward to engage the top catch first. Then swing the drive cover downward and snap it into place.
  - 8. Replace the front cover on the unit. Be sure to observe the detents in the front of the chassis as the tabs on the front cover re-engaged with the enclosure.
  - 9. Plug the power cord back into the ac power source.
  - 10. Power on the unit and continue operation.

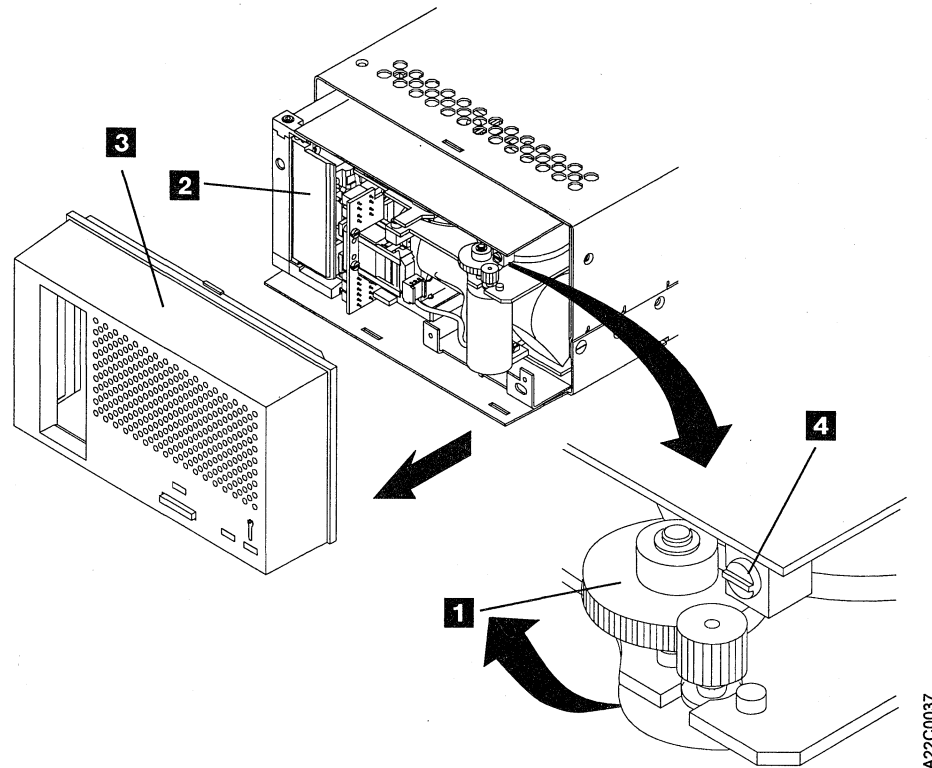

Figure 26. Removing a Stuck Cartridge from Model C00

---

## Cleaning the Tape Path

The tape path must be kept clean to prevent errors caused by contamination. A cleaning cartridge is shipped with each Model C00 for use only in a Magstar MP device. A cleaning cartridge is identified by the IBM Magstar MP Cleaning Cartridge label on its side.

The need for cleaning the tape head is determined within each unit by microcode. Model C00 has a yellow LED indicator (see **4** in Figure 23 on page 29) that flashes when cleaning is required. This prompts the operator to insert a cleaning cartridge into the drive. The cartridge is ejected automatically when cleaning is complete.

### Notes:

1. The cleaning cartridge should be replaced after 100 uses.
2. If the drive is not cleaned when indicated, and the cleaning indicator is repeatedly ignored, the drive may become disabled until it is cleaned. If the drive is disabled because the need for cleaning is ignored, the Clean LED will be On solid, and both the Busy and the Maintenance LEDs will be off. To enable the drive again, clean the drive by inserting a cleaning cartridge into the drive.

## Chapter 6. Quick Reference for the Library Models

This section describes some of the basic, common operations for the library models; It contains helpful hints for resolving problems on these models. It also lists the most common tasks performed by the operator of the Magstar MP 3570 Tape Subsystem and describes where to find information about each task. Helpful hints for operator-level troubleshooting are also included.

### How Do I...?

Figure 27 lists the most common tasks performed by the operator of the library models, and describes where to find information about each task.

<i>Figure 27 (Page 1 of 3). Quick Reference for Library Models</i>	
<b>How do I...</b>	<b>See...</b>
<b>Get started?</b>	Chapter 7, "Installing the Models C01 and C02" on page 41 and Chapter 8, "Customer Installed Rack-Mounted Models C21 and C22" on page 73.
<b>Choose a library mode of operation?</b>	"Library Modes of Operation" on page 115 and "Library Mode Selection" on page 131.
<b>Choose a library configuration?</b>	"Library Configurations" on page 117 and "Library Configuration Selection" on page 132.
<b>Pause the automatic loading of cartridges?</b>	"Pausing the Cartridge Sequence" on page 131.
<b>Reset the order that cartridges are processed in?</b>	"Resetting the Cartridge Sequence" on page 132.
<b>Load or unload a cartridge?</b>	"Cartridge Import and Export Positions" on page 124 and "Unloading or Loading a Cartridge in a Library Magazine" on page 128.
<b>Insert or remove a magazine?</b>	"Inserting or Removing a Magazine" on page 126.
<b>Write protect a cartridge?</b>	"Magstar MP Fast Access Linear Tape Cartridge" on page 5.
<b>Read the operator messages and menus?</b>	"Operator Panel Overview" on page 135 and "Status Screen" on page 137.
<b>Select an option from a menu?</b>	"Menu Screens" on page 143.
<b>Put a label on the cartridge?</b>	"Cartridge Label Replacement" on page 162.
<b>Tell a cleaning cartridge from a data cartridge?</b>	"Magstar MP Fast Access Linear Tape Cartridge" on page 5.
<b>Clean the drive tape path?</b>	"Cleaning the Drive Unit Tape Path" on page 129.
<b>Order additional media supplies?</b>	"If You Need Additional Media" on page 47.

<i>Figure 27 (Page 2 of 3). Quick Reference for Library Models</i>	
<b>Decide where to locate the library?</b>	"Subsystem Placement" on page 48.
<b>Select the language for the menus?</b>	"Setting the SCSI Address and Configuring the Library" on page 55.
<b>Set the SCSI address?</b>	"Setting the SCSI Address and Configuring the Library" on page 55.
<b>Connect the library to a host (initiator)?</b>	"Host (Initiator) Connection" on page 58.
<b>Move or relocate an installed library?</b>	"Removing or Relocating Models C01 or C02" on page 71 and "Removing or Relocating Models C21 and C22" on page 113.
<b>Read the front panel LEDs?</b>	"Front Panel Overview" on page 121.
<b>Remove a stuck cartridge?</b>	"Removing a Stuck Cartridge" on page 129.
<b>Store cartridges?</b>	"Storage Environment" on page 163.
<b>Safely dispose of cartridges?</b>	"Cartridge Degaussing and Disposal" on page 160.
<b>Check the library status?</b>	"Status Screen" on page 137.
<b>Continue when the drive status indicates RECOVER?</b>	"Clearing Tape Drive Recover Status" on page 133.
<b>Get notified of errors?</b>	"Intervention Screens" on page 141 and "Status Screen" on page 137.
<b>Go to a specific menu?</b>	"Operator Menus" on page 143.
<b>Insert or remove a cleaning cartridge?</b>	"Inserting or Removing a Cleaning Cartridge" on page 129.
<b>Tell drive 1 from drive 2?</b>	Drive 1 is on the right when viewed from the front of the unit. Drive 2 is on the left of the unit.
<b>Resolve Read/Write or Media Errors, or FID FE Errors?</b>	"Resolving Read/Write, Media, or FID FE Error" on page 133.
<b>Resolve Bar Code Reader Errors, or FID 94 Errors?</b>	"Resolving Bar Code Reader Problems" on page 133.
<b>Select a VOLSER?</b>	"Setting the Volume ID" on page 134.
<b>Correct a mismatch between the VOLSER and the Bar Code Label?</b>	"Resolving a Mismatch Between the Bar Code Label and VOLSER" on page 135
<b>Update microcode in the Magstar MP?</b>	"Updating Microcode from an AS/400" on page 154, "Updating Microcode from RS/6000 by Using TAPEUTIL" on page 154, "Updating Microcode from a Sun System" on page 157, "Updating Microcode from an HP-UX System" on page 157, or "Updating Microcode from a Windows NT System" on page 157.
<b>Replace lost keys?</b>	See step 14 on page 46.

Figure 27 (Page 3 of 3). Quick Reference for Library Models

<b>Check the SCSI Bus?</b>	Refer to the following sections in the Common Procedures chapter of the <i>IBM Magstar MP Tape Subsystem Maintenance Information</i> for more information.  Checking SCSI Attachment in AIX Environment  Checking SCSI Attachment in AS/400 Environment  Checking SCSI Attachment in HP Environment  Checking SCSI Attachment in SUN Environment  Checking SCSI Attachment in WIN/NT Environment
<b>Determine SCSI Bus Problems?</b>	Refer to the <i>IBM Magstar MP Tape Subsystem Maintenance Information</i> for more information.

## Helpful Hints for Resolving Problems

Many of the problems encountered in the use of the library models can be resolved readily by the operator without the assistance of a service representative. Many error messages have associated supplemental messages designed to help the operator fix a problem. After an error message appears, the operator need only press the Enter button to receive any available supplemental messages. See "Intervention Screens" on page 141 for a list of error messages and the recommended actions to follow to fix the problem.

Do the following simple steps first whenever normal operation is disrupted:

- Ensure that all cartridges are properly positioned in magazine cells or the drive.
- Try to unload the cartridge. If a cartridge is stuck in the drive, see "Removing a Stuck Cartridge" on page 129.
- Check the integrity of the cartridge to see that it is properly functioning and is not broken or otherwise obstructed by contaminants or improperly applied user labels.
- Check the display panel to see if a closed lock symbol is present. If it is, the cartridge is write protected and will not allow a write operation to take place.
- Check to see if the write-protect tab is set in the upward position to protect the tape from being written on. If you are attempting to write on the tape with the write-protect tab upward, you will experience an error condition.
- Check to ensure that the cartridge is the proper type (the Magstar MP Fast Access Linear Tape). For more information, see "Magstar MP Fast Access Linear Tape Cartridge" on page 5.
- If an Attention and Supplemental Message indicating DRIVE DISABLED UNTIL CLEANED is displayed, the tape drive must be cleaned before further use of the

drive is allowed. See “Resolving ATTENTION Messages” on page 142 for further information.

- If the operator panel indicates REPLACE CLN CART, the cleaning cartridge has been used up and needs to be replaced. See “If You Need Additional Media” on page 47 for cleaning cartridge ordering information and “Inserting or Removing a Cleaning Cartridge” on page 129 for the replacement procedure. Continue to use the old cleaning cartridge until you receive the new one.
- If the bar code reader feature is installed and host displays a message stating the VOLSER (Volume ID) does not match, or a cartridge not found message, see “Resolving Bar Code Reader Problems” on page 133.
- If the bar code reader cannot read a label on the tape cartridge, see “Resolving Bar Code Reader Problems” on page 133.
- Ensure that a cleaner cartridge has been inserted if one has been requested and, conversely, that no cleaner cartridge has been inserted if a data cartridge is required.
- Check to see if the display indicates FID1 95. If it does, you may have forgotten to remove the shipping bracket. Remove the bracket and continue the procedure. See 5 on page 50 under “Verifying Operability of the Library Unit” on page 49.
- Ensure the library menu is in operator mode (see **5** in Figure 85 on page 135).
- Check the host software settings to make sure that compression is not enabled.
- Two power cords are required for the dual-drive models (C02 and C12). Make sure both power cords are plugged into the library unit and into the power outlet.
- Turn the power off and then on again.

#### **ADSM Hints**

- When using ADSM with a dual-drive library, it is recommended the Magstar MP be configured to operate in Random Mode in Base Configuration. This allows ADSM to use the second drive for reclamation.

## **AS/400 Hints:**

PTFs (Program Temporary Fix) are required prior to attaching a Magstar MP 3570 Tape Subsystem to an AS/400 system. The PTFs for all supported AS/400 releases are listed in INFO APAR II10363. This info APAR contains the most current PTF information for all supported releases and important information concerning the attachment of the Magstar MP 3570 Tape Subsystem to the AS/400.

After installing the appropriate PTFs, a SAVSYS must be done to ensure the new IOP code is available during a system recovery.

The FC 2729 adapter shares a Combined Function IOP with the communications subsystems. Resetting the 2729 will disrupt the associated communications adapters.

Whenever possible, create the Magstar MP configuration by performing an IPL of the I/O processor after attaching it to the Magstar MP. Ensure the AS/400 system value for Autoconfigure Devices is set to on. The I/O processor may be IPLed by varying off and varying on with RESET or by using the System Service Tools (STRSST). Refer to the *Application System/400 Service Functions User's Guide* for information about the System Service Tools.

For Alt-IPL (D IPL) use Automatic or Manual Mode. Random mode can be used after XPF has been installed and the device configurations have been created or restored. When using BRMS/400, follow the recovery report.

When upgrading or installing a new release of OS/400, the 3570 must be in Auto or Manual mode.

Base and Split configurations are supported. When switching between Base and Split configuration, the I/O processor must be reloaded. To reload the I/O processor, vary off and vary on with reset or use STRSST to IP the I/O processor.

In Base configuration, each tape drive must be set to a different SCSI address.

### For Operating System/400 V3R1 and V3R2:

- The Magstar MP will be configured as TAPxx, where xx is the next tape device number.
- A library device must be manually created to operate in Random mode.
- The VFYTAP command must be run in MANUAL mode or AUTOMATIC mode. Inconsistent results happen when run in Random mode.

### For Operating System/400 V3R6 and V3R7:

- The Magstar MP configuration will consist of both a tape device (TAPxx), and a library device (TAPLIByy for V3R6; TAPMLByy for V3R7), where xx is the next tape device number and yy is the next library device.
- The system will configure with TAPLIByy or TAPMLByy as varied on.
  - To run with TAPLIByy or TAPMLByy configurations, Magstar MP must be in Random mode.
  - When not running in library mode, vary TAPLIByy or TAPMLByy off and vary TAPxx on.
  - **Never** have both TAPLIByy or TAPMLByy and TAPxx varied on at the same time.
- Run the VFYTAP command in MANUAL mode or AUTOMATIC mode.

### BRMS/400 Requirements

- For OS/400 releases V3R1 and V3R2, the library device must be placed in "hold" status when switching from Random mode to Automatic or Manual mode. Use the WRKDEVBRM command to hold/release the library device.





## Chapter 7. Installing the Models C01 and C02

This chapter describes the installation and connection of Models C01 and C02, as well as system placement and verification that the transport mechanism is functioning properly.

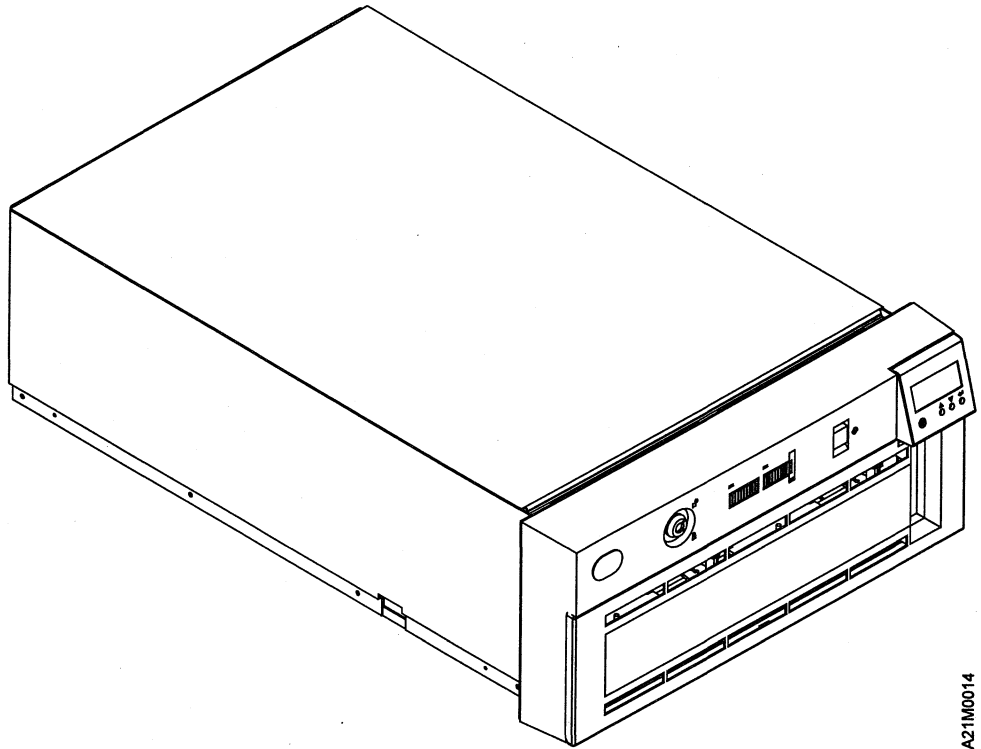

A21M0014

Figure 28. Models C01 and C02 (shown without external covers)

### Note:

- When removing the Magstar MP 3570 Tape Subsystem from the shipping container, do not hold on to the Operator Panel Display (see **1** in Figure 34 on page 49) when lifting the unit.
- IF YOU ARE INSTALLING Model C00, see Chapter 4, "Installing the Model C00" on page 13.
- The only library units that may be installed by the operator are models C01, C02, C21, and C22. If a service representative installs these models, it is a customer billable service call.
- Models C11 and C12, which are rack-mounted units, must be installed by a service representative.

---

## Before You Begin

Read "Safety Notices" on page xi.



### CAUTION:

**Model C01 weighs approximately 35 kilograms (77 pounds) and the Magstar MP Library Model C02 weighs approximately 40 kilograms (88 pounds). It takes three people to safely lift the unit.**

**Note:** A #2 Phillips screwdriver, a flat-blade screwdriver, and a 7-mm nut driver may be required for installation.

See your host (initiator) management or system hardware books to locate information that you will need to install the library unit. You may find the needed information under the following topics:

1. Installing an external SCSI tape drive
2. SCSI controllers
3. External SCSI devices

If the host system has any software or written instructions for system upgrades, use those instructions.

If there are no specific host system software aids or written instructions for system upgrades, use the following installation instructions. You may need to refer to your host system management or system hardware books to locate information you need to install the Magstar MP.

**Note:** The library unit must be positioned in horizontal orientation, with slots arrayed vertically, and the priority cell on the right.

### RS/6000 Note:

Check that the flash memory on the SCSI adapter in the system contains the proper level of microcode. Affected machine types include any system that contains a SCSI-2 Differential F/W adapter (4-6) or SCSI-2 Enhanced Differential F/W adapter (4-C).

To determine if your machine has an adapter with downlevel microcode, type this command on an AIX prompt: **lscfg -vl ascsi\* | pg**

To determine if you have a 4-6 or 4-C SCSI adapter, look at the lines labeled **Displayable Message** and **Loadable Microcode Level**.

The **4-6** adapter will indicate:

```
Displayable Message.....SCSI-2FWSD
Loadable Microcode Level.....0010
```

The **4-C** adapter will indicate:

```
Displayable Message.....SCSI-2FWSD
Loadable Microcode Level.....0080
```

Look for the line **ROS Level and ID** which should show as:

```
ROS Level and ID .....XX
```

- For the 4-6:

**XX** should be either 67, 68, 70, 72, 73, 74, or higher.

If 74 or higher is displayed, there is no need to apply any update to the 4-6.

- For the 4-C:

**XX** should be either C4, C5, C6, or higher.

If C6 or higher is displayed, there is no need to apply any update

Level 74 & C6 or higher microcode is strongly recommended for use with IBM Magstar MP tape drives, to ensure optimum performance and reduced errors. It may also resolve problems with other sequential SCSI devices (or devices that do not support command queuing) that are attached to dedicated F/W controllers and used in systems with multiple F/W adapters.

### AS/400 Hints

PTFs (Program Temporary Fix) are required prior to attaching a Magstar MP 3570 Tape Subsystem to an AS/400 system. The PTFs for all supported AS/400 releases are listed in INFO APAR II10363. This info APAR contains the most current PTF information for all supported releases and important information concerning the attachment of the Magstar MP 3570 Tape Subsystem to the AS/400.

After installing the appropriate PTFs, a SAVSYS must be done to ensure the new IOP code is available during a system recovery.

The Magstar MP also attaches to the following systems:

- Hewlett Packard: 900 Series 800, /T, and /K class servers running HP-UX 10.0X through 10.3X. Other servers that support HP Precision Bus (HP-PB) fast/wide (FW) Differential Adapter 28696A.
- Windows NT: Microsoft Windows NT Server version 4.0 with service pack 3 or greater. Intel processors require an Adaptec 2944 fast/wide SCSI adapter, Symbios Logic SYM8751D PCI SCSI Adapter, or equivalent.
- Sun Solaris: Solaris 2.3, 2.4, 2.51, and 2.6 for Sun and Sun Sparc. Requires SCSI-2 fast/wide differential adapter.

After identifying the location of the host SCSI controllers, where the SCSI cable connections are to be made, complete the following steps in the sequence shown and check off each step as it is completed.

## Models C01 and C02 in Base Configuration

(See "Library Configurations" on page 117 for an explanation of Base Configurations.)

\_\_\_ 1. Record in which slot the SCSI controller is located on the back of the host (initiator) \_\_\_\_\_.

**Note:** If attaching the library to AS/400, only one library can be attached to a port. (There are two ports per type 6501 SCSI controller.)

\_\_\_ 2. Record the SCSI address to be used for tape drive 1 \_\_\_\_\_. (It is recommended that SCSI address 0 be used for connection to AS/400 systems if the drive is to be used as an IPL device.)

\_\_\_ 3. For installation of Model C02, record the SCSI address to be used for tape drive 2 \_\_\_\_\_. (The SCSI address for tape drive 2 must be different than the SCSI address used for tape drive 1.)

\_\_\_ 4. Determine the proper way to quiesce (vary offline) the SCSI ports on the hosts (initiators) to which the Magstar MP will be attached.

\_\_\_ 5. Continue with "Pre-installation Checklist" on page 45.

## Model C02 in Split Configuration

(See "Library Configurations" on page 117 for an explanation of Split Configurations.)

\_\_\_ 1. Record the location (slot) from the back of the host (initiator) into which the SCSI controller will attach to drive 1 \_\_\_\_\_.

**Note:** If attaching the library to an AS/400 system, only one library can be attached to a port. (There are two ports per type 6501 SCSI controller.)

\_\_\_ 2. Record the location (slot) from the back of the host (initiator) into which the SCSI controller will attach to drive 2 \_\_\_\_\_.

**Note:** If attaching the library to an AS/400 system, only one library can be attached to a port. (There are two ports per type 6501 SCSI controller.)

\_\_\_ 3. Record the SCSI address to be used for tape drive 1 \_\_\_\_\_. (It is recommended that SCSI address 0 be used for connection to AS/400 systems if the drive is to be used as an IPL device.)

- \_\_\_ 4. Record the SCSI address to be used for tape drive 2 \_\_\_\_\_. (It is recommended that SCSI address 0 be used for connection to AS/400 systems if the drive is to be used as an IPL device.)
- \_\_\_ 5. Determine the proper way to quiesce (vary offline) the SCSI ports on the hosts (initiators) to which the Magstar MP will be attached.
- \_\_\_ 6. Continue with "Pre-installation Checklist."

## Pre-installation Checklist

Remove the packaging material and save for reshipment or relocation. It may be helpful to remove the outer shipping carton before lifting the unit.

**Note:** When removing the Magstar MP 3570 Tape Subsystem from the shipping container, do not hold on to the Operator Panel Display (see **1** in Figure 79 on page 121) when lifting the unit.

Check to ensure that you received the following items:

- \_\_\_ 1. Appropriate power cord(s) (see Figure 29)

**Note:** Two power cords are required for Model C02.

<i>Figure 29. Available Power Cords for Magstar MP 3570 Tape Subsystem</i>	
Magstar MP P/N and Feature Code	Description
46F5893 (FC 9080 and FC9986)	Watertight Plug / Power Cord, Chicago
46F5894 (FC 9080 and FC9800)	Watertight Plug / Power Cord, U.S.A.
6952300 (FC 9800)	9-ft Power Cord, 125V, 10A U.S.A./Canada
13F9979 (FC 9820)	2.7-m Power Cord, 250V, 10A France
13F9997 (FC 9821)	2.7-m Power Cord, 250V, 10A Denmark
14F0033 (FC 9825)	2.7-m Power Cord, 250V, 10A U.K.
14F0087 (FC 9827)	2.7-m Power Cord, 250V, 10A Israel
14F0051 (FC 9828)	2.7-m Power Cord, 250V, 10A Switzerland
14F0015 (FC 9829)	2.7-m Power Cord, 250V, 10A South Africa
14F0069 (FC 9830)	2.7-m Power Cord, 250V, 10A Italy
13F9940 (FC 9831)	2.7-m Power Cord, 250V, 10A Australia
1838574 (FC 9833)	9-ft Power Cord, 250V, 10A U.S.A./Canada
6952301 (FC 9986)	6-ft Power Cord, 125V, 10A Chicago

- \_\_\_ 2. One or more interposer(s) (if required) for attachment to the host (see Figure 30)

<i>Figure 30 (Page 1 of 2). RISC System/6000 and AS/400 Interposers</i>		
Host	Host Connection	Magstar MP Interposer P/N and Feature Code
RS/6000	PCI SCSI-2 Differential Fast/Wide Adapter (FC2409, identifier 4-B)	None required
RS/6000	PCI SCSI-2 Fast/Wide Differential Adapter (FC6207, identifier 4-L)	None required
RS/6000	PCI SCSI-2 Fast/Wide Differential Adapter (FC6209, identifier 4-B)	None required
RS/6000	SCSI-2 Differential Fast/Wide Adapter/A (FC2416, identifier 4-6)	50G0460 (FC 2892)

Host	Host Connection	Magstar MP Interposer P/N and Feature Code
RS/6000	Enhanced SCSI-2 Differential Fast/Wide Adapter/A (FC 2412, identifier 4-C)	50G0460 (FC 2892)
RS/6000	SCSI-2 Differential Fast/Narrow High-Performance External I/O Controller (FC 2420, identifier 4-2)	61G8323 (FC 2891)
AS/400	Magnetic Media Subsystem Controller (FC 2729)	None required
AS/400	Magnetic Media Subsystem Controller (FC 6501)	05H3834 (FC 2895)
AS/400	Magnetic Media Subsystem Controller (FC 6534)	None required

- \_\_\_ 3. One cleaning cartridge (P/N 05H2463)
- \_\_\_ 4. One or more cartridge magazines (P/N 49G6598)
- \_\_\_ 5. One or more Magstar MP Fast Access Linear Tape cartridges (P/N 08L6187)
- \_\_\_ 6. One Magstar MP device driver diskette for the RS/6000, Sun, HP-UX, Windows NT, or Open System attach feature

**Note:** A device driver diskette is not needed for AS/400 systems.

- \_\_\_ 7. Two pedestals and attaching screws
- \_\_\_ 8. One or more appropriate SCSI-2 cables (see Figure 31)

Magstar MP P/N and Feature Code	Description
P/N 49G6456 (FC 5205)	0.5-m (2-ft) SCSI Cable
P/N 49G6458 (FC 5212)	12-m (39-ft) SCSI Cable
P/N 49G6459 (FC 5218)	18-m (59-ft) SCSI Cable
P/N 49G6457 (FC 5245)	4.5-m (15-ft) SCSI Cable
P/N 08L6201 (FC 5225)	25.0-m (81-ft) SCSI Cable

- \_\_\_ 9. One SCSI terminator (P/N 61G8324) if the Magstar MP model is C01. Two SCSI terminators are provided with Model C02.
- \_\_\_ 10. One SCSI Bus Jumper (P/N 49G6456) is provided for Model C02 only.
- \_\_\_ 11. *IBM Magstar MP 3570 Tape Subsystem Operator Guide C-Series Models*
- \_\_\_ 12. *Magstar MP 3570 Tape Subsystem Maintenance Information, C-Series Models*
- \_\_\_ 13. *IBM SCSI Tape Drive, Medium Changer, and Library Device Drivers Installation and User's Guide, GC35-0154.*
- \_\_\_ 14. Library Door Keys (not included with Model C00). The keys are taped to the rear of the unit. Record the 5-digit number from the tag key here \_\_\_\_\_ . If the keys are lost or need to be replaced, additional keys can be ordered from.

Attention - IBM Account Manager  
Fort Lock Corp.  
3000 North River Road  
River Grove, IL 60171  
708-456-1100  
708-456-9476 FAX

**Note:** Specify Vendor P/N - G010103AX-3228 (C1038AD "Short" with IBM Logo) along with the 5-digit code that came with the original keys.

## If You Need Additional Media

Figure 32 shows additional supply items available from IBM Supply Fulfillment Operations.

<b>Part Number</b>	<b>Description</b>
05H2463	Cleaner Cartridge
49G6598	Cartridge Magazine
05H2462	B-Format Data Cartridge
08L6187	C-Format Data Cartridge
05H9393	B-Format Replacement Label Kit - 10 Sets of Labels
08L6191	C-Format Replacement Label Kit - 10 Sets of Labels

For additional Magstar MP cartridges, cleaning cartridges, labels, and magazines, contact the appropriate distributor for your location as given in Figure 33.

<b>Location</b>	<b>Contact</b>	<b>Telephone Number</b>
United States, Canada, Puerto Rico	IBM Media Distribution North America	888-IBM-MEDIA
Central America	General Business Machines	+1-305-539-3470
Spain	IBM Supplies Distribution Europe	900 983131
Italy	IBM Supplies Distribution Europe	1678 78349
France	IBM Supplies Distribution Europe	0590 5871
Germany	IBM Supplies Distribution Europe	0130 818 005
Sweden	IBM Supplies Distribution Europe	0207 94270
Norway	IBM Supplies Distribution Europe	800 11389
Denmark	IBM Supplies Distribution Europe	800 15534
Finland	IBM Supplies Distribution Europe	08001 13110
United Kingdom	IBM Supplies Distribution Europe	0800 968679
Elsewhere in Europe, Middle East, and Africa	IBM Supplies Distribution Europe	+31 433 502 756 (voice) +31 433 262 292 (fax)
Japan	Supply Services, IBM Japan, Ltd.	03-3546-7611

---

## Attaching the Pedestal



### CAUTION:

**Model C01 weighs approximately 35 kilograms (77 pounds) and the Magstar MP Library Model C02 weighs approximately 40 kilograms (88 pounds). It takes three people to safely lift the unit.**

Place the unit upside down on a non-scratch surface, and attach the two pedestals to the bottom of Models C01 or C02 by using the four screws provided.

---

## Subsystem Placement

Models C01 and C02 can be located anywhere (subject to the following restrictions):

1. The power cord(s) and the SCSI cable(s) must be the appropriate length (see Figure 37 on page 58).
2. The library unit should not be placed in a dusty location.
3. Do not stack more than one Magstar MP 3570 Tape Subsystem unit on top of another.
4. The library unit must be positioned in horizontal orientation, with slots arrayed vertically, and the priority cell on the right.

**Note:** Models C11 and C12 are rack-mounted units. Contact your service representative for installation.



## Verifying Operability of the Library Unit

Figure 34 shows the front assembly for Models C01 and C02. Perform the following steps in the order listed to ensure that the library transport mechanism is operating properly:

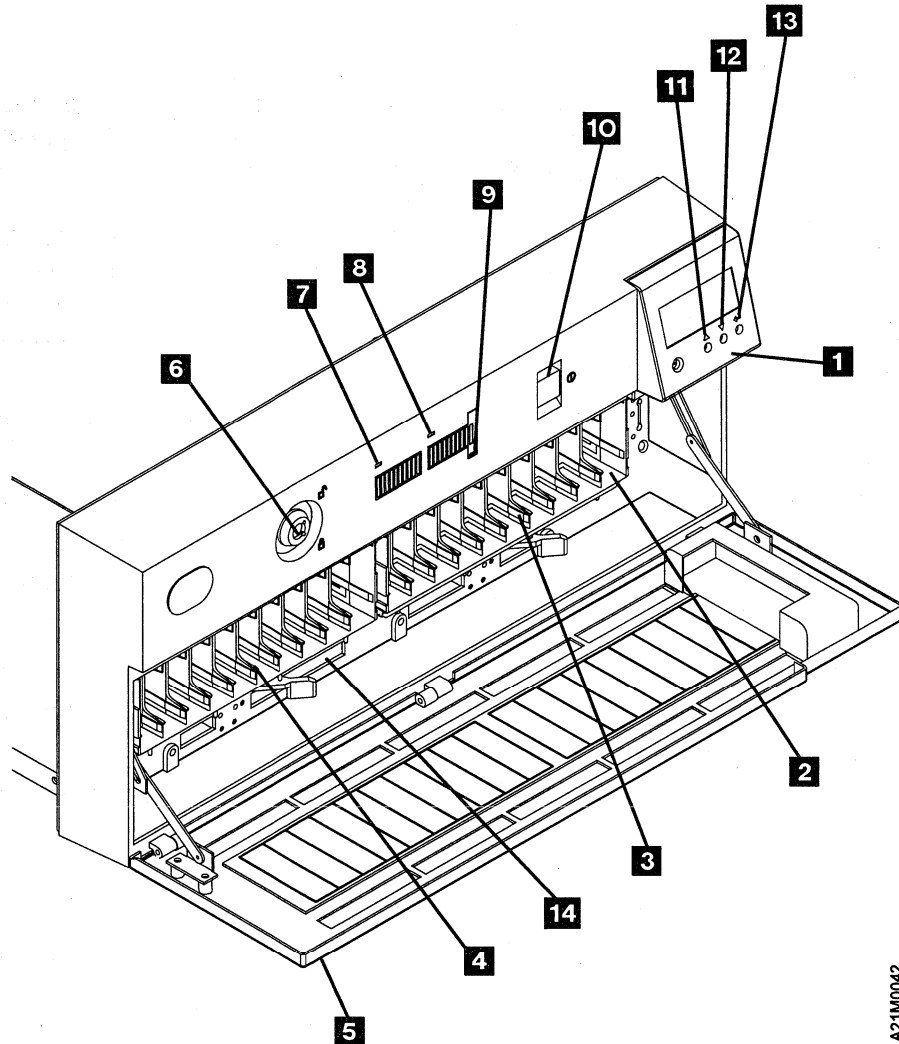

A21M0042

Figure 34. Front Assembly for Library Models.

- |                                      |  |
|--------------------------------------|--|
| <b>1</b> Operator Panel              | <b>8</b> Magazine 1 In Use Indicator                   |
| <b>2</b> Priority Cell               | <b>9</b> Priority Cell In Use Indicator                |
| <b>3</b> Magazine 1 Location         | <b>10</b> Power On/Off Switch                          |
| <b>4</b> Magazine 2 Location         | <b>11</b> ScrollUp                                     |
| <b>5</b> Door                        | <b>12</b> Scroll Down                                  |
| <b>6</b> Security Key Lock           | <b>13</b> Enter  |
| <b>7</b> Magazine 2 In Use Indicator | <b>14</b> Serial Number Location (above lever opening) |

1. Ensure that the Power switch **10** is set to the Off position. The switch is off when it is in the out position and even with the front cover surface.
2. Remove the rear cover plate by turning the two white hold-down fasteners on each side of the plate one-quarter turn in either direction to release them. Set the rear cover plate aside.

- 3. Unlock the library door **5** if it is locked (the keys are taped to the rear of the unit; refer to step 14 on page 46). See **6** for the lock location.
- 4. Open the library door **5** by pressing the raised ribs on the top center of the door.
- 5. Before turning on power, the orange stopper (see **1** in Figure 35) must be removed from the unit. The stopper is pressed on the rail to prevent the picker from moving during shipping. Do the following to remove the stopper:
  - a. Open the door and remove the tape from the magazine lock levers.
  - b. Look inside the unit and find the orange tag (see **2** in Figure 35) that is attached to the stopper. The orange tag will assist you in finding the orange stopper.
  - c. **Do not pull on the string or the tag to remove the stopper.** Reach inside the unit and pull the orange stopper off the rail using your finger.
  - d. Save the stopper with the packaging material for later reshipment or relocation.

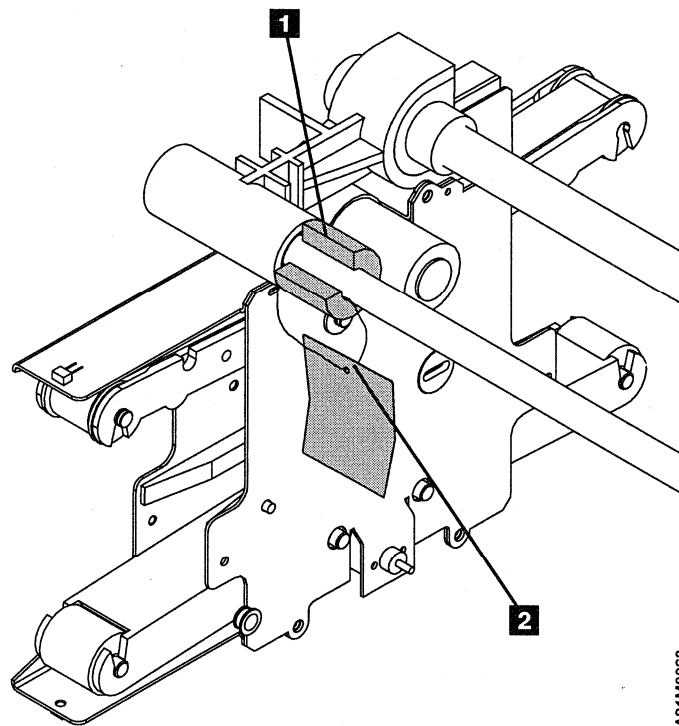

Figure 35. Orange Picker Stopper

- 6. Install the magazines (see “Inserting or Removing a Magazine” on page 126).
- 7. Close the door.

- \_\_\_ 8. Connect the power cord(s) to the library.



**Note:** Two power cords are required for Model C02.

- \_\_\_ 9. Connect the power cord(s) to the power source outlet. Ensure the cord(s) are plugged firmly into both the Magstar MP and the outlet, and that the outlet has the correct voltage.

- \_\_\_ 10. Press the Power switch **10** to the On position.

- \_\_\_ 11. Monitor the LED indicators **7**, **8**, and **9**.

They will remain flashing until the power-on self-test is completed, and then they will shut off. This power-on self-test lasts about 2.5 minutes. If the power-on self-test diagnostics detect a problem, a FRU identifier (field-replaceable unit identifier or FID) is posted on the operator panel. If an error occurs, you may be able to correct the error. See "Resolving ATTENTION Messages" on page 142 for specific actions to take. If you are unable to correct the error, note the FID and contact your service representative. Wait until the LED indicators are off before proceeding.

**Note:** If you forgot to remove the orange stopper, a FID1 95 notice will be posted. This is easily cleared by removing the orange stopper.

- \_\_\_ 12. If verifying the operation of Magstar MP Model C02, skip to step 20 on page 52.

### Model C01

- \_\_\_ 13. At power on, the Status screen will be displayed, press the Enter button **13** to display the Options Menu.

- \_\_\_ 14. See Figure 34 on page 49. Select SET LIBR MODE from the Options Menu by using the Scroll Down button **12** and the Scroll Up button **11**. Move the arrow (>) to the selection then press the Enter button **13**.

**Note:** Use the Scroll buttons and the Enter button in a similar manner whenever you select an option from a menu. It may be necessary to select CANCEL to return to the previous menu.

- \_\_\_ 15. Select manual mode of operation by performing the following steps at the operator panel:

a. Scroll Down, select MANUAL from the Set Library Mode Menu and press the Enter button. This selection will return you to the Options Menu.

b. Select SHOW STATUS to display the mode of operation.

At this point, the operator panel will display **M** at the start of line 2.

- \_\_\_ 16. Load a scratch cartridge through the priority cell (see **1** in Figure 36 on page 52) to the import position by pushing it gently into the priority cell until it comes to a stop and even with the front of the magazine. Select START from the main Options Menu.

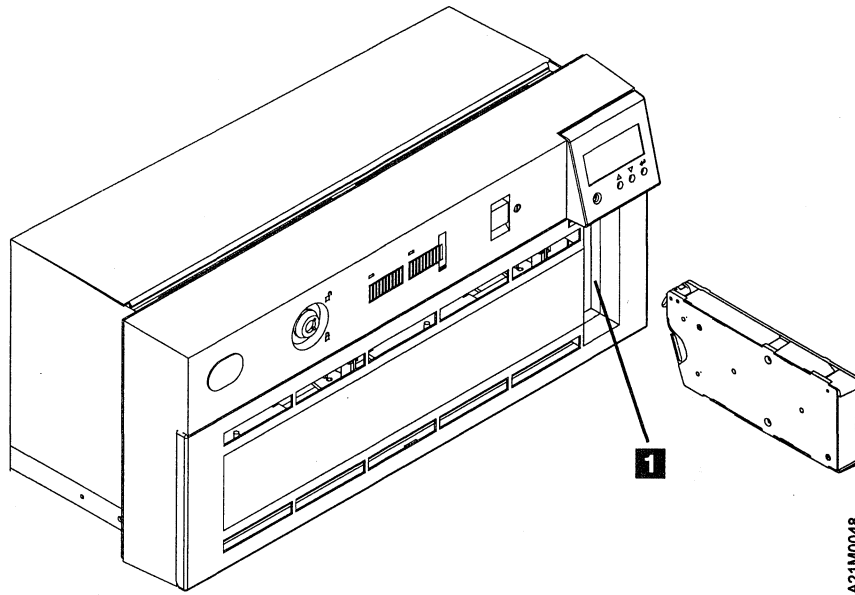

Figure 36. Location of Priority Cell in Library Models

- \_\_\_ 17. Verify the library is operating properly by observing the LOAD PT message on line 1 of the display. See “Resolving ATTENTION Messages” on page 142 if this message is not displayed.
- \_\_\_ 18. Select UNLOAD DRIVE from the Options Menu and ensure the cartridge comes out of the priority cell. See “Removing a Stuck Cartridge” on page 129 if the cartridge does not unload properly.
- \_\_\_ 19. Proceed to “Setting the SCSI Address and Configuring the Library” on page 55.

#### Model C02

- \_\_\_ 20. The library configuration of BAS or SPL is displayed on line 3 of the operator panel display. (Refer to item 16 in Figure 86 on page 137.) If the operator panel indicates Split Configuration (SPL) on line 3 of the display, continue with step 33 on page 53; otherwise continue with the next step.
- \_\_\_ 21. Press the Enter button to display the Options Menu.
- \_\_\_ 22. Select EDIT CONFIG from the Options Menu by using the Scroll Down button 12 and the Scroll Up button 11; then move the arrow (>) to the selection and press the Enter button. See Figure 34 on page 49.
  - Note:** Use the Scroll buttons and the Enter button in a similar manner whenever you select an option from a menu. In many cases, you may need to select CANCEL to return to the previous menu.
- \_\_\_ 23. Select SET LIBR CONFIG from the Edit Configuration Menu and press Enter.
- \_\_\_ 24. Use the Scroll Down button to move the arrow to the line indicating SPLIT, and press Enter.
- \_\_\_ 25. After SPLIT configuration is chosen, select CANCEL and press the Enter button to return to the Edit Configuration Menu.

- \_\_\_ 26. Select CANCEL and press Enter again. The Unload and Reset Menu will appear.
- \_\_\_ 27. Determine whether there is a cartridge in the drive by looking at the display. Line 3 pertains to drive 1; line 4 pertains to drive 2:
  - If \*UNLOAD DRIVE is displayed, no cartridge is in the drive.
  - If UNLOAD DRIVE (without an asterisk) is displayed, a cartridge is in the drive.
- \_\_\_ 28. Select UNLOAD DRIVE and press Enter if a cartridge is loaded in drive 1 or drive 2; otherwise skip to step 31.
- \_\_\_ 29. The cartridge will be unloaded from the drive and the status screen will be displayed. Press Enter to return to the Unload and Reset Menu.
- \_\_\_ 30. Repeat step 29 until there are no cartridges loaded in drives 1 or 2.
- \_\_\_ 31. Select RESET DRIVE and press Enter, then select PROCEED and press Enter.
- \_\_\_ 32. The Magstar MP will reset, run power-on diagnostics, and check the magazine cells to determine if cartridges are present. The reset is complete when all movement in the library has stopped and the hourglass symbols for each of the magazine cells has been replaced with a solid block, an open block, or a dash. When the reset is complete, press Enter to return to the Options Menu.
- \_\_\_ 33. Press the Enter button to display the Options Menu.
- \_\_\_ 34. See Figure 34 on page 49. Select SET LIBR MODE from the Options Menu by using the Scroll Down button **12** and the Scroll Up button **11** to move the arrow (>) to the selection, then press the Enter button **13**.
- \_\_\_ 35. Move the arrow to point to DRIVE 1, and press Enter.
  - a. Scroll Down and select MANUAL. After pressing Enter, the Drive Selection Menu is displayed.
- \_\_\_ 36. Move the arrow to point to DRIVE 2, and press Enter.
  - a. Scroll Down and select MANUAL. After pressing Enter, the Drive Selection Menu is displayed.
- \_\_\_ 37. Select CANCEL and press Enter to return to the Options Menu.
- \_\_\_ 38. Select SHOW STATUS to display the Status screen.
  - a. The operator panel should display M at the start of line 2, and M at the start of line 3, indicating Manual Mode for both tape drives.
- \_\_\_ 39. Press Enter to change from the Status screen to the Options Menu.
- \_\_\_ 40. Load a scratch cartridge through the priority cell (see Figure 36 on page 52) to the import position by pushing it gently into the priority cell until it comes to a stop, and even with the front of the magazine.
- \_\_\_ 41. Select START from the Options Menu and press Enter.
- \_\_\_ 42. Select DRIVE 1 from the Drive Selection Menu and press Enter.
- \_\_\_ 43. Verify the library is operating by observing the LOAD PT message on line 1 of the display. See "Resolving ATTENTION Messages" on page 142 if this message is not displayed.

- \_\_\_ **44.** Press Enter to change from the Status screen to the Options Menu.
- \_\_\_ **45.** Select UNLOAD DRIVE from the Options Menu and press Enter.
- \_\_\_ **46.** Select DRIVE 1 from the Drive Selection Menu and press Enter. Ensure the cartridge comes out of the priority cell. See “Removing a Stuck Cartridge” on page 129 if the cartridge does not unload properly.
- \_\_\_ **47.** Open the library door and load a scratch cartridge into any cell of magazine 2 (the leftmost magazine). Refer to “Unloading or Loading a Cartridge in a Library Magazine” on page 128 for the procedure.
- \_\_\_ **48.** When the library door has been closed, and all magazine cells have been checked for cartridges present, press Enter to change from the Status screen to the Options Menu.
- \_\_\_ **49.** Select START from the Options Menu and press Enter.
- \_\_\_ **50.** Select DRIVE 2 from the Drive Selection Menu and press Enter.
- \_\_\_ **51.** Verify the library is operating properly by observing the LOAD PT message on line 4 of the display. See “Resolving ATTENTION Messages” on page 142 if this message is not displayed.
- \_\_\_ **52.** Press Enter to change from the Status screen to the Options Menu.
- \_\_\_ **53.** Select UNLOAD DRIVE from the Options Menu and press Enter.
- \_\_\_ **54.** Select DRIVE 2 from the Drive Selection Menu and press Enter. Ensure the cartridge is unloaded into the magazine cell. See “Removing a Stuck Cartridge” on page 129 if the cartridge does not unload properly.
- \_\_\_ **55.** Remove the scratch cartridge from the cell in magazine 2. Refer to “Unloading or Loading a Cartridge in a Library Magazine” on page 128 for the procedure.
- \_\_\_ **56.** Proceed to “Setting the SCSI Address and Configuring the Library” on page 55.

---

## Setting the SCSI Address and Configuring the Library

The settings and configuration information selected in this procedure are saved in non-volatile memory and become the default settings after subsequent power-on cycles.

This section describes how to:

- Select the language used by the menus at step 2 of the following list.
- Load the cleaning cartridge as defined in step 3 below.
- Select the library configuration from the following list at step 4.
- Set the SCSI address(es) in step 8 for Model C02 and in step 10 on page 56 for Model C01.
- Select the library mode of operation at step 21 on page 56 for Model C02 and in step 34 on page 57 for Model C01.

Perform the following steps in the order indicated:

- \_\_\_ 1. At power on, the Status screen will be displayed. Press the Enter button to display the Options Menu.
- \_\_\_ 2. If a language for the menus other than English is desired, select SERVICES from the Options Menu and press Enter. Then select CHANGE LANG and press Enter. When the Change Language Menu appears, select English, Spanish, or German for the menus on the operator screen and press Enter.
- \_\_\_ 3. Select CLEAN from the Options Menu and press Enter. When the Clean Menu appears, select INSERT CLN TAPE and press Enter. If there is not a cleaning cartridge in the Priority Cell, a message will appear prompting the operator to PUT CLEANING CARTRIDGE IN PRIORITY CELL PRESS ENTER. After a cleaning cartridge is put in the Priority Cell and the Enter button is pressed, the cleaning cartridge will be loaded into the Magstar MP and stored in the internal cleaning cartridge storage cell. Select CANCEL and press Enter to return to the Options Menu.
- \_\_\_ 4. Select EDIT CONFIG from the Options Menu and press Enter.
- \_\_\_ 5. If a Magstar MP 3570 Tape Subsystem Model C01 is being installed, skip to step 10 on page 56.

### Model C02

- \_\_\_ 6. Select SET LIBR CONFIG from the Edit Configuration Menu and press Enter.
- \_\_\_ 7. An asterisk (\*) in front of BASE or SPLIT indicates the configuration that is currently selected. To keep the current configuration, select CANCEL and press Enter. To change the configuration, move the arrow to select the desired configuration (BASE or SPLIT) and press Enter; then Select CANCEL and press Enter to return to the Edit Configuration Menu. See "Library Configurations" on page 117 for an explanation of the configuration.
- \_\_\_ 8. Select ADDRESS DRV2 from the Edit Configuration Menu and press Enter.
- \_\_\_ 9. Select the SCSI address for tape drive 2 and press Enter; then Select CANCEL and press Enter to return to the Edit Configuration Menu.

**Note:** The SCSI address for tape drive 2 must be different than the SCSI address for tape drive 1, or problems may arise. Select the SCSI address previously recorded by following the instructions and checklist in “Before You Begin” on page 42.

### Models C01 and C02

- \_\_\_ 10. Select ADDRESS DRV1 from the Edit Configuration Menu and press Enter.
- \_\_\_ 11. Select the SCSI address for tape drive 1 and press Enter (for connection to AS/400, SCSI address 0 is recommended); then Select CANCEL and press Enter to return to the Edit Configuration Menu.

**Note:** Select the SCSI address previously recorded by following the instructions and checklist in “Before You Begin” on page 42.

- \_\_\_ 12. Select AUTO CLEAN from the Edit Configuration Menu and press Enter.
- \_\_\_ 13. An asterisk (\*) in front of ENABLE or DISABLE indicates if automatic cleaning is enabled or disabled. If the display shows \*ENABLE, the library unit will automatically clean the tape drive(s) when they require cleaning. If the display shows \*DISABLE, the operator must take action to clean the tape drive(s) when cleaning is required.

The default setting is automatic cleaning enabled. It is recommended to remain in this mode. To keep the current configuration, select CANCEL and press Enter. To change the configuration, move the arrow to select the desired configuration (ENABLE or DISABLE) and press Enter; then Select CANCEL and press Enter to return to the Edit Configuration Menu.

- \_\_\_ 14. Select CANCEL from the Edit Configuration Menu and press Enter.
- \_\_\_ 15. If a Magstar MP 3570 Tape Subsystem Model C01 is being installed, skip to step 31 on page 57.

### Model C02

- \_\_\_ 16. Determine whether there is a cartridge in the drive by looking at the display. Line 3 pertains to drive 1; line 4 pertains to drive 2:
  - If \*UNLOAD DRIVE is displayed, no cartridge is in the drive.
  - If UNLOAD DRIVE (without an asterisk) is displayed, a cartridge is in the drive.
- \_\_\_ 17. If a cartridge is loaded in drive 1 or drive 2, select UNLOAD DRIVE from the Unload and Reset Menu and press Enter; otherwise continue with step 20.
- \_\_\_ 18. The cartridge will be unloaded from the drive and the status screen will be displayed. Press Enter to return to the Unload and Reset Menu.
- \_\_\_ 19. Repeat step 18 until there are no cartridges loaded in drive 1 or drive 2.
- \_\_\_ 20. Select RESET DRIVE and press Enter, then select PROCEED and press Enter.
- \_\_\_ 21. The Magstar MP will reset, run power-on diagnostics, and check the magazine cells to determine if cartridges are present. The reset is complete when all movement in the library has stopped and the hourglass symbols for each of the magazine cells has been replaced with a solid block, an open block, or a dash. When the reset is complete, press Enter to return to the Options Menu.



- \_\_\_ 22. Select SET LIBR MODE from the Options Menu and press Enter.
  - \_\_\_ 23. If the Magstar MP is configured to operate in split configuration, select DRIVE 1 and press Enter, otherwise continue with the next step.
  - \_\_\_ 24. Refer to "Library Modes of Operation" on page 115. Then, select the desired mode of operation (MANUAL, AUTOMATIC, or RANDOM) for tape drive 1 and press Enter.
- Note:** If the Magstar MP is configured to operate in Base Configuration, it is recommended to select the Random Mode of Operation. Drive 2 is not used when the Magstar MP is set in Base Configuration and Manual or Automatic modes of operation.
- \_\_\_ 25. If the Magstar MP is configured to operate in Base Configuration, continue with step 28.
  - \_\_\_ 26. Select DRIVE 2 and press Enter.
  - \_\_\_ 27. Select the desired mode of operation (MANUAL, AUTOMATIC, or RANDOM) for tape drive 2 and press Enter.
  - \_\_\_ 28. Select CANCEL and press Enter until the Options Menu is reached.
  - \_\_\_ 29. Continue at step 37.

#### **Model C01**

- \_\_\_ 30. Determine whether there is a cartridge in the drive by looking at the display:
  - If \*UNLOAD DRIVE is displayed, no cartridge is in the drive.
  - If UNLOAD DRIVE (without an asterisk) is displayed, a cartridge is in the drive.
- \_\_\_ 31. If a cartridge is loaded in the tape drive, select UNLOAD DRIVE from the Unload and Reset Menu and press Enter; otherwise continue with step 33.
- \_\_\_ 32. The cartridge will be unloaded from the drive and the status screen will be displayed. Press Enter to return to the Unload and Reset Menu.
- \_\_\_ 33. Select RESET DRIVE and press Enter, then select PROCEED and press Enter.
- \_\_\_ 34. The Magstar MP will reset, run power-on diagnostics, and check the magazine cells to determine if cartridges are present. The reset is complete when all movement in the library has stopped and the hourglass symbols for each of the magazine cells has been replaced with a solid block, an open block, or a dash. When the reset is complete, press Enter to return to the Options Menu.
- \_\_\_ 35. Select SET LIBR MODE from the Options Menu and press Enter.
- \_\_\_ 36. Select the desired mode of operation (MANUAL, AUTOMATIC, or RANDOM) and press Enter. (For additional information, see "Library Modes of Operation" on page 115.)

#### **Models C01 and C02**

- \_\_\_ 37. Press the Power switch (see **10** in Figure 79 on page 121) to the Off position.
- \_\_\_ 38. Continue with the Host (Initiator) Connection.

## Host (Initiator) Connection

The host (initiator) SCSI port must be quiesced (varied offline) before adding or removing any SCSI device. AS/400 system feature code 6501 provides two ports. Each 6501 port can support one Magstar MP 3570 Tape Subsystem. For optimum performance, there should only be one Magstar MP subsystem attached to each AS/400 feature 6501. An AS/400 system cannot be interconnected with any other system (including another AS/400) on the same SCSI bus.

- \_\_\_ 1. An interposer may be required at the initiator end of the SCSI cable (see Figure 30 on page 45). If so, install the appropriate interposer at the initiator (the host port where SCSI cable will be attached). Be sure to attach the interposer securely before attaching the SCSI cable to the interposer.

See Figure 37 for SCSI cable feature codes. See Figure 38 for SCSI cable connections to the host.

- \_\_\_ 2. For installation of Model C01, continue with "Model C01 Connections" on page 59.
- \_\_\_ 3. For installation of Model C02, continue with "Model C02 Connections" on page 61.

<b>Magstar MP Feature Code and P/N</b>	<b>Cable Length</b>
FC 5205 (P/N 49G6456) (SCSI Bus Jumper)	0.5 m (2 ft)
FC 5212 (P/N 49G6458)	12 m (39 ft)
FC 5218 (P/N 49G6459)	18 m (59 ft)
FC 5225 (P/N 08L6201)	25 m (81 ft)
FC 5245 (P/N 49G6457)	4.5 m (15 ft)

**Notes:**

1. Cable lengths greater than 18 m (59 ft) cannot be used with RS/6000 controller FC 2420. Cable lengths up to 25 m (81 ft) can be used with RS/6000 controller FC 2409, 2412, 2416, 6209.
2. On AS/400 systems, cable lengths up to 25 m (81 ft) can be used with feature code 2729, 6501, and 6534.

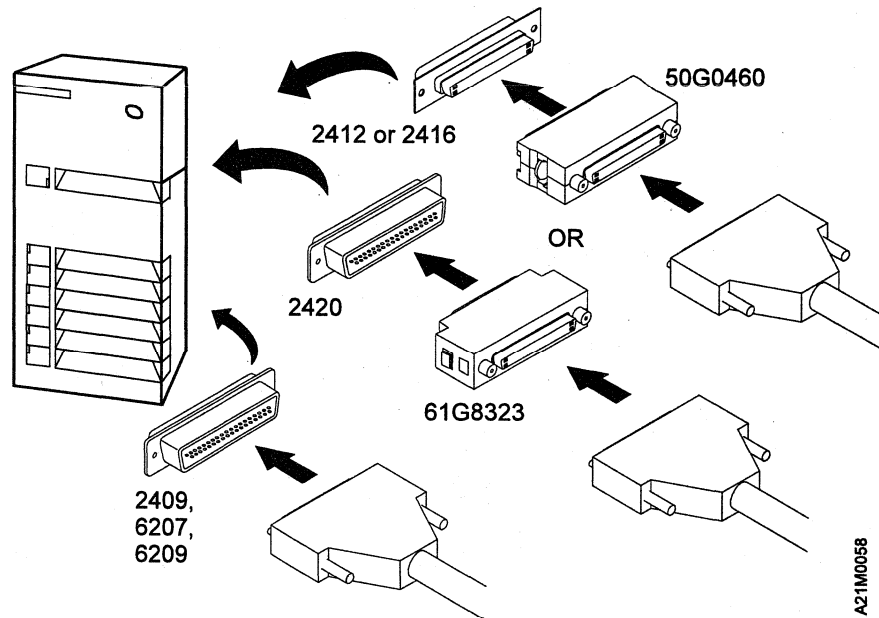

Figure 38. Installing the RISC System/6000 SCSI System Cable at the Host (Initiator)

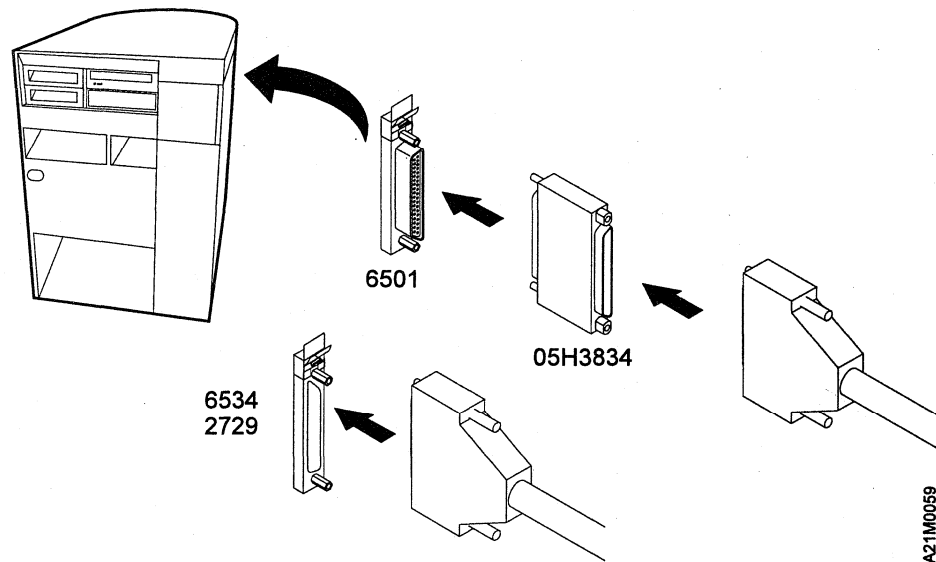

Figure 39. Installing the AS/400 SCSI System Cable at the Host (Initiator)

## Model C01 Connections

- 1. If not already removed, remove the back cover plate from the library. Give a one-quarter turn to each of the two white retaining fasteners on either side of the back cover plate to release them. Set the back cover plate aside.
- 2. If the Magstar MP is the first or only SCSI device connected in line to the initiator, connect the SCSI cable coming from the initiator to the leftmost SCSI connector on the back of the library (see **1** in Figure 40).
- 3. If the Magstar MP is not the first device on the SCSI bus, connect the SCSI interface cable coming from the next closest device to the leftmost SCSI connector on the back of the library (see **1** in Figure 40).

- 4. If this is the last device on this SCSI bus, locate the SCSI interface terminator (P/N 61G8324) and attach it to the rightmost SCSI connector on the back of the library (see **2** in Figure 40).
  - 5. If the library is not the last device on this SCSI bus, locate the SCSI interface cable to the next device and connect it to the unused, rightmost SCSI interface connector on the back of the library (see **2** in Figure 40).
- Note:** There are two SCSI connectors on the back of the Magstar MP library. When they are connected correctly, each of these connectors must have either a SCSI cable or a SCSI terminator attached.
- 6. Proceed to “Completing Connections for Model C01 or C02” on page 69.

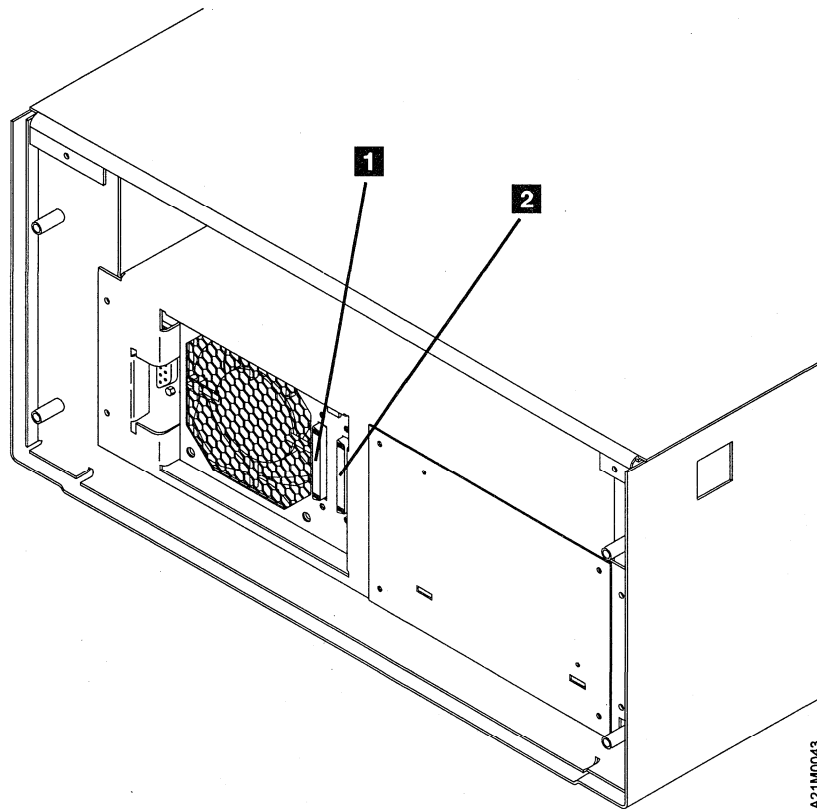

Figure 40. Rear View of Model C01 or C11

Figure 41 shows an example of a single Magstar MP attached to the host (initiator). Figure 42 shows an example of attaching multiple SCSI devices to a host.

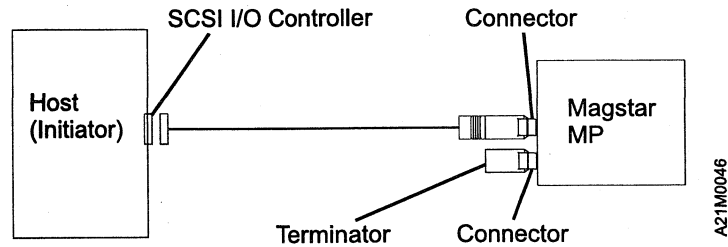

Figure 41. Example of Attaching One SCSI Device to the Host (Initiator)

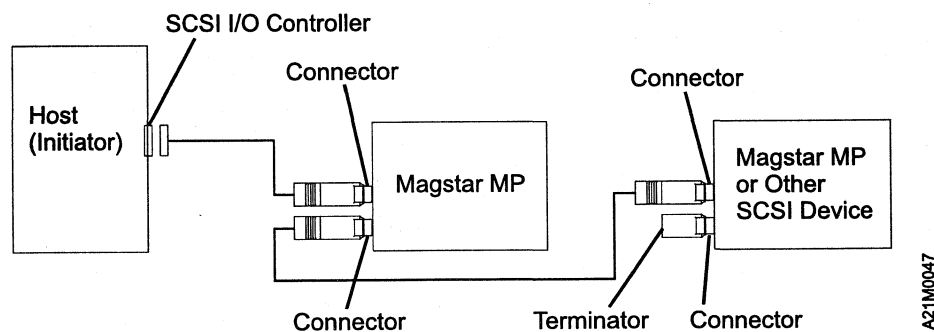

Figure 42. Example of Attaching Multiple SCSI Devices to the Host

## Model C02 Connections

- 1. If not already removed, remove the back cover plate from the library. Give a one-quarter turn to each of the two retaining fasteners on either side of the back cover plate to release them. Set the back cover plate aside.
- 2. For a Magstar MP Split Configuration setup, continue at step 8 on page 62. For a Magstar MP Base Configuration setup, continue with the following step. (See “Library Configurations” on page 117 for information about base and split configurations.)

### **Base Configuration:**

- 3. Ensure the SCSI Bus Jumper (P/N 49G6456) is connected to the rightmost SCSI connector on the back of tape drive 1, and to the leftmost SCSI connector on the back of tape drive 2. (See items **2** and **3** in Figure 43 on page 63).
- 4. If the Magstar MP is the first, or only, device in line connected to the initiator, connect the SCSI cable coming from the initiator to the leftmost SCSI connector on the back of the library. (See item **1** in Figure 43 on page 63).
- 5. If the Magstar MP is **not** the first device on the SCSI bus, connect the SCSI interface cable coming from the next closest device to the leftmost SCSI connector on the back of the library. (See item **1** in Figure 43 on page 63).

- \_\_\_ 6. If this is the last device on the SCSI bus, locate the SCSI interface terminator (P/N 61G8324) and attach it to the rightmost SCSI interface connector on the back of the library. (See item **4** in Figure 43 on page 63). If the library is **not** the last device on the SCSI bus, locate the SCSI interface cable to the next device, and connect it to the unused, rightmost SCSI interface connector on the back of the library. (See item **4** in Figure 43 on page 63).

- \_\_\_ 7. Continue at step 17.

**Split Configuration:**

- \_\_\_ 8. If one is installed, remove the SCSI Bus Jumper (P/N 49G6456) that connects the SCSI connector on the back of tape drive 1 to the SCSI connector on the back of tape drive 2. (See items **2** and **3** in Figure 43 on page 63).
- \_\_\_ 9. If tape drive 1 in the Magstar MP is the first, or only, device in line connected to the initiator, connect the SCSI cable coming from the initiator to the leftmost SCSI connector on the back of tape drive 1. (See item **1** in Figure 43 on page 63).
- \_\_\_ 10. If tape drive 1 is **not** the first device on the SCSI bus, connect the SCSI interface cable coming from the next closest device to the leftmost SCSI connector on the back of tape drive 1. (See item **1** in Figure 43 on page 63).
- \_\_\_ 11. If tape drive 1 is the last device on the SCSI bus, locate the SCSI interface terminator (P/N 61G8324) and attach it to the rightmost SCSI interface connector on the back of tape drive 1. (See item **2** in Figure 43 on page 63).
- \_\_\_ 12. If tape drive 1 is **not** the last device on the SCSI bus, locate the SCSI interface cable to the next device, and connect it to the unused, rightmost SCSI interface connector on the back of tape drive 1. (See item **2** in Figure 43 on page 63).
- \_\_\_ 13. If tape drive 2 in the Magstar MP is the first, or only, device in line connected to the initiator, connect the SCSI cable coming from the initiator to the leftmost SCSI connector on the back of tape drive 2. (See item **3** in Figure 43 on page 63).
- \_\_\_ 14. If tape drive 2 is **not** the first device on the SCSI bus, connect the SCSI interface cable coming from the next closest device to the leftmost SCSI connector on the back of tape drive 2. (See item **3** in Figure 43 on page 63).
- \_\_\_ 15. If tape drive 2 is the last device on the SCSI bus, locate the SCSI interface terminator (P/N 61G8324) and attach it to the rightmost SCSI interface connector on the back of tape drive 2. (See item **4** in Figure 43 on page 63).
- \_\_\_ 16. If tape drive 2 is **not** the last device on the SCSI bus, locate the SCSI interface cable to the next device, and connect it to the unused, rightmost SCSI interface connector on the back of tape drive 2. (See item **4** in Figure 43 on page 63).
- \_\_\_ 17. When the Magstar MP is correctly connected, all four SCSI connectors on back of the Magstar MP (see **1**, **2**, **3**, and **4** in Figure 43 on page 63) must have either a SCSI cable or a SCSI terminator attached.

## Connections to C02/C12

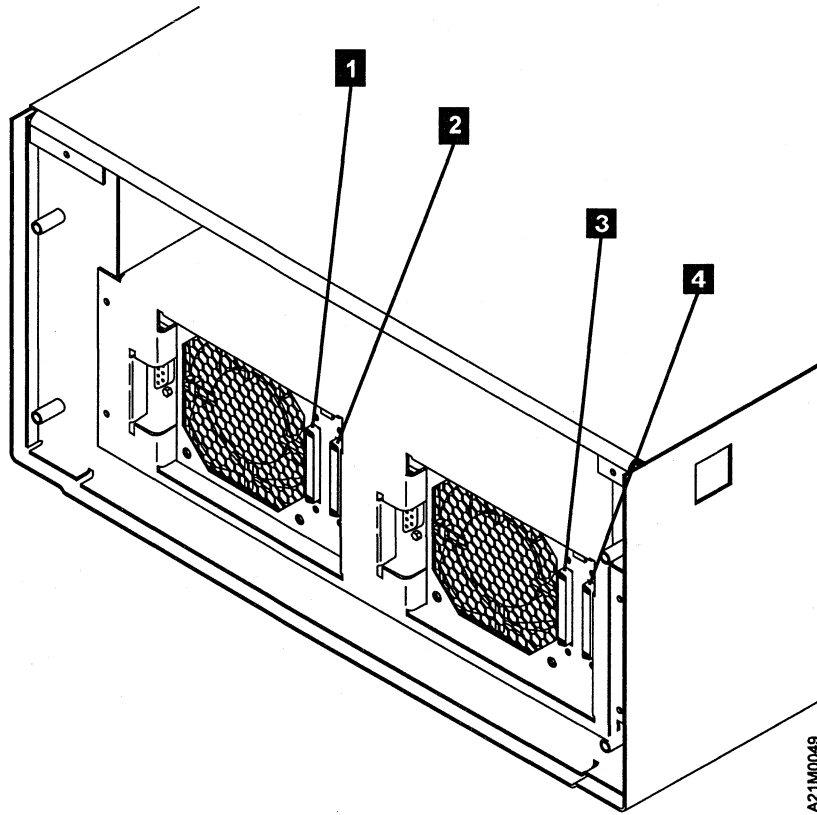

Figure 43. Rear View of Model C02 or C12

Figure 44 on page 64 shows an example of a single Magstar MP Model C02 or in Base Configuration attached to the host (initiator). Figure 45 on page 64 shows an example of a single Magstar MP Model C02 or in Base Configuration attached to the host (initiator) with multiple other SCSI devices.

**Base Configuration (single device to host)**

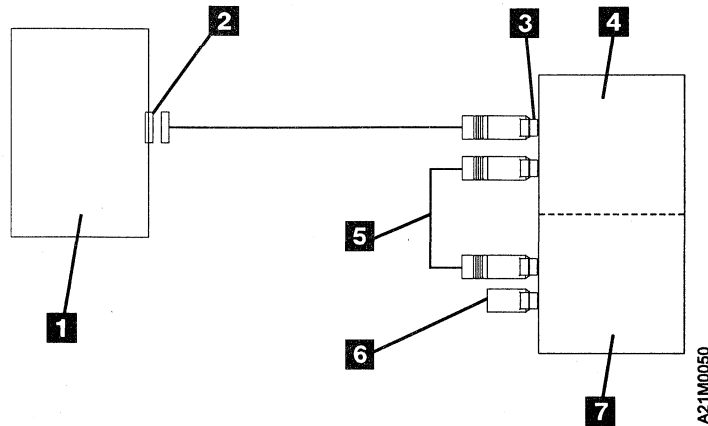

Figure 44. Example of Attaching One SCSI Device to the Host (Initiator)

**Note:** The Magstar MP Models C02 / C12 are in Base Configuration

- |                                  |                                  |
|----------------------------------|----------------------------------|
| <b>1</b> Host (Initiator)        | <b>5</b> SCSI Bus Jumper         |
| <b>2</b> SCSI I/O Controller     | <b>6</b> SCSI Terminator         |
| <b>3</b> SCSI Connector          | <b>7</b> Magstar MP Tape Drive 2 |
| <b>4</b> Magstar MP Tape Drive 1 |                                  |

**Base Configuration (multiple devices to host)**

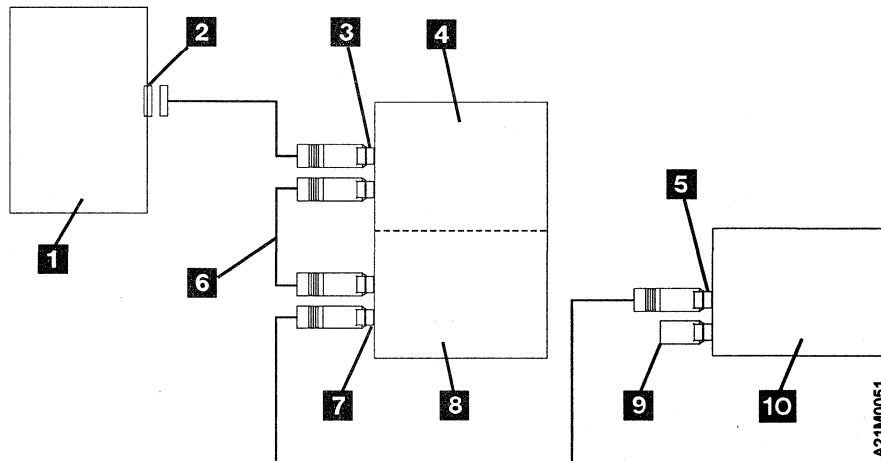

Figure 45. Example of Attaching Multiple SCSI Devices to a Host (Initiator)

**Note:** The Magstar MP Models C02 / C12 are in Base Configuration

- |                                  |   |
|----------------------------------|---|
| <b>1</b> Host (Initiator)        | <b>6</b> SCSI Bus Jumper                  |
| <b>2</b> SCSI I/O Controller     | <b>7</b> SCSI Connector                   |
| <b>3</b> SCSI Connector          | <b>8</b> Magstar MP Tape Drive 2          |
| <b>4</b> Magstar MP Tape Drive 1 | <b>9</b> SCSI Terminator                  |
| <b>5</b> SCSI Connector          | <b>10</b> Magstar MP or Other SCSI Device |



### Split Configuration:

Figure 46 shows an example of a single Magstar MP Model C02 or C12 in Split Configuration. Tape drive 1 **4** is a single SCSI device attached to the first host (initiator). Tape drive 2 **8** is attached to the second host (initiator) with multiple other SCSI devices.

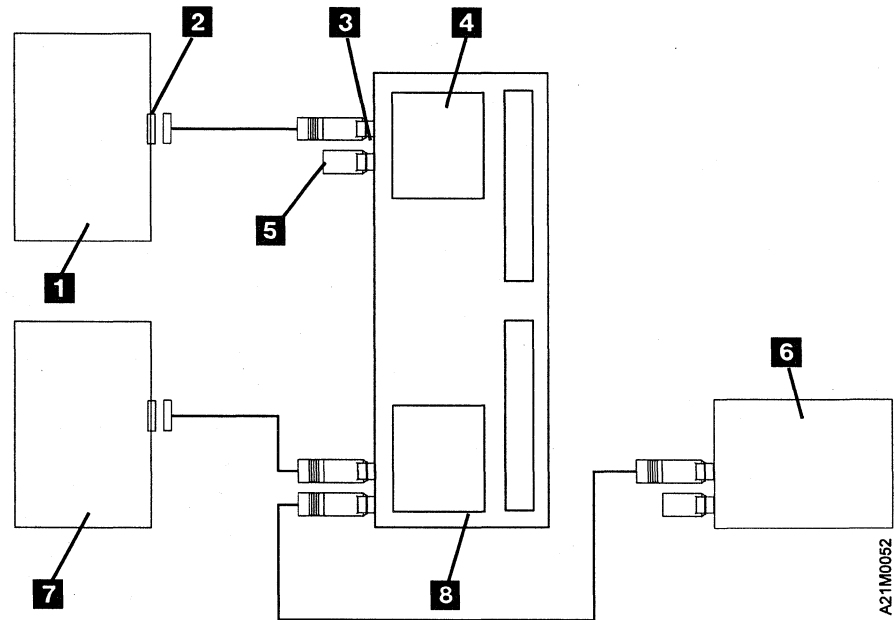

Figure 46. Attaching Magstar MP Models C02 or C12 In Split Configuration

- |                                  |  |
|----------------------------------|--|
| <b>1</b> Host (Initiator)        | <b>5</b> SCSI Terminator                 |
| <b>2</b> SCSI I/O Controller     | <b>6</b> Magstar MP or Other SCSI Device |
| <b>3</b> SCSI Connector          | <b>7</b> Host (Initiator)                |
| <b>4</b> Magstar MP Tape Drive 1 | <b>8</b> Magstar MP Tape Drive 2         |

## AS/400 FC 6501 Connections to C02

The following figures; Figure 47, Figure 48, Figure 49 on page 67, Figure 50 on page 67, and Figure 51 on page 68 illustrate connections to an AS/400 FC 6501.

### Base Configuration

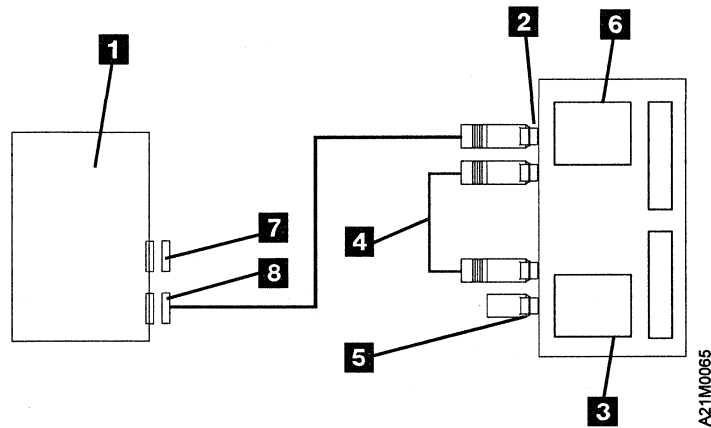

Figure 47. Base Configuration.

- |                                   |                                  |
|-----------------------------------|----------------------------------|
| <b>1</b> Host (Initiator) FC 6501 | <b>5</b> SCSI Terminator         |
| <b>2</b> SCSI Connector           | <b>6</b> Magstar MP Tape Drive 1 |
| <b>3</b> Magstar MP Tape Drive 2  | <b>7</b> Port 1                  |
| <b>4</b> SCSI Bus Jumper          | <b>8</b> Port 2                  |

### Split Configuration (single host, one IOP, one port)

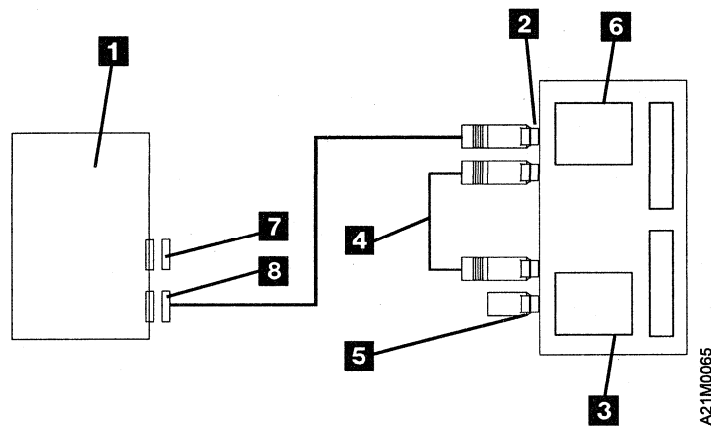

Figure 48. Split Configuration (single host, one IOP, one port).

- |                                   |                                  |
|-----------------------------------|----------------------------------|
| <b>1</b> Host (Initiator) FC 6501 | <b>5</b> SCSI Terminator         |
| <b>2</b> SCSI Connector           | <b>6</b> Magstar MP Tape Drive 1 |
| <b>3</b> Magstar MP Tape Drive 2  | <b>7</b> Port 1                  |
| <b>4</b> SCSI Bus Jumper          | <b>8</b> Port 2                  |

**Split Configuration (single host, one IOP, both ports)**

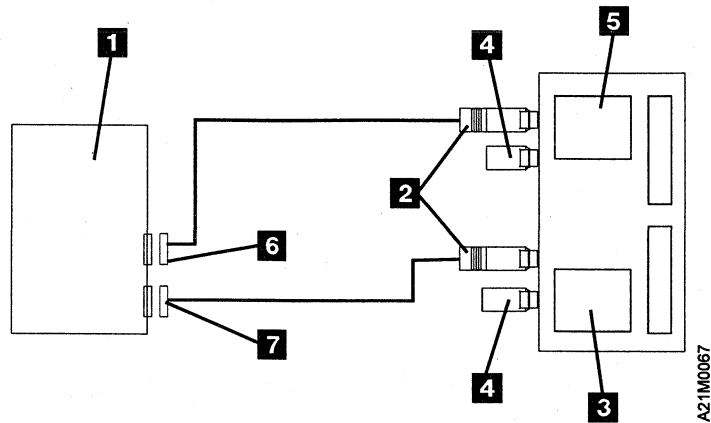

Figure 49. Split Configuration (single host, one IOP, both ports).

- |                                   |                                  |
|-----------------------------------|----------------------------------|
| <b>1</b> Host (Initiator) FC 6501 | <b>5</b> Magstar MP Tape Drive 1 |
| <b>2</b> SCSI Connector           | <b>6</b> Port 1                  |
| <b>3</b> Magstar MP Tape Drive 2  | <b>7</b> Port 2                  |
| <b>4</b> SCSI Terminator          |                                  |

**Split Configuration (two hosts)**

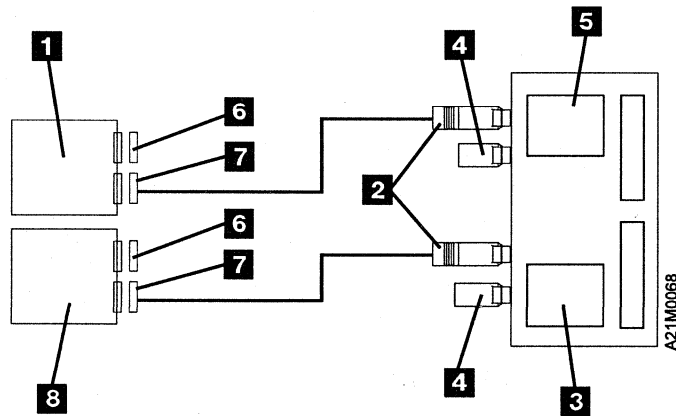

Figure 50. Split Configuration (two hosts).

- |                                      |                                      |
|--------------------------------------|--------------------------------------|
| <b>1</b> Host (Initiator) A, FC 6501 | <b>5</b> Magstar MP Tape Drive 1     |
| <b>2</b> SCSI Connector              | <b>6</b> Port 1                      |
| <b>3</b> Magstar MP Tape Drive 2     | <b>7</b> Port 2                      |
| <b>4</b> SCSI Terminator             | <b>8</b> Host (Initiator) B, FC 6501 |

**Split Configuration (single host, two IOPs)**

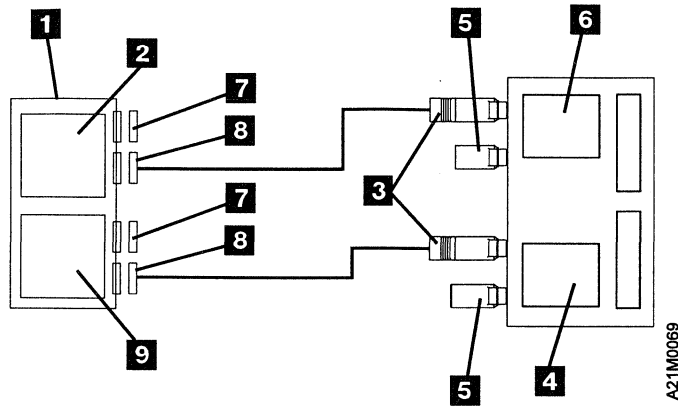

Figure 51. Split Configuration (single host, two IOPs).

- |   |   |
|---|---|
| <b>1</b> Host (Initiator)               | <b>6</b> Magstar MP Tape Drive 1        |
| <b>2</b> SCSI I/O Controller A, FC 6501 | <b>7</b> Port 1                         |
| <b>3</b> SCSI Connector                 | <b>8</b> Port 2                         |
| <b>4</b> Magstar MP Tape Drive 2        | <b>9</b> SCSI I/O Controller B, FC 6501 |
| <b>5</b> SCSI Terminator                |   |

## Completing Connections for Model C01 or C02

- 1. Re-install the rear cover plate. Position it properly then push the two hold-down fasteners in place and turn each one slightly until secure.
- 2. Ensure the power cord(s) are connected to the library and to the power source outlet selected.



- 3. Place the Power switch to the On position.
- 4. The initiator device drivers must be loaded to communicate with the library models. When this has been done, the library is ready for use. For attachment in RISC System/6000, Sun, HP-UX, Windows NT, or other Open System environments, see *IBM SCSI Tape Drive, Medium Changer, and Library Device Drivers*, GC35-0154 for instructions to install and configure the device driver. Tape device drivers are supplied for attachment to these systems. The AS/400 system has a tape device driver supplied as part of the operating system.

To install the device driver and configure the device with **default** parameters, use the following procedures:

### For RISC System/6000:

For additional information see *IBM SCSI Tape Drive, Medium Changer, and Library Device Drivers Installation and User's Guide*, GC35-0154.

- Performing the Default AIX Installation

Use the *installp* utility for installation. The software is always committed after installation. Insert the Tape Device Driver/AIX Enhanced diskette into the diskette drive on the workstation.

**Note:** You must have *root* authority to perform the commands in this section.

To install the device driver, enter the following command from the command line:

```
installp -acXd /dev/rfd0 Atape.driver
```

If the same version of *Atape.driver* is installed, then use the *installp* command with the *-F* flag to force an installation. The installation procedure automatically deconfigures any devices from the device driver and reconfigures them after the new driver is installed.

Enter the following command to list the currently installed version of *Atape.driver*:

```
lslpp -l Atape.driver
```

- **Configuring the Magstar MP**

After the driver software is installed and a Magstar MP is connected to the adapter card, the Magstar MP can be configured and made available for use. Access to the Magstar MP is not provided until the Magstar MP is configured.

Configure a Magstar MP 3570 Tape Subsystem by using **one** of the following procedures:

- a. Enter the following command with no parameters:

```
cfgmgr
```

The command automatically configures all devices known to the *Atape.driver*, including any new Magstar MP devices.

- b. Enter the following command to verify that the configuration completed successfully:

```
lsdev -Cc tape
```

**For AS/400:**

Ensure the AS/400 system value for Auto Configure Devices is set to **ON** and that all required PTFs are installed.

Turn the power on. If the Magstar MP is not recognized by the host (initiator), confirm that the required PTFs are installed and re-IPL the AS/400 IOP card to which the Magstar MP is attached.

**For other systems:**

For other system attachments see *IBM SCSI Tape Drive, Medium Changer, and Library Device Drivers Installation and User's Guide*, GC35-0154 for instructions to install and configure the device driver.

- **5.** Model C01 or C02 is now ready for operation with the host (initiator). To ensure the read/write functions are being performed properly, run a short program from the host (initiator).

The advanced user can refer to the following sections in the “Common Procedures” chapter of the Magstar MP Maintenance Information to verify that the read and write functions are performing properly:

**For RISC System/6000:**

“Checking the SCSI Attachment in an AIX Environment”

**For AS/400:**

“Checking the SCSI Attachment in an AS/400 Environment”

**For Sun:**

“Checking the SCSI Attachment in a Sun Environment”

**For HP-UX:**

“Checking the SCSI Attachment in an HP-UX Environment”

**For Windows NT:**

“Checking the SCSI Attachment in a Windows NT Environment”

---

## Removing or Relocating Models C01 or C02

If an installed Magstar MP 3570 Tape Subsystem must be either disconnected or relocated to a different system, the service representative must park the drive loader mechanism to protect it during shipping. If the Magstar MP is being moved only a short distance, load a scratch cartridge in the tape drives instead of requiring a service representative to park the loader mechanism. Perform the following steps in the order shown:

- \_\_\_ **1.** If your initiator has software aids for system upgrades, installations, or relocations, execute that software and follow the instructions provided with the software.
- \_\_\_ **2.** Ensure that all tape cartridges used by the subsystem have been removed from the subsystem.
- \_\_\_ **3.** To remove the cleaner cartridge from the cleaner cartridge storage cell inside the housing of the subsystem, select the Remove Cleaner Tape option from the Clean menu. The library will automatically put the cleaner cartridge into the export position of the priority cell where the operator can remove it.
- \_\_\_ **4.** If the Magstar MP is being moved only a short distance, first load a scratch cartridge in each tape drive before turning the power off; otherwise contact the service representative to complete the procedure by following the instructions in the Magstar MP Maintenance Information Manual.





---

## Chapter 8. Customer Installed Rack-Mounted Models C21 and C22

The IBM Magstar MP 3570 Tape library Models C21 and C22 are designed only for installation in the IBM Netfinity Rack (9306900) or NetBAY22 Rack (9306200). They can be attached to IBM Netfinity 5500 or 7000 and IBM PC Server 325 or 330 systems that support attachment with an included adapter card.



The general caution symbol identifies conditions where caution must be used. Ensure the rack is secured so it does not move.



The electrical caution symbol identifies electrical hazards where extreme caution must be used. Ensure the library power cord is the last cord plugged in.

While performing the following process, watch for pinch hazards. Be cautious of moving parts since they may create a pinch hazard. It may be helpful for you to check off each step as you proceed to install your 3570 hardware and verify that its installation is complete and successful.

- \_\_\_ Step 1. Use Figure 52 on page 74, Figure 53 on page 75, and Figure 54 on page 75 to inventory and identify the components in your 3570 shipment. Reference these lists to ensure you have all the necessary parts before you begin your installation, they are helpful references during the actual build phase of your 3570 library. (In the following installation pictures, block numbers **1** through **20** represent items in your hardware ship group. All other block numbers are referenced for description only.)

Figure 52. 3570 Drive Models C21 and C22 Rack-Mounted Hardware Ship Group

Bill Pkg Number	Part Number	SubPart Number	Quantity	Description
08L6486 <sup>1</sup>				
	5H2463		1	Cleaning Cartridge
	5H9527		1 <sup>2</sup>	<b>16</b> 0.5m SCSI Cable
	8L6187		1	Media Cartridge
	8L6250		1	3570 Maintenance Instruction Manual
	8L6251		1	Operator Guide GA32-0345-04
	13F9961		1 <sup>3</sup>	<b>19</b> 110v Line Cord
	34G0253		1 <sup>3</sup>	<b>20</b> 250v Line Cord
	49G6598		2	10 Cartridge Magazine
	08L6310			Tape Device Driver Kit
	8L6517			Adaptec Card Kit Adapter
		05H9651	1	<b>17</b> 4.5 SCSI Cable
		59H4231	1	Card
		61G8324	1	<b>18</b> Terminator
08L6488				Tray and Slide Assembly
			1	Left Slide
			1	Tray with Right Slide
	1621191		3 <sup>4</sup>	<b>4</b> M4x10 Pan Head Screw
			3 <sup>4</sup>	<b>5</b> M4x10 Phillips Head Screw
	1622403		3	<b>9</b> M4 Nut
08L6489				Slide Tray Hardware
	8L6502		3	<b>7</b> M4 Caged Nut
	8L6557		1	<b>11</b> M3 and M4 Allen Wrenches
	12J5288		11	<b>8</b> M6 Caged Nuts
	1621510		3	<b>2</b> M4x10 Socket Head Screw
	1621950		11	<b>6</b> M6x12 Socket Button Head Screw
08L6255				Cable Hardware
	5H2629		1	<b>13</b> SCSI Bracket Clamp
	5H9208		1	<b>15</b> Articulated Arm
	8L6495		1	<b>12</b> SCSI "Z" Bracket
	8L6501		1	<b>14</b> Pivot Hinge
	1159519		12	<b>10</b> Tie Strap
	1621465		2	<b>1</b> M5x8 Socket Head Screw
	1621519		1	<b>3</b> M5x12 Socket Head Clamp Screw
	1624778		6 <sup>5</sup>	M5x12 Bracket Screw
	74F1823		3 <sup>5</sup>	M5 Nut Clip

1. This bill number for Model C21 is 08L6485.
2. Use on Model C22 dual-drive single-host only.
3. There is one cable each for Model C21 and two cables each for Model C22.
4. The pan head screws and the Phillips head screws are interchangeable. You will receive either three of one or three of the other.
5. Not used in Netfinity rack installation.

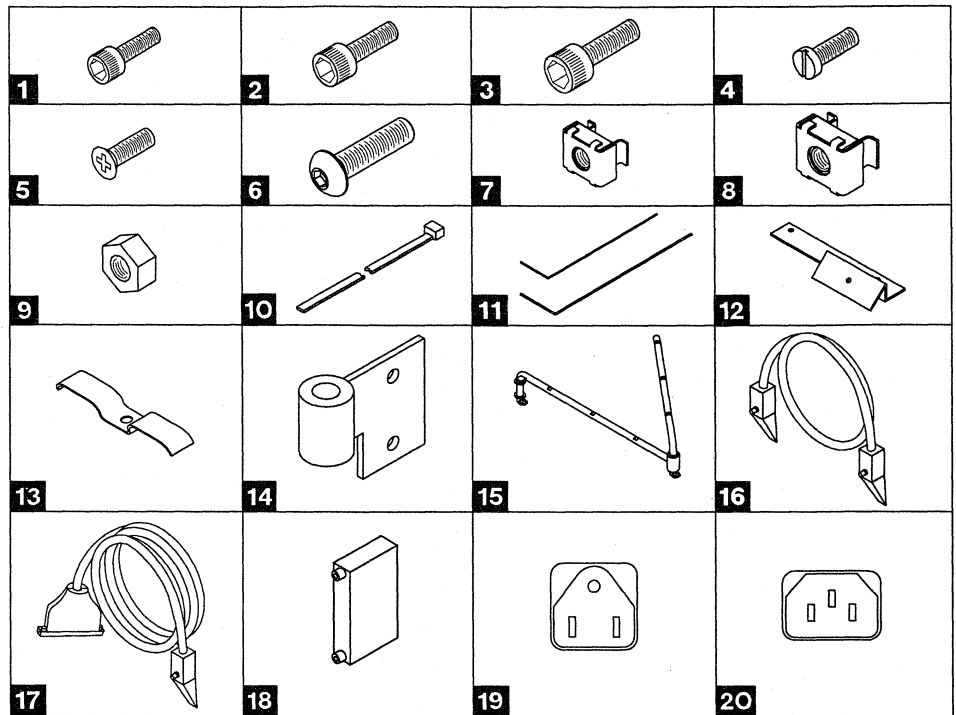

A21M0112

Figure 53. 3570 Drive Models C21 and C22 Rack-Mounted Hardware Ship Group Parts and Tool Diagram

Figure 54. 3570 Drive Models C21 and C22 Rack-Mounted Hardware Ship Group Parts and Tool Listing

Item Number	Description	Part Number
<b>1</b>	M5x8 Socket Head Screw	1621465
<b>2</b>	M4x10 Socket Head Clamp Screw	1621510
<b>3</b>	M5x12 Clamp Screw	1621519
<b>4</b>	M4x10 Pan Head Screw	1621191
<b>5</b>	M4x10 Phillips Head Screw	
<b>6</b>	M6x12 Socket Button Head Screw	1621950
<b>7</b>	M4 Caged Nut	8L6502
<b>8</b>	M6 Caged Nut	12J5288
<b>9</b>	M4 Nut	1622403
<b>10</b>	Tie Strap	1159519
<b>11</b>	M3 and M4 Allen Wrench	8L6557
<b>12</b>	SCSI "Z" Bracket	8L6495
<b>13</b>	SCSI Bracket Clamp	5H2629
<b>14</b>	Pivot Hinge	8L6501
<b>15</b>	Articulated Arm	5H9208
<b>16</b>	0.5 SCSI Cable	5H9527
<b>17</b>	4.5 SCSI Cable	5H9651
<b>18</b>	Terminator	61G8324
<b>19</b>	110v Line Cord	13F9961
<b>20</b>	250v Line Cord	34G0253

- | \_\_\_\_\_ Step 2. Position the 3570 shipping container near the rack.
- | a. When you are installing either Model C21 or Model C22 in a rack, you are instructed to locate components by Electronic Industry Association (EIA) rack unit and hole location. An EIA unit is composed of three holes. (See Figure 55 on page 77 for an example.) All hole locations are specified within contiguous EIA rack units, and are square shaped.
- | b. Because of the 3570 weight, it is recommended that the 3570 be installed as low as possible in the rack. From a safety operator-usability view, the 3570 slides should be installed no higher than EIA unit number 23 and no lower than EIA number 10.
- | c. The 3570 requires six EIA units of space. (Each EIA unit consists of three holes in the rack strips.) From the front of the machine, the EIA strips are identified only on the right front and rear strips. Take care to correctly identify the remaining two strip locations on the left front and rear for their mounting holes. This will ensure that the tray will be installed in a level orientation.
- | \_\_\_\_\_ Step 3. Locate the physical area in the rack where the 3570 is to be installed. See Figure 55 on page 77 as your reference for the captured nut locations. The front view shows the frontal left and right EIA strips as viewed from the rack front. The rear view shows the rear right and left EIA strips as viewed from the back of the rack. Items **7** and **8** refer back to the list of items in Figure 53 on page 75.

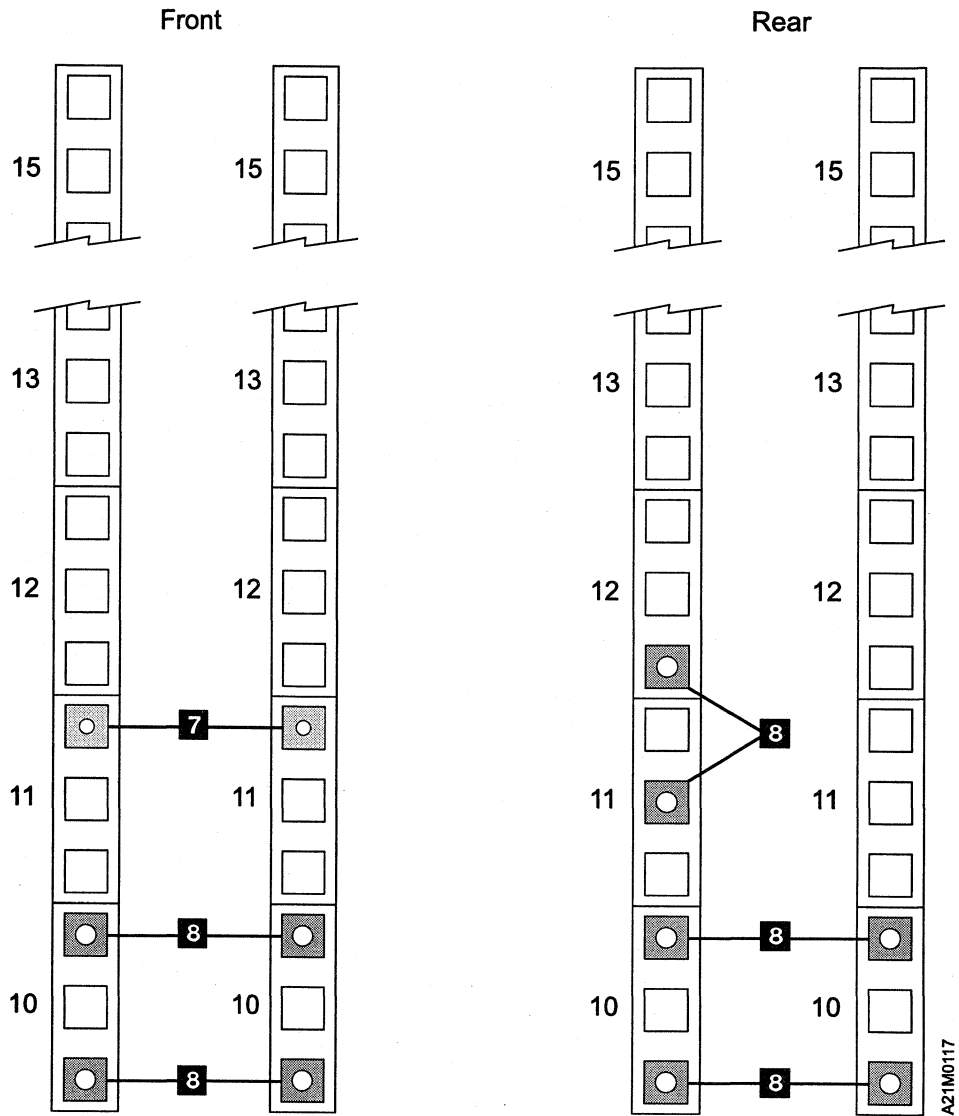

Figure 55. EIA Specification



**CAUTION:**  
Removal of the door requires two people.

- Step 4. It is necessary to remove the front door of the Netfinity rack to install the slide assemblies.
- Step 5. With one person holding the door, the other removes the j-pins from the bottom to top. Once the pins are out, slide the door off the hinges. Store the door in a safe place for later reinstallation. Insert the j-pins back into the hinges to avoid loss. It is suggested that door installation j-pins are re-inserted from top to bottom.

## Install Supporting Slides and Tray

It is important for you to understand the structure of your Netfinity rack. For the purposes of installing a 3570 library, familiarize yourself with the EIA strips. These strips are used to denote groupings of three holes each which, in turn, are numbered. Each group of three holes is called an *EIA unit*. Six EIA units must be available to install a 3570 library; within those six EIA units, the slide will be mounted to the bottom EIA.

- \_\_\_ Step 1. To prepare for this task, and all successive tasks, refer to the parts shown in Figure 53 on page 75. The tools you will be using to install the 3570 include: a flat blade screwdriver, a number two Phillips screwdriver and an adjustable wrench. Two hex wrenches are included in the machine package.
- \_\_\_ Step 2. Determine in which rack location the 3570 will be installed; count six EIA units to accommodate for its height and mark the lower EIA units on the right and left sides in the front and rear of the rack. These EIA units identify the base upon which you will be developing your build. See Figure 56.

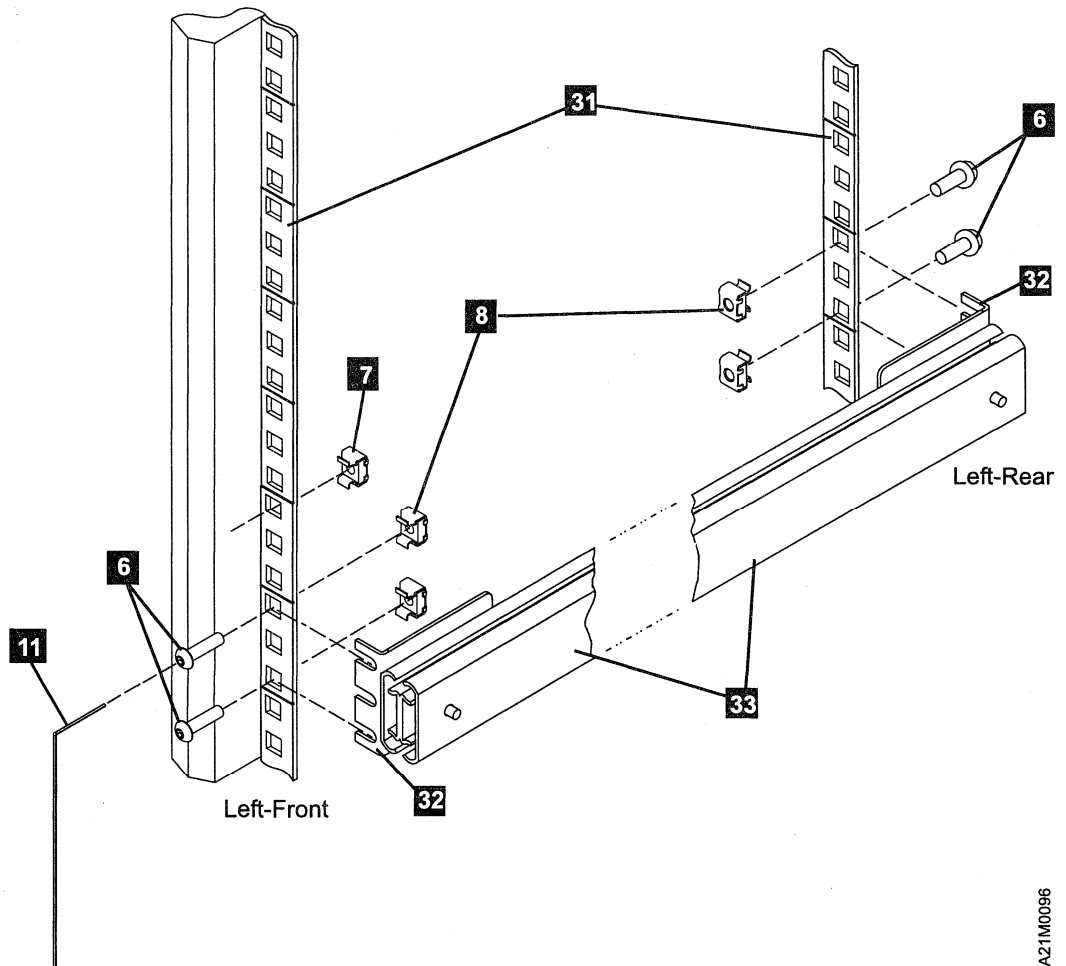

Figure 56. Attaching Left-Hand Slide and Bracket Assembly

A21M0096

- \_\_\_ Step 3. Use a flat blade screwdriver to install all of the caged nuts, you will have to view three assembly pictures. Use a flat blade screw driver to press the capture edge of the nut into the EIA strip.
- \_\_\_ Step 4. **Read the following before doing steps 5a, 5b, 5c, and 5d.** These caged nuts must be pressed into the square hole [using a flat blade screw driver]. Once they are seated, they will maintain their position. Next, using the Allen wrench **11** supplied, insert the socket button head screws **6** through the EIA strip and into the caged nuts **8**. Leave the screws loose enough to insert the slide mounting brackets **32** between the screw head and the EIA strip **31**. See Figure 55 on page 77 for referencing captured nut installations.
- \_\_\_ Step 5.
  - \_\_\_ Step a. See Figure 56 on page 78 to install four M6 caged nuts **8** for the left side slide. Insert and leave the corresponding screws **6** loose.
  - \_\_\_ Step b. See Figure 57 on page 80 to install four M6 caged nuts **8** for the right side slide. Insert and leave the corresponding screws **6** loose.
  - \_\_\_ Step c. See Figure 56 on page 78 and Figure 57 on page 80 to insert one each M4 caged nuts **7**. These will be used to retain the 3570 from free sliding out of the rack.
  - \_\_\_ Step d. See Figure 61 on page 84 to install two M6 caged nuts **8** for the articulated arm hinge. Viewed from the front of the rack, install the caged nuts on the right rear EIA strip. Ensure there is one open hole above the top slide caged nut.
- \_\_\_ Step 6. It is suggested that you have another person assist you in steps 6 through 8 on page 80. Reference Figure 56 on page 78 and take the left-hand slide assembly **33** and, ensuring that the slide (the part without mounting brackets **32**) extends toward the front of the rack, install the assembly. It is necessary to lengthen the slide mounting brackets to correctly mount them to the outside of the rack EIA strip. To accomplish this, **do not** loosen the **front** mounting bracket screws. Adjustment must be made with the *rear* mounting bracket screws.

**Slide Bracket Adjustment Procedure:**

  - a. You must adjust each slide to the Netfinity Rack.
  - b. Loosen the rear bracket screws. Capture the front slide bracket under the button head screws, adjust the rear slide bracket to fit under the rear button head screws, and snug the rear bracket screws.
  - c. Remove the left-hand slide assembly, tighten the rear bracket screws, and **do not** install the left-hand slide assembly yet.
  - d. Before permanently installing the left-hand slide assembly to the EIA strip, use it as a template (or gauge) to adjust and tighten the right-hand slide and tray assembly rear brackets.
- \_\_\_ Step 7. Once the right-hand slide is adjusted, you can proceed to install the left slide assembly onto the rack. Firmly tighten the front and rear screws **6** into the EIA strips.

\_\_\_ Step 8. See Figure 57 to install the right-hand slide and tray assembly **35**.

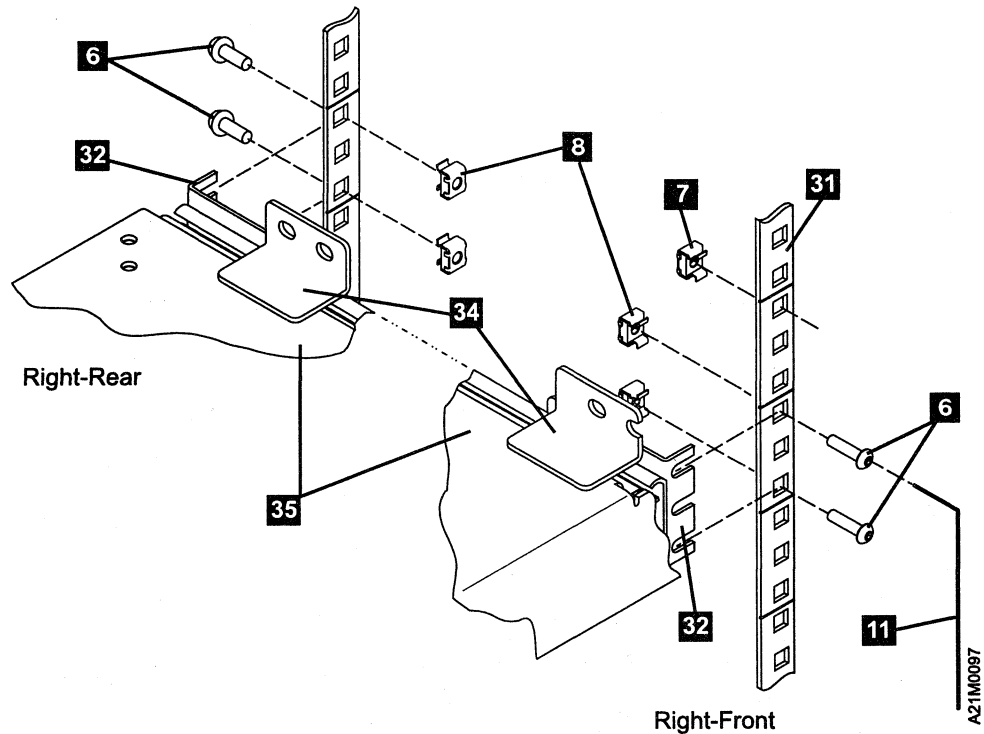

Figure 57. Attaching Right-Hand Slide, Bracket, and Tray Assembly

- \_\_\_ Step a. For good sense, this is a two person operation; one in the front and one in the rear of the rack. Ensure the four library mounting tabs **34** are pointing in the up orientation. Looking from the front, tilt the left side of the slide and tray assembly up and insert it into the rack area. (The square hole in the center of the tray can be used as a hand hold.) Insert the brackets **32** on the outside of the EIA strips between the screw heads and the EIA strip. As you do this, lower the left side, thus forcing the whole assembly to the right-most position. This will ensure that the tray is at a level orientation. Do not tighten slide assembly screws **6** at this time.



\_\_\_ Step 9. See Figure 58 to attach the tray to the left-hand slide.

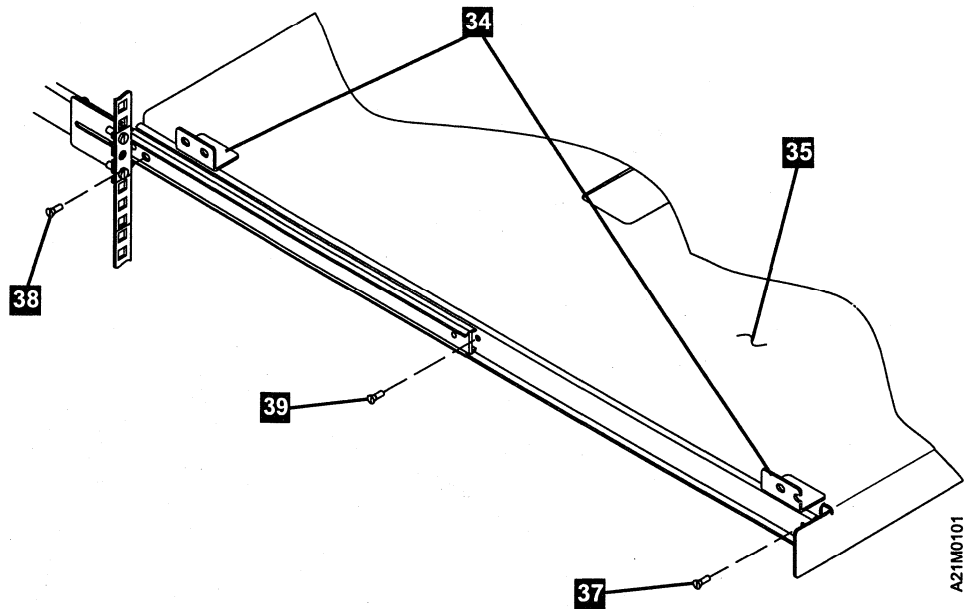

Figure 58. Attaching Tray to Left-Hand Slide

\_\_\_ Tabs **34** on tray **35** are facing upward.

\_\_\_ Step a. Now, look back to Figure 57 on page 80 and securely tighten the front and rear right slide assembly screws **6** ) onto the EIA strip.

\_\_\_ Step b. See Figure 58, slide the tray out to its fully extended locking position.

- 1) Get the three Phillips-head or pan-head screws (items **4** or **5** are referenced as items **37** , **38** , and **39** ).
- 2) To install the front screw **37** , slightly raise the tray and align the slide clearance hole to the threaded hole in the tray.
- 3) Install the rear screw **38** .
- 4) Next, unlock and move the slide tray inward to align the center screw hole **39** , and insert the screw.

\_\_\_ Step c. Tighten all screws **37** , **38** , and **39** . Thread the three nuts **9** onto the three screws you have just installed and tighten the nuts.

## Installing the Rack-Mounted 3570

The following notices apply to installing the 3570 into a Netfinity rack.



**CAUTION:**

Model C21 weighs approximately 24 kilograms (53 pounds). It takes two people to safely lift this unit.

**CAUTION:**

Model C22 weighs approximately 29 kilograms (64 pounds). It takes two people to safely lift this unit.

- \_\_\_ Step 1. Remove the 3570 library from the packing carton. This requires two people. Save the packing material in the empty box and set it aside.
- \_\_\_ Step 2. Remove the keys which are taped to the rear of the 3570 and set them aside for future use.

See Figure 59 to attach the 3570 to the rack tray.

- \_\_\_ Step 3. Remove the four corner screws **40** from the library, one on each of the four corners. Set them aside because they will be used to attach the library to the tray at step 7 on page 83.

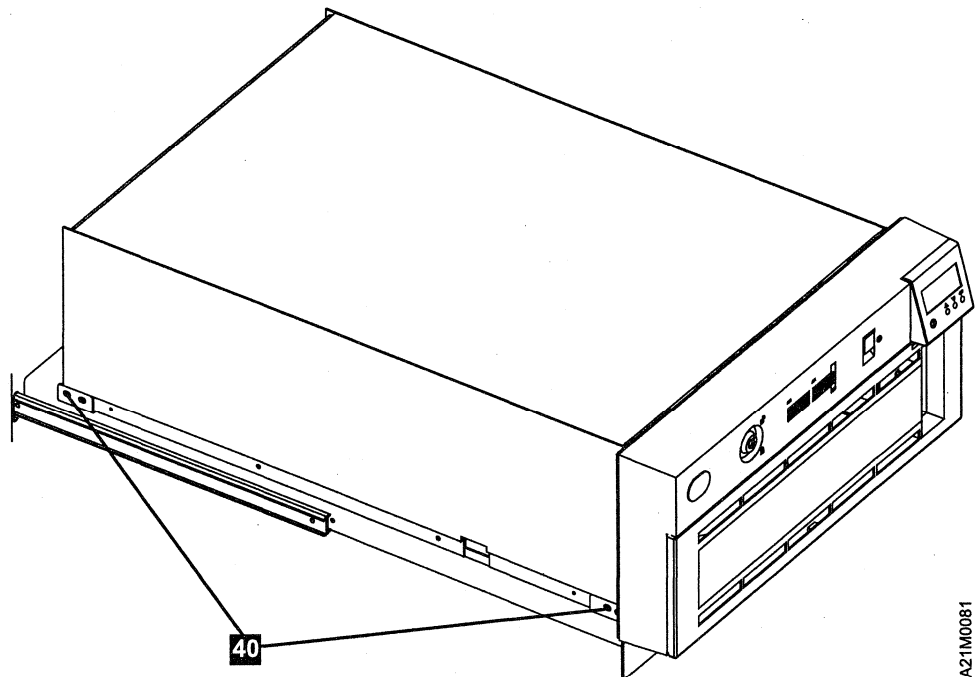

A21M0081

Figure 59. Attaching the 3570 to the Rack Tray

- \_\_\_ Step 4. **CAUTION:**  
As you slide the 3570 library tray assembly in or out of the rack, ensure you do not get your hand caught between the library and the rack. Also, when you service the 3570, ensure the slide and tray assembly is fully extended and locked.
- \_\_\_ Step 5. Extend the slide and tray assembly all the way out. Ensure that the sliding tray assembly is locked in the extended position.

- \_\_\_ Step 6. **You must have assistance to proceed.** Lift the 3570, **with assistance**, and set it on the tray. Ensure that the screw holes in the 3570 align with the holes in the mounting tabs on the tray.
- \_\_\_ Step 7. Secure the four corners **40** of the 3570 frame to the four tray mounting tabs. Ensure that the mounting tabs of the tray are on the outside of the 3570 frame. The mounting tabs have two holes; use the mounting holes closest to the rear of the library in the frame. Re-insert the four previously removed screws **40** and tighten.

**Note:** Once the library is secured to the tray, unlock the tray security latch (located at the center of the right-hand slide, and carefully and slowly slide the tray back into the rack frame. Check to ensure the front of the 3570 is flush to the front of the rack frame. If it protrudes, check that the correct mounting tab holes have been used. If the library protrudes from the rack, the door, once re-installed, will not close.

- \_\_\_ Step 8. See Figure 60 to install the cable strain-relief "Z" bracket **12** at the standoffs **41** at the rear of the library. Use two socket head screws **1**.

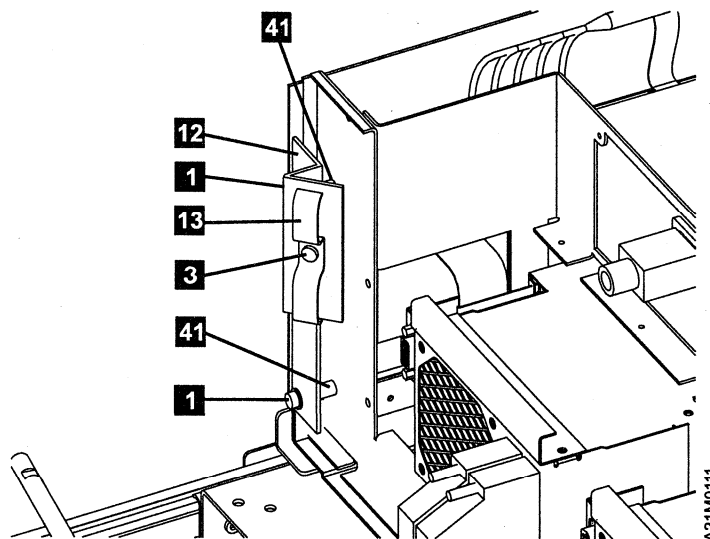

Figure 60. Attaching Cable Strain-Relief "Z" Bracket and Clamp

- \_\_\_ Step 9. Install the strain relief clamp **13** on the strain-relief "Z" bracket with socket head clamp screw **3**. Leave the screw loose at this time. Power and SCSI cables will be routed through the clamp in a later step.

- Step 10. See Figure 61 to install the pivot hinge **14**. Use two socket button head screws **6** through the pivot hinge and into the two caged nuts **8**. Tighten the screws. The pivot hinge should be installed in the EIA unit just above the right rear slide mounting position.

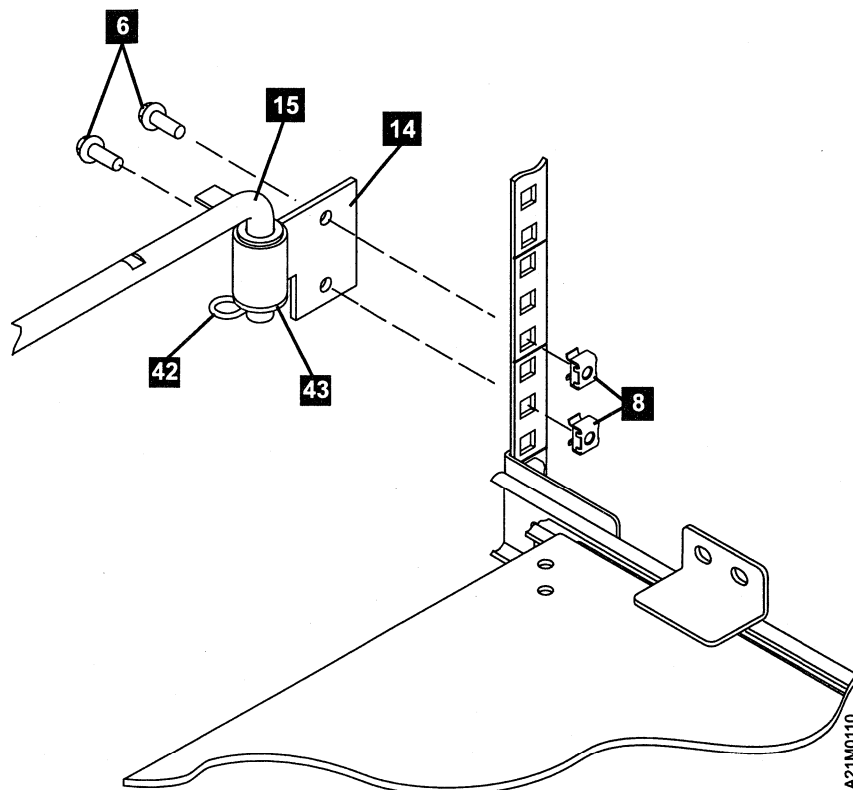

Figure 61. Attaching Cable Arm Hinge and Bracket

- Step 11. Install the articulated arm **15** in the pivot hinge as shown. Use the following steps.
- Step a. Remove the retaining pin **42** and washer **43** from the arm assembly. You may have to pry the pin from the arm. You can accomplish this by inserting the blade of a screw driver through the pin then prying the pin off.
  - Step b. Insert the assembly into the hinge.
  - Step c. Install the washer **43** on the arm assembly (if there is a washer in the kit) and capture the washer as you reinsert the retaining pin **42**.

---

## Attaching SCSI and Power Cables to Models C21 and C22

This section describes the various cabling configurations that are possible. Choose the one which is required for your application. The SCSI cabling options are dependent on the selection of base library mode (base) or split library mode (split host), and whether the library contains one or two tape drives.

### Configurations:

#### • BASE LIBRARY MODE CONFIGURATIONS:

- Single drive library with single host (Go to “Attaching SCSI and Power Cables to Model C21 (Single Drive with Single Host)” on page 86):
  - SCSI bus terminations are supplied by the host SCSI adapter card and a terminator plug on drive 1.
- Dual drive library with single host (Go to “Attaching SCSI and Power Cables to Model C22 (Dual-Drive Single-Host)” on page 89):
  - SCSI sockets on each drive are connected together by a short SCSI cable.
  - SCSI bus terminations are supplied by the host SCSI adapter and a terminator plug on drive 2.
- Dual drive library with dual hosts

**Note:** This configuration is **not** covered in this document.

- SCSI bus terminations are supplied by the SCSI adapter in each host.
- **Important:** Storage slot assignment and/or cartridge contention issues are handled by the host software.

#### • SPLIT LIBRARY MODE CONFIGURATIONS:

- Dual drive with dual host (go to “Attaching SCSI and Power Cables to Model C22 (Dual-Drive Split-Host)” on page 92 ):
  - SCSI bus terminations for each drive-host combination is accomplished with each host SCSI adapter card and a terminator plug on the associated drive.
  - The library firmware assigns one magazine (10 cartridges) to one drive-host combination and the other magazine (10 cartridges) to the other combination.

## Attaching SCSI and Power Cables to Model C21 (Single Drive with Single Host)



This section instructs you on the proper installation of electrical components. You must take care to read the safety instructions at the beginning of this manual (see "Safety Notices" on page xi) before you proceed.

- \_\_\_ Step 1. Ensure the rack power is off.
- \_\_\_ Step 2. Take the two types of power cords **19/20** and determine which one will seat into the rack power supply in the Netfinity Rack.

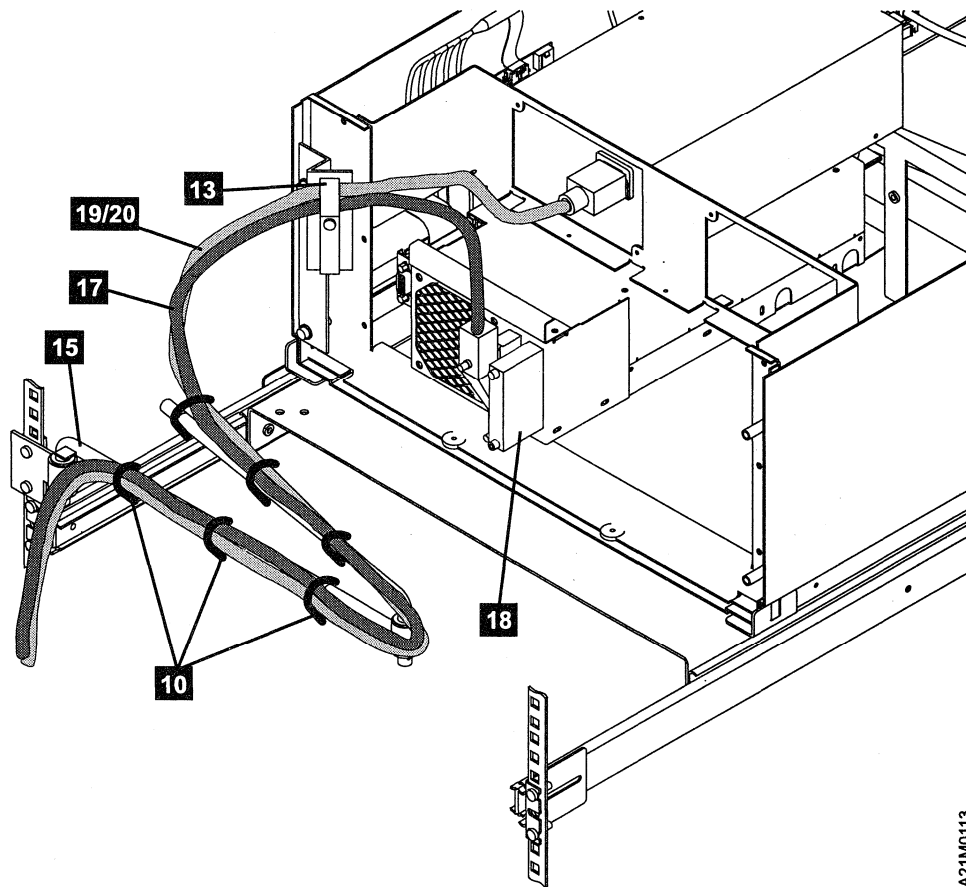

Figure 62. Model C21 cable Routing

- \_\_\_ Step 3. Install the power cord **19/20** into the rear of the 3570 drive 1 power supply. Route it through the upper wing of the clamp **13**), and let it temporarily hang there.
- \_\_\_ Step 4. Install, and finger-tighten, terminator **18** into the right-most 68-pin socket.
- \_\_\_ Step 5. Install the long SCSI host cable **17**. Plug the right-angled plug into the left-most 68-pin socket (see Figure 62) so the cable is looped upward. Route it to the upper wing of the clamp (loop the cable so it

does not extend above the top of the 3570 you are installing). With both the power cord and the SCSI cable captured in the upper wing of the clamp, tighten the screw.

- \_\_\_ Step 6. See Figure 63. Push the 3570 completely forward so it will lock into position, then extend the articulated arm to its full length toward the 3570 library.

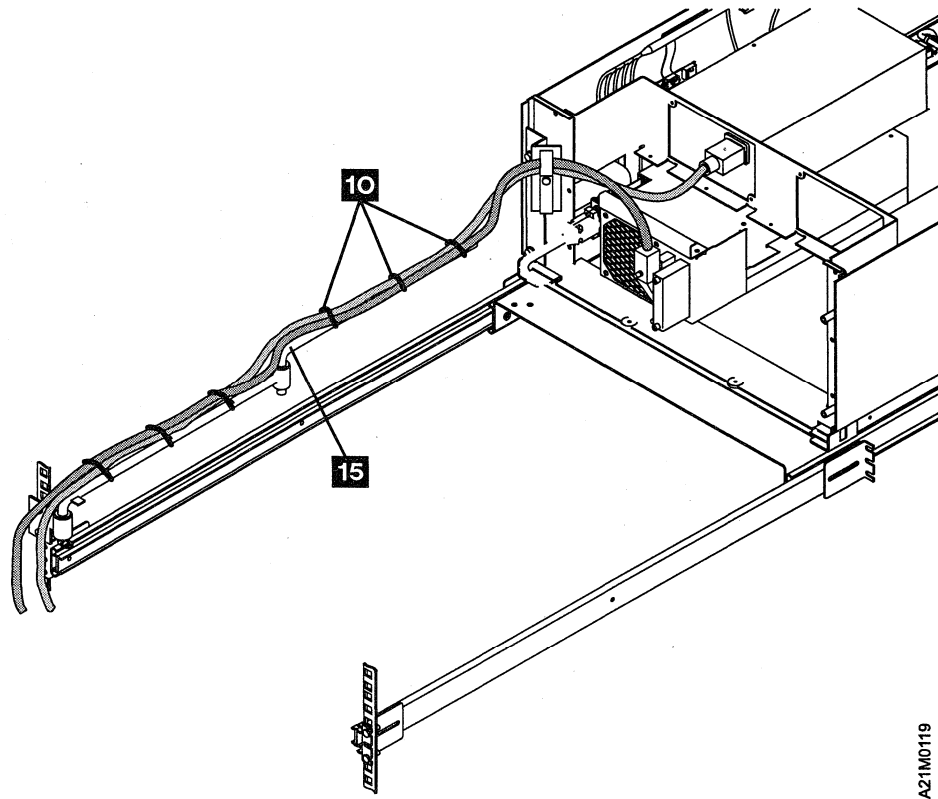

Figure 63. 3570 and Articulated Arm Extended for Model C22 Single Drive

**Note:** To cinch cable ties, note that the teeth of the cable ties are on the inside of the loop.

- \_\_\_ Step 7. Locate the cable ties **10** to the three flat sections on the articulated arm **15**. Avoid excessive cable loop between the library and the articulated arm. Firmly secure the cables to the forward arm section. The cable ties must be tight so they do not move as the articulated arm moves.
- \_\_\_ Step 8. Depress the tray security latch and bring the tray back into the rack area. With the articulated arm in an almost closed position, route the cables around the joint of the arm and secure the cables to the remaining arm section with cable ties. Tighten the cable ties.
- \_\_\_ Step 9. Push the tray to its extreme forward position to verify the cables will not be strained and to ensure the tray can lock into position without stress on the cables. After examining the cables, return the tray into the rack.
- \_\_\_ Step 10. Trim the cable tie ends flush to the head of the tie.
- \_\_\_ Step 11. To secure (lock) the 3570 library into the rack, refer to Figure 56 on page 78 and Figure 57 on page 80. Open the front door of the 3570

library. On the right and left sides are offset brackets. (You may have to adjust the brackets to locate the bracket hole to the captured nut **7**.) Place two socket head screws **2** through the bracket and into the M4 caged nut **7**. Tighten the screws.

\_\_\_ Step 12. Now is the time to re-install the front door.



**CAUTION:**

**Installing the door requires two people.**

To re-install the rack front door, have one person hold the door while the other installs the j-pins from top to bottom.



## Attaching SCSI and Power Cables to Model C22 (Dual-Drive Single-Host)



This section instructs you on the proper installation of electrical components. You must take care to read the safety instructions at the beginning of this manual (see "Safety Notices" on page xi) before you proceed.

- \_\_\_ Step 1. Ensure the rack power is off.
- \_\_\_ Step 2. Take the two types of power cords **19/20** and determine which one will seat into the rack power supply in the Netfinity Rack.

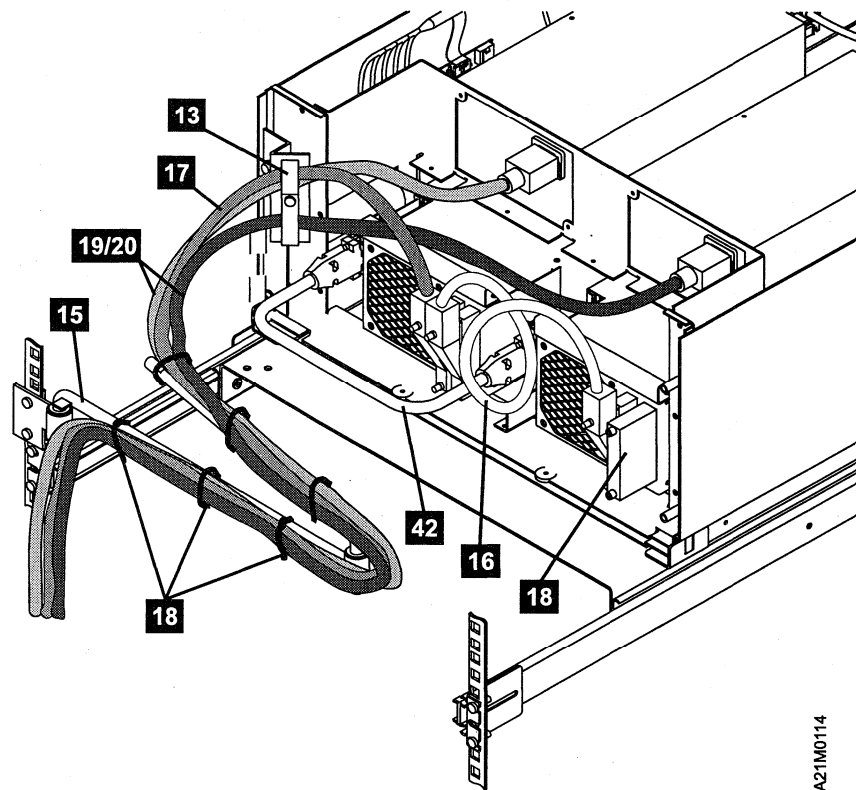

Figure 64. Model C22 (Dual-Drive Single-Host) Cable Routing

- \_\_\_ Step 3. Install the power cord **19/20** into the rear of the 3570 drive power supply (the left-most drive), route it through the upper wing of the clamp **13**, and let it hang there temporarily. Install the second power cord **19/20** into the rear of the 3570 drive power supply (the right-most drive), route it through the lower wing of the clamp **13**, and let it hang there temporarily.
- \_\_\_ Step 4. Install and finger-tighten terminator **18** into the right-most socket of drive 2.
- \_\_\_ Step 5. Install the long SCSI host cable. Insert the right-angled plug into the left-most 68-pin socket (see Figure 64) of drive 1 so the cable is looped upward. Route it to the upper wing of the clamp (loop the

cable so it does not extend above the top of the 3570 you are installing). With both the power cord **19/20** and the SCSI cable **17** from drive 1 captured in the upper wing of the clamp, and the power cord **19/20** from drive 2 captured in the lower wing of the clamp, tighten the screw.

- \_\_\_ Step 6. Take the short SCSI cable **16** and insert it into the right-most socket in drive 1 and loop it to the left-most 68-pin socket of drive 2.
- \_\_\_ Step 7. Install the RS422 cable (PN65F5399) **42**.
- \_\_\_ Step 8. See Figure 65. Push the 3570 completely forward so it will lock into position, then extend the articulated arm to its full length toward the 3570 library.

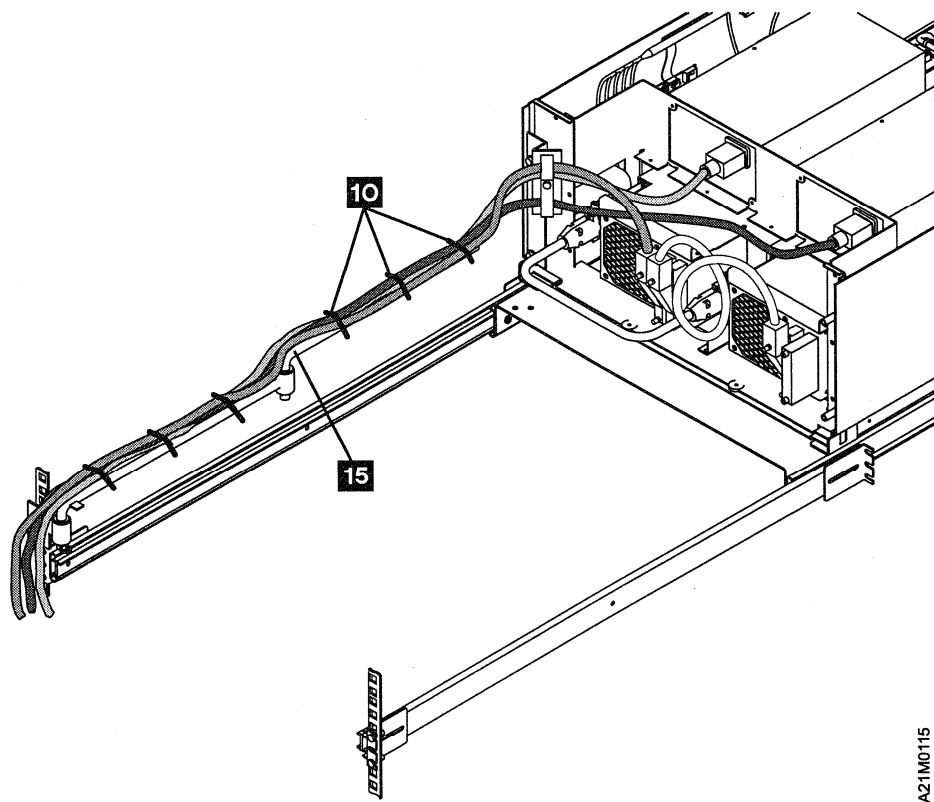

Figure 65. 3570 and Articulated Arm Extended for Model C22 Dual-Drive Single-Host

**Note:** In the use of cable ties, note that the teeth of the ties are on the inside as you make the cable tie into a loop.

- \_\_\_ Step 9. Locate the cable ties **10** to the three flat sections on the articulated arm **15**. Avoid excessive cable loop between the library and the articulated arm. Firmly secure the cables to the forward arm section. The cable ties must be tight so they do not move as the articulated arm moves.
- \_\_\_ Step 10. Depress the tray security latch and bring the tray back into the rack area. With the articulated arm in an almost closed position, route the cables around the joint of the arm and secure the cables to the remaining arm section with cable ties. Tighten the cable ties.

- \_\_\_ Step 11. Push the tray to its extreme forward position to verify the cables will not be strained, so the tray can lock into position without stress on the cables. After examining the cables, return the tray into the rack.
- \_\_\_ Step 12. Trim the cable tie ends flush to the head of the tie.
- \_\_\_ Step 13. To secure (lock) the 3570 library into the rack, refer to Figure 56 on page 78 and Figure 57 on page 80. Open the front door of the 3570 library. On the right and left sides are offset brackets. (You may have to adjust the brackets to locate the bracket hole to the captured nut **7**.) Place two socket head screws **2** through the bracket and into the M4 caged nut **7**. Tighten the screws.
- \_\_\_ Step 14. Now is the time to re-install the front door.



**CAUTION:**  
Installing the door requires two people.

To re-install the rack front door, have one person hold the door while the other installs the j-pins from top to bottom.

## Attaching SCSI and Power Cables to Model C22 (Dual-Drive Split-Host)



This section instructs you on the proper installation of electrical components. You must take care to read the safety instructions at the beginning of this manual (see "Safety Notices" on page xi) before you proceed.

For this option, you must have an additional Adaptec Card Kit Adapter PN08L6517.

- \_\_\_ Step 1. Ensure the rack power is off.
- \_\_\_ Step 2. Take the two types of power cords **19/20** and determine which one will seat into the rack power supply in the Netfinity Rack.

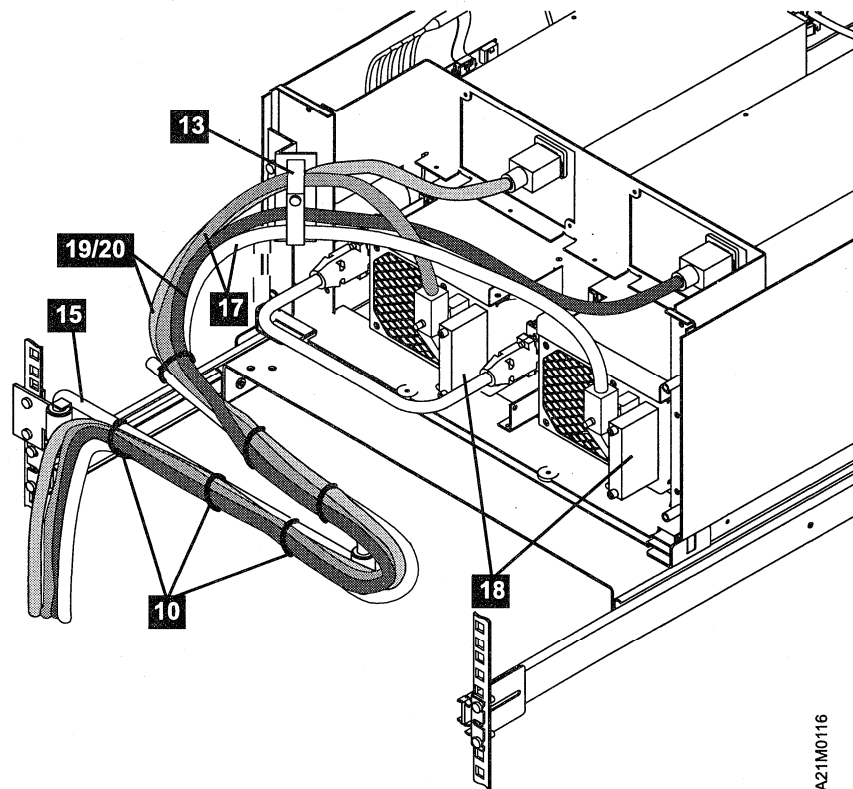

Figure 66. Model C22 (Dual-Drive Split-Host) Cable Routing

- \_\_\_ Step 3. Install the power cord **19/20** into the rear of the 3570 drive 1 plug (the left-most drive), route it through the upper wing of the clamp **13**, and let it hang there temporarily. Install the second power cord **19/20** into the rear of the 3570 drive 2 plug (the right-most drive), route it through the lower wing of the clamp **13**, and let it hang there temporarily.
- \_\_\_ Step 4. Install and finger-tighten the terminators **18** into the right-most sockets of each drive.
- \_\_\_ Step 5. Install the long SCSI host cable **17** into drive 1. Insert the right-angled plug into the left-most 68-pin socket (see Figure 66) so

the cable is looped upward. Next, install the second long SCSI host cable **17** into the left-most 68-pin socket of drive 2. Plug the right-angled plug into the left 68-pin socket (see Figure 66) so the cable is looped upward. Route it to the lower wing of the clamp (loop the cable so it does not extend above the top of the 3570 you are installing). With the power cord **19/20** and the SCSI cable **17** from drive 1 captured in the upper wing of the clamp, and the power cord **19/20** and the SCSI cable **17** from drive 2 captured in the lower wing of the clamp, tighten the screw.

- \_\_\_ Step 6. Install the RS422 cable (PN65F5399) **42**.
- \_\_\_ Step 7. See Figure 67. Push the 3570 completely forward so it will lock into position, then extend the articulated arm to its full length toward the 3570 library.

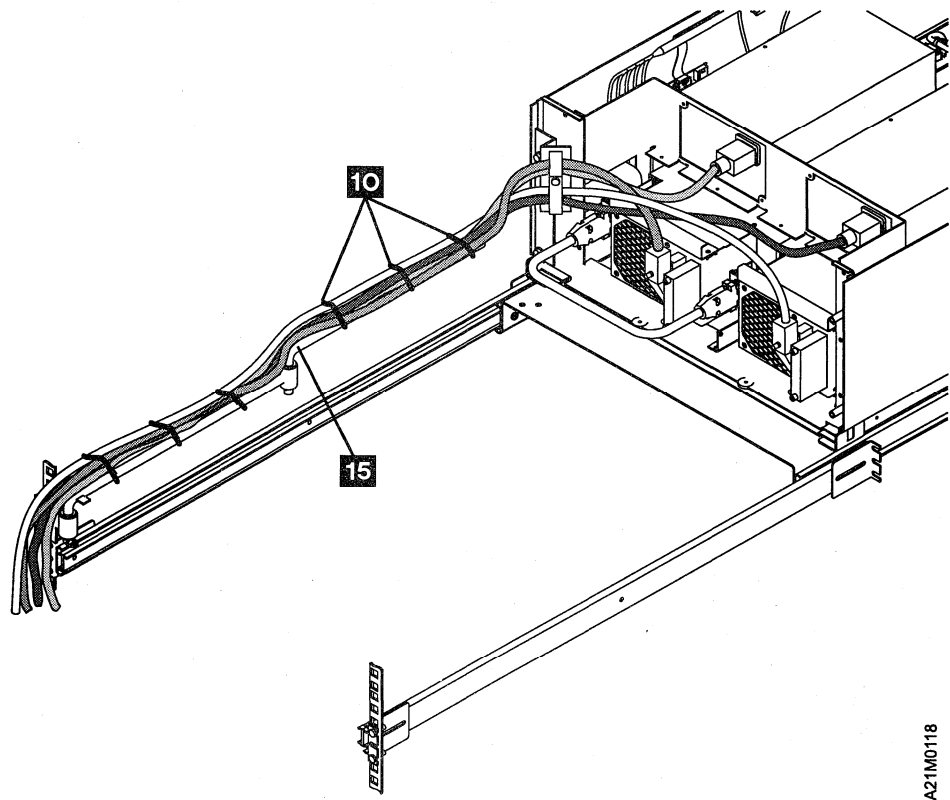

Figure 67. 3570 and Articulated Arm Extended for Model C22 Dual-Drive Dual-Host

**Note:** In the use of cable ties, note that the teeth of the ties are on the inside as you make the cable tie into a loop.

- \_\_\_ Step 8. Locate the cable ties **10** to the three flat sections on the articulated arm **15**. Avoid excessive cable loop between the library and the articulated arm. Firmly secure the cables to the forward arm section. The cable ties must be tight so they do not move as the articulated arm moves.
- \_\_\_ Step 9. Depress the tray security latch and bring the tray back into the rack area. With the articulated arm in an almost closed position, route the cables around the joint of the arm and secure the cables to the remaining arm length with cable ties. Tighten the cable ties.

- |
- |     \_\_\_ Step 10. Push the tray to its extreme forward position to verify the cables will
- |     not be strained, so the tray can lock into position without stress on the
- |     cables.
- |
- |     \_\_\_ Step 11. Trim the cable tie ends flush to the head of the tie.
- |
- |     \_\_\_ Step 12. To secure (lock) the 3570 library into the rack, refer to Figure 56 on
- |     page 78 and Figure 57 on page 80. Open the front door of the 3570
- |     library. On the right and left sides are offset brackets. (You may have
- |     to adjust the brackets to locate the bracket hole to the captured nut
- |     **7**.) Place two socket head screws **2** through the bracket and into
- |     the M4 caged nut **7**. Tighten the screws.
- |
- |     \_\_\_ Step 13. Now is the time to re-install the front door.



|

|     **CAUTION:**

|     **Installing the door requires two people.**

|

|     To re-install the rack front door, have one person hold the door while

|     the other installs the j-pins from top to bottom.

## Installation Checkout

### Verifying Operability of the Library Unit for Models C21 and C22

Figure 68 shows the front assembly for Models C21 and C22, refer to this figure for the following operating functions and perform the following steps in the order listed to ensure that the library transport mechanism is operating properly. See A, "Media/Hardware Problem Isolation" on page 165 to establish a criteria to determine whether there is a media or head problem present in your 3570 drive.

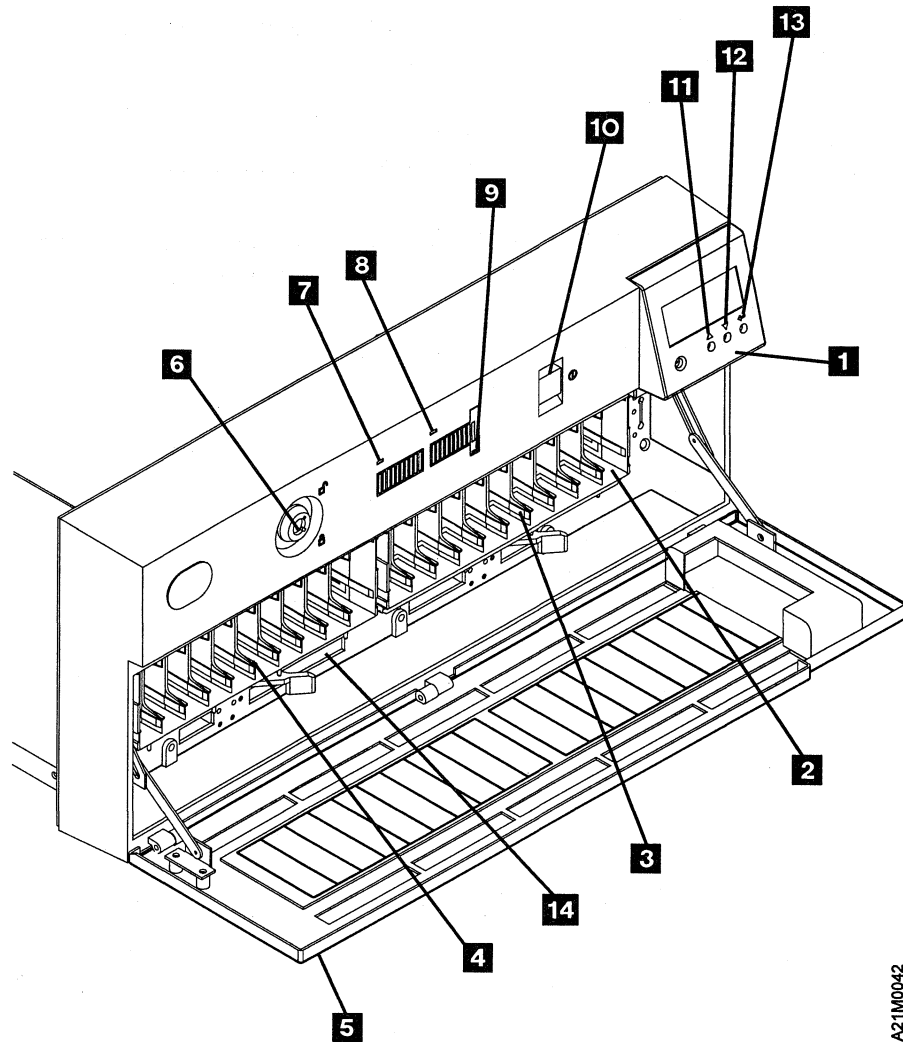

A21M0042

Figure 68. Front Assembly for Models C21 and C22

- |                                      |  |
|--------------------------------------|--|
| <b>1</b> Operator Panel              | <b>8</b> Magazine 1 In Use Indicator                   |
| <b>2</b> Priority Cell               | <b>9</b> Priority Cell In Use Indicator                |
| <b>3</b> Magazine 1 Location         | <b>10</b> Power On/Off Switch                          |
| <b>4</b> Magazine 2 Location         | <b>11</b> ScrollUp                                     |
| <b>5</b> Door                        | <b>12</b> Scroll Down                                  |
| <b>6</b> Security Key Lock           | <b>13</b> Enter  |
| <b>7</b> Magazine 2 In Use Indicator | <b>14</b> Serial Number Location (above lever opening) |

- \_\_\_ **Step 1.** Ensure that the Power switch **10** is set to the Off position. The switch is off when it is in the out position and even with the front cover surface.
- \_\_\_ **Step 2.** Use the keys that were taped to the back of the 3570 library.
- \_\_\_ **Step 3.** Unlock the library door **5** if it is locked.
- \_\_\_ **Step 4.** Open the library door **5** by pressing the raised ribs on the top center of the door.
- \_\_\_ **Step 5.** Before turning on power, the orange stopper (see **1** in Figure 69) must be removed from the unit. The stopper is pressed on the rail to prevent the picker from moving during shipping. Do the following to remove the stopper:
  - a. Open the door and remove the tape from the magazine lock levers.
  - b. Look inside the unit and find the orange tag (see **2** in Figure 35 on page 50) that is attached to the stopper. The orange tag will assist you in finding the orange stopper.
  - c. **Do not pull on the string or the tag to remove the stopper.** Reach inside the unit and pull the orange stopper off the rail using your finger.
  - d. Save the stopper with the packaging material for later reshipment or relocation.

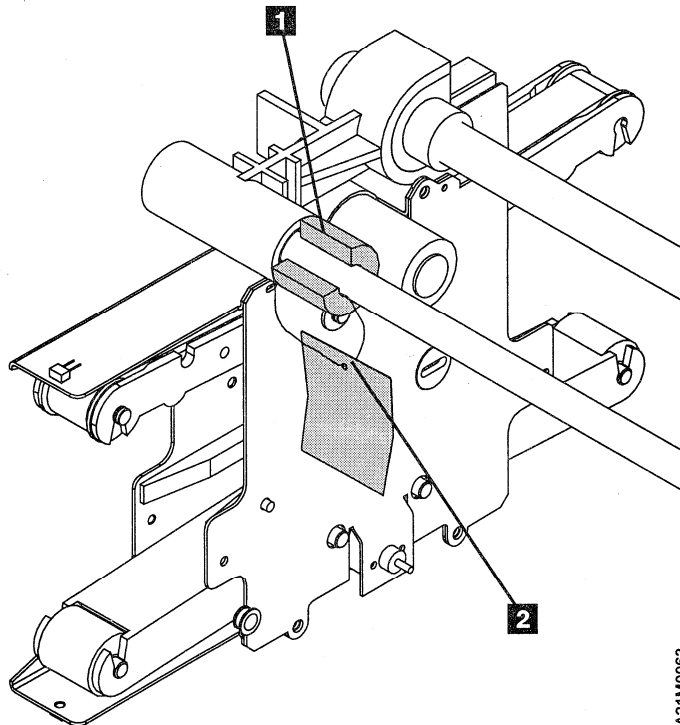

A21M0063

Figure 69. Orange Picker Stopper

- \_\_\_ **Step 6.** To install the magazines, see “Inserting or Removing a Magazine” on page 126.
- \_\_\_ **Step 7.** Move the magazine lock levers to the magazine lock position.



\_\_\_ **Step 8.** Close the door.



\_\_\_ **Step 9.** Plug the library power cord into the rack power supply and turn on the rack power supply.

\_\_\_ **Step 10.** Press the Power switch **10** to the On position.

\_\_\_ **Step 11.** Monitor the LED indicators **7**, **8**, and **9**. They will remain flashing until the power-on self-test is completed, and then they will shut off. This power-on self-test lasts about 2.5 minutes. During the power-on cycle, you will see a message DIAGNOSTIC RUN. If the power-on self-test diagnostics detect a problem, a FRU identifier (field-replaceable unit identifier or FID) is posted on the operator panel. If an error occurs, you may be able to correct the error. See "Resolving ATTENTION Messages" on page 142 for specific actions to take. If you are unable to correct the error, note the FID and contact your service representative. Wait until the LED indicators are off before proceeding.

**Note:** If you forgot to remove the shipping bracket, a FID1 95 notice will be posted. Turn the power switches off and return to step 1 on page 96.

\_\_\_ **Step 12.** If you are verifying the operation of Magstar MP Model C22, skip to step 20 on page 98.

#### **Model C21 Load/Unload Cartridge to/from drive**

\_\_\_ **Step 13.** At power on, the Status screen will be displayed, press the Enter button **13** to display the **OPTIONS** menu.

\_\_\_ **Step 14.** See Figure 68 on page 95. Select SET LIBR MODE from the **OPTIONS** menu by using the Scroll Down button **12** and the Scroll Up button **11** to move the arrow (>) to the selection, and then press the Enter button **13**.

**Note:** Use the Scroll buttons and the Enter button in a similar manner whenever you select an option from a menu. It may be necessary to select CANCEL to return to the previous menu.

\_\_\_ **Step 15.** Select manual mode of operation by performing the following steps at the operator panel:

a. Scroll Down, select MANUAL from the Set Library Mode Menu and press the Enter button. This selection will return you to the **OPTIONS** menu.

b. Select SHOW STATUS to display the mode of operation.

At this point, the operator panel will display **M** at the start of line 2.

\_\_\_ **Step 16.** Load a scratch cartridge through the priority cell (see **1** in Figure 70 on page 98) to the import position by pushing it gently into the priority cell until it comes to a stop and even with the front of the magazine. Select START from the main **OPTIONS** menu.

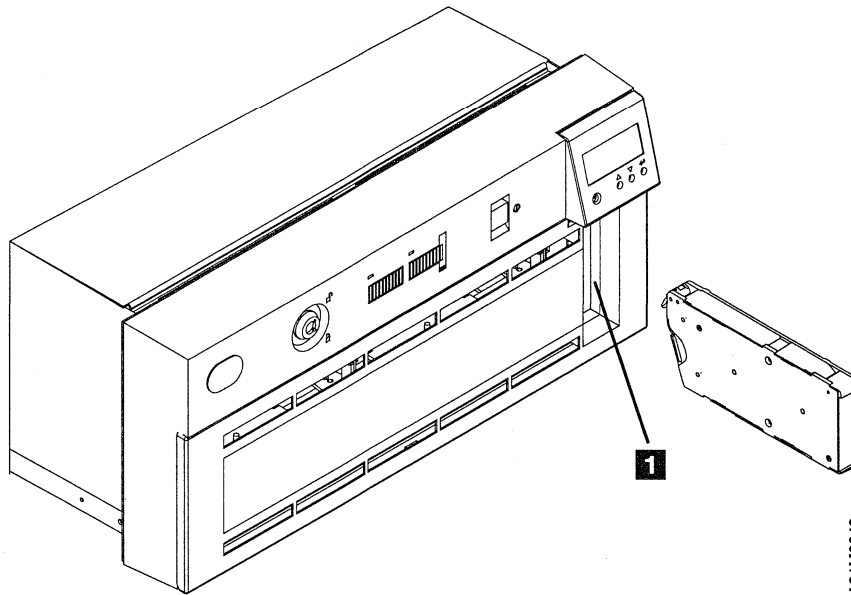

Figure 70. Location of Priority Cell in Models C21 and C22

- \_\_\_ **Step 17.** Verify the library is operating properly by observing the LOAD PT message on line 1 of the display. See “Resolving ATTENTION Messages” on page 142 if this message is not displayed.
- \_\_\_ **Step 18.** Select UNLOAD DRIVE from the **OPTIONS** menu and ensure the cartridge comes out of the priority cell. See “Removing a Stuck Cartridge” on page 129 if the cartridge does not unload properly.
- \_\_\_ **Step 19.** Proceed to “Setting the SCSI Address and Configuring the Library for Models C21 and C22” on page 101.

### Model C22

The following steps, as they pertain to a Model C22, verify that the second drive, drive 2, is fully tested. In order to test both drives, you must temporarily configure the library to split mode. Base mode only allows you to test drive 1.

- \_\_\_ **Step 20.** The library configuration of BAS or SPL is displayed on line 3 of the operator panel display. (Refer to item **16** in Figure 86 on page 137.) If the operator panel indicates Split Configuration (SPL) on line 3 of the display, continue with step 34 on page 99; otherwise continue with the next step.
- \_\_\_ **Step 21.** Press the Enter button to display the **OPTIONS MENU**.
- \_\_\_ **Step 22.** Select EDIT CONFIG from the **OPTIONS** menu by using the Scroll Down button **12** and the Scroll Up button **11**; then move the arrow (>) to the selection and press the Enter button **13**. See Figure 68 on page 95.
- \_\_\_ **Step 23.** Select SET LIBR CONFIG from the **Edit Configuration Menu** and press Enter.
- \_\_\_ **Step 24.** Use the Scroll Down button to move the arrow to the line indicating SPLIT, and press Enter.
- \_\_\_ **Step 25.** After SPLIT configuration is chosen, select CANCEL and press the Enter button to return to the **Edit Configuration Menu**.

- \_\_\_ **Step 26.** Select CANCEL and press Enter again. The **Unload and Reset Menu** will appear.
- \_\_\_ **Step 27.** Determine whether there is a cartridge in the drive by looking at the display, there should be no loaded cartridges. Line 2 pertains to drive 1; line 3 pertains to drive 2:
- If \*UNLOAD DRIVE is displayed, no cartridge is in the drive.
  - If UNLOAD DRIVE (without an asterisk) is displayed, a cartridge is in the drive.
- \_\_\_ **Step 28.** Select UNLOAD DRIVE if a cartridge is loaded in drive 1 or drive 2; otherwise skip to step 32.
- \_\_\_ **Step 29.** Select the drive number to be unloaded and press Enter. The cartridge will be unloaded from the drive and the status screen will be displayed. Press Enter to return to the **Drive Selection Menu**.
- \_\_\_ **Step 30.** Repeat step 29 until there are no cartridges loaded in drives 1 or 2. Then select CANCEL and press Enter to return to the **Unload and Reset Menu**.
- \_\_\_ **Step 31.** The 3570 will reset, run power-on diagnostics, and check the magazine cells to determine if cartridges are present. The reset is complete when all movement in the library has stopped and the hourglass symbols for each of the magazine cells has been replaced with a solid block, an open block, or a dash. When the reset is complete, press Enter to return to the Options Menu.
- \_\_\_ **Step 32.** Select RESET DRIVE and press Enter, then select PROCEED and press Enter.
- \_\_\_ **Step 33.** The 3570 will reset and the status screen will be displayed.
- \_\_\_ **Step 34.** Press the Enter button to display the **OPTIONS** menu
- \_\_\_ **Step 35.** See Figure 68 on page 95. Select SET LIBR MODE from the **OPTIONS** menu by using the Scroll Down button **12** and the Scroll Up button **11** to move the arrow (>) to the selection, and then press the Enter button **13**.
- Note:** Use the Scroll buttons and the Enter button in a similar manner whenever you select an option from a menu. In many cases, you may need to select CANCEL to return to the previous menu.
- \_\_\_ **Step 36.** Move the arrow to point to DRIVE 1, and press Enter.
- a. Scroll Down and select MANUAL.
  - b. After pressing Enter, the **SET LIBRARY MODE** menu is displayed.
- \_\_\_ **Step 37.** Move the arrow to point to DRIVE 2, and press Enter.
- a. Scroll Down and select MANUAL.
  - b. After pressing Enter, the **SET LIBRARY MODE** menu is displayed.
- \_\_\_ **Step 38.** Select CANCEL to return to **OPTIONS** menu.

- \_\_\_ **Step 39.** Select SHOW STATUS to display the Status screen. The operator panel should display M at the start of line 2, and M at the start of line 3, indicating Manual Mode for both tape drives.
- \_\_\_ **Step 40.** Press Enter to change from the Status screen to the **OPTIONS** menu.
- \_\_\_ **Step 41.** Load a media cartridge through the priority cell (see Figure 70 on page 98) to the import position by pushing it gently into the priority cell until it comes to a stop, and even with the front of the magazine.
- \_\_\_ **Step 42.** Select START from the **OPTIONS** menu.
- \_\_\_ **Step 43.** Select DRIVE 1 from the **START** menu.
- \_\_\_ **Step 44.** Verify the library is operating by observing the LOAD PT message on line 1 of the display. See “Resolving ATTENTION Messages” on page 142 if this message is not displayed.
- \_\_\_ **Step 45.** Press Enter to change from the Status screen to the **OPTIONS** menu.
- \_\_\_ **Step 46.** Scroll down and select UNLOAD DRIVE from the **OPTIONS** menu.
- \_\_\_ **Step 47.** Select DRIVE 1 from the **UNLOAD DRIVE** menu. Ensure the cartridge comes out of the priority cell. See “Removing a Stuck Cartridge” on page 129 if the cartridge does not unload properly.
- \_\_\_ **Step 48.** Open the library door, load a media cartridge into any cell of magazine 2 (the leftmost magazine), and close the library door. Refer to “Unloading or Loading a Cartridge in a Library Magazine” on page 128 for the procedure.
- \_\_\_ **Step 49.** When the library door has been closed, and all magazine cells have been checked for cartridges present, press Enter to change from the Status screen to the **OPTIONS** menu.
- \_\_\_ **Step 50.** Select START from the **OPTIONS** menu.
- \_\_\_ **Step 51.** Select DRIVE 2 from the **START** menu.
- \_\_\_ **Step 52.** Verify the library is operating properly by observing the LOAD PT message on line 4 of the display. See “Resolving ATTENTION Messages” on page 142 if this message is not displayed.
- \_\_\_ **Step 53.** Press Enter to change from the Status screen to the **OPTIONS** menu.
- \_\_\_ **Step 54.** Scroll down and select UNLOAD DRIVE from the **OPTIONS** menu.
- \_\_\_ **Step 55.** Select DRIVE 2 from the **UNLOAD DRIVE** menu. Ensure the cartridge is unloaded into the magazine cell. See “Removing a Stuck Cartridge” on page 129 if the cartridge does not unload properly.
- \_\_\_ **Step 56.** Remove the media cartridge from the cell in magazine 2 and close the library door. Refer to “Unloading or Loading a Cartridge in a Library Magazine” on page 128 for the procedure.
- \_\_\_ **Step 57.** This completes the required second drive (split-mode) test.
- \_\_\_ **Step 58.** Proceed to “Setting the SCSI Address and Configuring the Library for Models C21 and C22” on page 101.

## Setting the SCSI Address and Configuring the Library for Models C21 and C22

The settings and configuration information selected in this procedure are saved in non-volatile memory and become the default settings after subsequent power-on cycles.

### Note:

- Model C21 must be configured in base mode.
- Model C22 can be configured in either base mode or split mode.

This section describes how to:

- Select the language used by the menus at step 2 of the following list.
- Load the cleaning cartridge as defined in step 5 below.
- Select the library configuration from the following list at step 6.
- Set the SCSI address(es) in step 12 on page 102 for Model C22 and in step 14 on page 102 for Model C21.
- Select the library mode of operation at step 20 on page 102 for Model C22 and in step 30 on page 103 for Model C21.

Perform the following steps in the order indicated:

1. At power on, the Status screen will be displayed. Press the Enter button to display the OPTIONS menu.

### Language Selection

2. If a language for the menus other than English is desired, scroll down to SERVICES from the OPTIONS menu and press Enter. Select drive 1 and press ENTER, then select CHANG LANG and press ENTER
3. When the CHANG LANG menu appears, select English, Spanish, or German for the menus on the operator screen and press ENTER.
4. Scroll up to select CANCEL, and press ENTER. This completes your language selection.

### Storing Cleaning Cartridge

5. Select CLEAN from the OPTIONS menu and press ENTER. When the Clean Menu appears, select INSRT CLN TAP and press ENTER. If there is not a cleaning cartridge in the Priority Cell, a message will appear prompting the operator to PUT CLEANER CASSETTE IN PRIORITY CELL PRESS ENTER. After a cleaning cartridge is put in the Priority Cell and the Enter button is pressed, the cleaning cartridge will be loaded into the 3570 and stored in the internal cleaning cartridge storage cell. Select CANCEL and press ENTER to return to the OPTIONS menu. Your cleaning cartridge is now stored.
6. Select EDIT CONFIG from the OPTIONS menu and press ENTER.
7. If a Magstar MP 3570 Tape Subsystem Model C21 is being installed, skip to step 14 on page 102.

### Model C22 Split/Base Configuration

8. Select SET LIB CONFIG from the EDIT CONFIG menu and press ENTER.
9. An asterisk (\*) in front of BASE or SPLIT indicates the configuration that is currently selected. To keep the current configuration, select CANCEL and

press Enter. To change the configuration, move the arrow to select the desired configuration (BAS or SPL) and press ENTER; then Select CANCEL and press ENTER to return to the EDIT CONFIG menu.

- \_\_\_ 10. Press CANCEL at UNLOAD & RESET menu. Select RESET DRIVE and press ENTER. At ARE YOU SURE?, select PROCEED.

**Note:** The library will re-start itself with the newly selected configuration. This will take approximately two and one-half minutes.

See "Library Configurations" on page 117 for an explanation of the configuration.

#### **Set SCSI Address for Drive 2**

- \_\_\_ 11. Select EDIT CONFIG from the OPTIONS menu and press ENTER.
- \_\_\_ 12. Select ADDRESS DRV2 from the EDIT CONFIG menu and press ENTER.
- \_\_\_ 13. Select the SCSI address for tape drive 2 (the default address is set to 1) and press ENTER; then Select CANCEL and press ENTER to return to the EDIT CONFIG menu.

**Note:** The SCSI address for tape drive 2 should be different than the SCSI address for tape drive 1, or problems will be encountered. Select the SCSI address previously recorded by following the instructions and checklist in "Before You Begin" on page 42.

#### **Set SCSI Address for Models C21 and C22 Drive 1**

- \_\_\_ 14. Select ADDRESS DRV1 from the EDIT CONFIG and press ENTER.
- \_\_\_ 15. Select the SCSI address for tape drive 1 (the default address is set to 0) and press ENTER; then, Select CANCEL and press ENTER to return to the EDIT CONFIG menu.

**Note:** Select the SCSI address previously recorded by following the instructions and checklist in "Before You Begin" on page 42.

#### **Cleaner Tape Options**

- \_\_\_ 16. Select AUTO CLEAN from the EDIT CONFIG menu and press ENTER.
- \_\_\_ 17. An asterisk (\*) in front of ENABLE or DISABLE indicates if automatic cleaning is enabled or disabled. If the display shows \*ENABLE, the library unit will automatically clean the tape drive(s) when they require cleaning. If the display shows \*DISABLE, the operator must take action to clean the tape drive(s) when cleaning is required.

The default setting is automatic cleaning enabled. It is recommended to remain in this mode. To keep the current configuration, select CANCEL and press ENTER. To change the configuration, move the arrow to select the desired configuration (ENABLE or DISABLE) and press ENTER; then Select CANCEL and press ENTER to return to the EDIT CONFIG menu. the cleaner tape option is complete.

- \_\_\_ 18. Select CANCEL from the EDIT CONFIG menu and press ENTER.
- \_\_\_ 19. If a Model C21 is being installed, skip to step 29 on page 103.

#### **Model C22**

- \_\_\_ 20. Select UNLOAD DRIVE from the OPTIONS menu. ensure there is an (\*) in front of drive 1 and drive 2. If both drives have an asterisk, proceed to step 21 on page 103. Press CANCEL and get back to the OPTIONS menu. If

one or both drives does not have an asterisk, select that drive and unload the tape.

- \_\_\_ 21. Select SET LIBR MODE from the OPTIONS menu and press Enter.
- \_\_\_ 22. If the 3570 is configured to operate in split configuration, select DRIVE 1 and press ENTER, otherwise continue with the next step.
- \_\_\_ 23. Refer to "Library Modes of Operation" on page 115. Then, select the desired mode of operation (MANUAL, AUTOMATIC, or RANDOM) for tape drive 1 and press ENTER.  
**Note:** If the 3570 is configured to operate in Base Configuration, it is recommended to select the Random Mode of Operation. Drive 2 is not used when the 3570 is set in Base Configuration and Manual or Automatic modes of operation.
- \_\_\_ 24. If the 3570 is configured to operate in Base Configuration, continue with step 27.
- \_\_\_ 25. Select DRIVE 2 and press ENTER.
- \_\_\_ 26. Select the desired mode of operation (MANUAL, AUTOMATIC, or RANDOM) for tape drive 2 and press ENTER.
- \_\_\_ 27. Select CANCEL and press ENTER until the OPTIONS menu is reached.
- \_\_\_ 28. Continue at step 32.

#### **Model C21**

- \_\_\_ 29. Select UNLOAD DRIVE from the OPTIONS menu. ensure there is an (\*) in front of drive 1 and drive 2. If both drives have an asterisk, proceed to step 30. Press CANCEL and get back to the OPTIONS menu. If one or both drives does not have an asterisk, select that drive and unload the tape.
- \_\_\_ 30. Select SET LIBR MODE from the OPTIONS menu and press ENTER.
- \_\_\_ 31. Select the desired mode of operation (MANUAL, AUTOMATIC, or RANDOM) and press ENTER. (For additional information, see "Library Modes of Operation" on page 115.)

#### **Models C21 and C22**

- \_\_\_ 32. Press the Power switch (see **10** in Figure 68 on page 95) to the Off position.
- \_\_\_ 33. Continue with the Installing the Adaptec Adapter to the Host.

## Installing the Adaptec Adapter to the Host



This process requires you to be aware of your surroundings as regards electricity.

### Install the Adaptec Hardware

- \_\_\_ Step 1. Determine which host will be used.
- \_\_\_ Step 2. Open the Adaptec Adapter Kit and refer to *"Installing the Adaptec AHA-2944UW"* instructions.
- \_\_\_ Step 3. Follow the Adaptec install instructions, but read step 5 before you proceed.
- \_\_\_ Step 4. **Ensure you turn off the host power and unplug the host power cord.**
- \_\_\_ Step 5. When you complete installing the Adaptec AHA-2944UW host adapter, the instructions say to **not** replace covers. For **this 3570** installation, you are finished with the hardware install so you **do** cover the host. (This step is the same as the *"Reassembling the Computer"* step of the Adaptec information.
- \_\_\_ Step 6. This concludes the Adaptec procedures you are to follow.

### Verify the Adaptec Installation

- \_\_\_ Step 1. Plug in the host power, turn it on, and view the monitor screen. If the Adaptec AHA-2944UW hardware is installed properly, it will display the following message **C.1995 Adaptec Inc, All Rights Reserved.**
- \_\_\_ Step 2. If the message is not displayed, refer to the Adaptec instruction *"Need Assistance"*.
- \_\_\_ Step 3. Again, ensure it is safe to shut off the server and turn off the power.
- \_\_\_ Step 4. Take the SCSI cable plug you previously installed into the 3570 and install it into the Adaptec Adapter.
- \_\_\_ Step 5. Power on the library. It will go through its diagnostics. When it completes the diagnostics, you will see two horizontal lines on the liquid crystal display (LCD).
- \_\_\_ Step 6. Turn on the host power and let it boot up.
- \_\_\_ Step 7. The host monitor will read, in addition to the Adaptec AHA-2944UW and other information, the following.
  - For a Model C21, the screen will read **"SCSI #0 IBM 03570B21"**.
  - For a Model C22, the screen will read **"SCSI #0 IBM 03570B21"** and **"SCSI #1 IBM 03570B22"**.







- \_\_\_ Step r. At the RETURN TO CONTINUE prompt, key in **99** and click on enter.
- \_\_\_ Step s. Enter the number associated with Exit NTUTIL and press enter.
- \_\_\_ Step t. To close the DOS window, type exit and press enter.
- \_\_\_ Step u. **Important:** To avoid conflict with 3570 application device drivers that may be installed, it is necessary to ensure that the IBM Magstar changer driver and the IBM Magstar device driver be set to **Manual** or **Disabled** (manual is preferred) and that the status is **Not Started**. The following procedure instructs you how to perform this task.
  - 1) Click on Start.
  - 2) Click on Setting.
  - 3) Click on Control Panel.
  - 4) Click twice on Devices.
  - 5) Scroll down until the IBM Magstar drivers are visible.
  - 6) Click on the IBM Magstar changer driver to hi-light it. Ensure you hi-light *only* the IBM Magstar drivers.
  - 7) Click on the Startup push button.
  - 8) In the pop-up window, select the Manual radio button.
  - 9) Click on OK.
  - 10) A pop-up window with the following message will appear: *Changing the Startup Type for the "IBM Magstar device/changer driver" may leave the system in an unusable state. Do you want to make the change?*
  - 11) Click on Yes.
  - 12) Repeat steps 10u6 through 10u9 for the IBM Magstar device driver.
  - 13) Quit out of the window.
  - 14) Shutdown and restart the computer.
  - 15) Repeat steps 10u1 through 10u5 to verify that the status is blank (Not Started).

## Review and Additional SCSI Device Connections for Models C21 and C22

The host (initiator) SCSI port must be inactive before adding or removing any SCSI device. For Model C22 installation, see "Model C22 SCSI Cable Connections" on page 109.

### Model C21 SCSI Cable Connections

- 1. If the 3570 is the first or only SCSI device connected in line to the initiator, connect the SCSI cable coming from the initiator to the leftmost SCSI connector on the back of the library (see **1** in Figure 71).
- 2. If the 3570 is not the first device on the SCSI bus, connect the SCSI interface cable coming from the next closest device to the leftmost SCSI connector on the back of the library (see **1** in Figure 71).
- 3. If this is the last device on this SCSI bus, locate the SCSI interface terminator (P/N 61G8324) and attach it to the rightmost SCSI connector on the back of the library (see **2** in Figure 71).
- 4. If the library is not the last device on this SCSI bus, locate the SCSI interface cable to the next device and connect it to the unused, rightmost SCSI interface connector on the back of the library (see **2** in Figure 71).

**Note:** There are two SCSI connectors on the back of the 3570 library. When they are connected correctly, each of these connectors must have either a SCSI cable or a SCSI terminator attached.

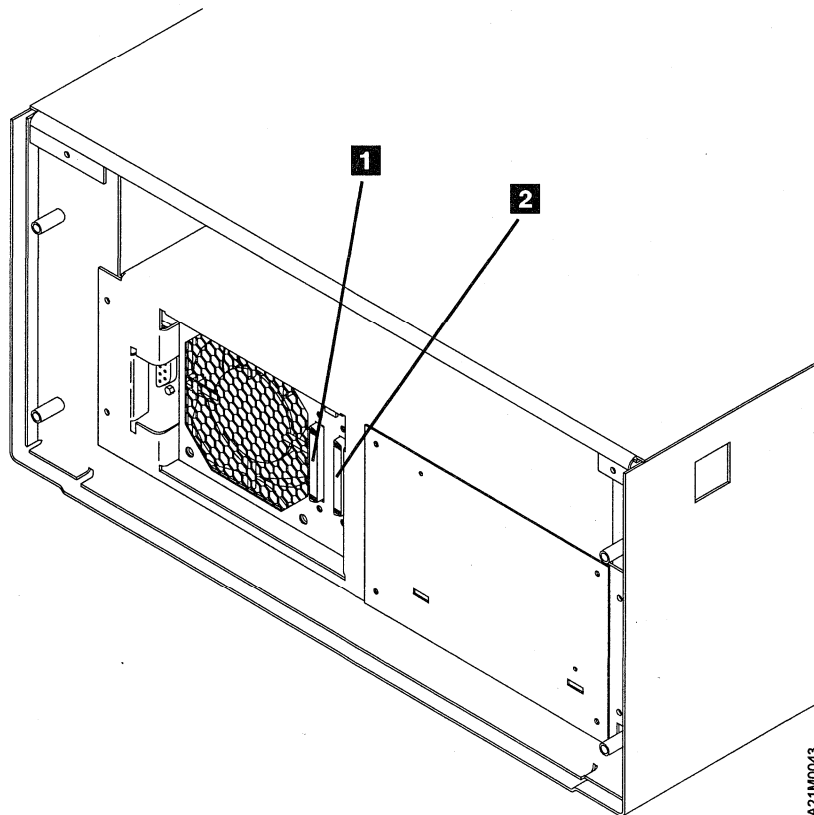

Figure 71. Rear View of Model C21

Figure 72 shows an example of a single 3570 attached to the host (initiator).

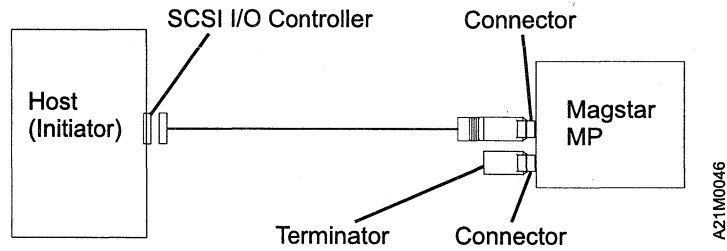

Figure 72. Example of Attaching One SCSI Device to the Host (Initiator)

Figure 73 shows an example of attaching multiple SCSI devices to a host.

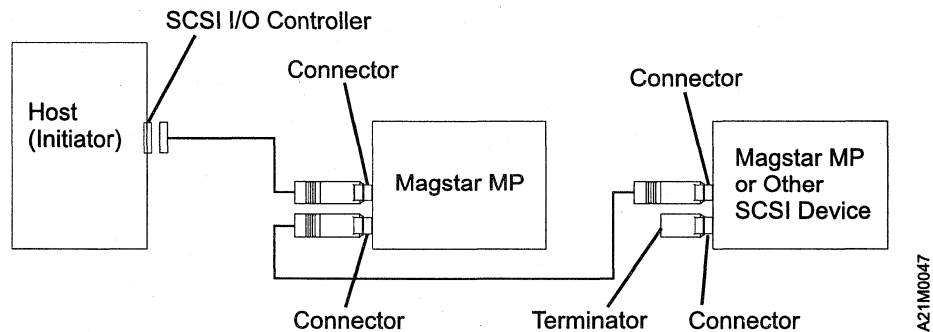

Figure 73. Example of Attaching Multiple SCSI Devices to the Host

### Model C22 SCSI Cable Connections

- 1. For a 3570 Split Configuration setup, continue at step 7 on page 110. For a 3570 Base Configuration setup, continue with the following step. (See "Library Configurations" on page 117 for information about base and split configurations.)

#### Base Configuration:

- 2. Ensure the SCSI Bus Jumper is connected to the rightmost SCSI connector on the back of tape drive 1, and to the leftmost SCSI connector on the back of tape drive 2. (See items **2** and **3** in Figure 74 on page 111).
- 3. If the 3570 is the first, or only, device in line connected to the initiator, connect the SCSI cable coming from the initiator to the leftmost SCSI connector on the back of the library. (See item **1** in Figure 74 on page 111).
- 4. If the 3570 is **not** the first device on the SCSI bus, connect the SCSI interface cable coming from the next closest device to the leftmost SCSI connector on the back of the library. (See item **1** in Figure 74 on page 111).

- \_\_\_ 5. If this is the last device on the SCSI bus, locate the SCSI interface terminator (P/N 61G8324) and attach it to the rightmost SCSI interface connector on the back of the library. (See item 4 in Figure 74 on page 111). If the library is **not** the last device on the SCSI bus, locate the SCSI interface cable to the next device, and connect it to the unused, rightmost SCSI interface connector on the back of the library. (See item 4 in Figure 74 on page 111).
- \_\_\_ 6. Continue at step 16 on page 111.  
**Split Configuration:**
- \_\_\_ 7. If a SCSI bus jumper is installed, remove it. See item 5 in Figure 76 on page 112.  
**Note:** If attaching to other types of hosts, the SCSI Bus Jumper may remain in place to connect both devices on a single SCSI bus.
- \_\_\_ 8. If tape drive 1 in the 3570 is the first, or only, device in line connected to the initiator, connect the SCSI cable coming from the initiator to the leftmost SCSI connector on the back of tape drive 1. (See item 1 in Figure 74 on page 111).
- \_\_\_ 9. If tape drive 1 is **not** the first device on the SCSI bus, connect the SCSI interface cable coming from the next closest device to the leftmost SCSI connector on the back of tape drive 1. (See item 1 in Figure 74 on page 111).
- \_\_\_ 10. If tape drive 1 is the last device on the SCSI bus, locate the SCSI interface terminator (P/N 61G8324) and attach it to the rightmost SCSI interface connector on the back of tape drive 1. (See item 2 in Figure 74 on page 111).
- \_\_\_ 11. If tape drive 1 is **not** the last device on the SCSI bus, locate the SCSI interface cable to the next device, and connect it to the unused, rightmost SCSI interface connector on the back of tape drive 1. (See item 2 in Figure 74 on page 111).
- \_\_\_ 12. If tape drive 2 in the 3570 is the first, or only, device in line connected to the initiator, connect the SCSI cable coming from the initiator to the leftmost SCSI connector on the back of tape drive 2. (See item 3 in Figure 74 on page 111).
- \_\_\_ 13. If tape drive 2 is **not** the first device on the SCSI bus, connect the SCSI interface cable coming from the next closest device to the leftmost SCSI connector on the back of tape drive 2. (See item 3 in Figure 74 on page 111).
- \_\_\_ 14. If tape drive 2 is the last device on the SCSI bus, locate the SCSI interface terminator (P/N 61G8324) and attach it to the rightmost SCSI interface connector on the back of tape drive 2. (See item 4 in Figure 74 on page 111).
- \_\_\_ 15. If tape drive 2 is **not** the last device on the SCSI bus, locate the SCSI interface cable to the next device, and connect it to the unused, rightmost SCSI interface connector on the back of tape drive 2. (See item 4 in Figure 74 on page 111).

16. When the 3570 is correctly connected, all four SCSI connectors on back of the Magstar MP (see **1**, **2**, **3**, and **4** in Figure 74) must have either a SCSI cable or a SCSI terminator attached.

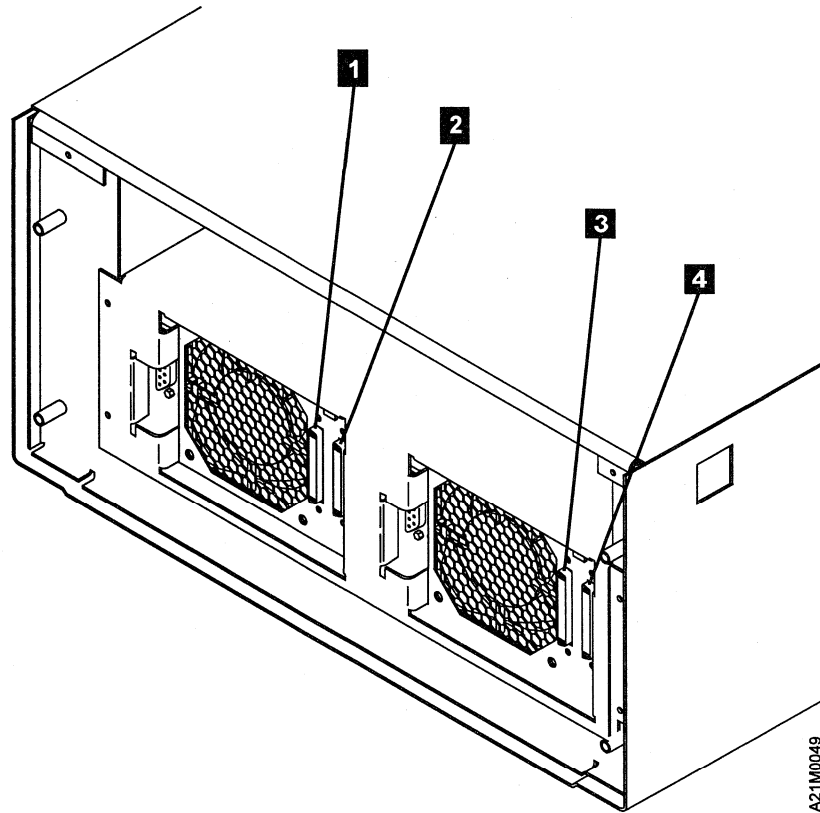

Figure 74. Rear View of Model C22

Figure 75 shows an example of a single 3570 Model C22 in Base Configuration attached to the host (initiator). Figure 76 shows an example of a single 3570 Model C22 in Base Configuration attached to the host (initiator) with multiple other SCSI devices.

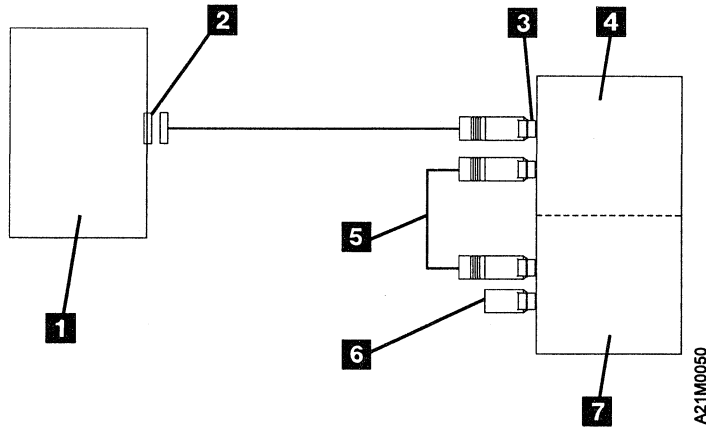

Figure 75. Example of Attaching One SCSI Device to the Host (Initiator)

**Note:** The 3570 Model C22 is in Base Configuration

- |                                  |                                  |
|----------------------------------|----------------------------------|
| <b>1</b> Host (Initiator)        | <b>5</b> SCSI Bus Jumper         |
| <b>2</b> SCSI I/O Controller     | <b>6</b> SCSI Terminator         |
| <b>3</b> SCSI Connector          | <b>7</b> Magstar MP Tape Drive 2 |
| <b>4</b> Magstar MP Tape Drive 1 |                                  |

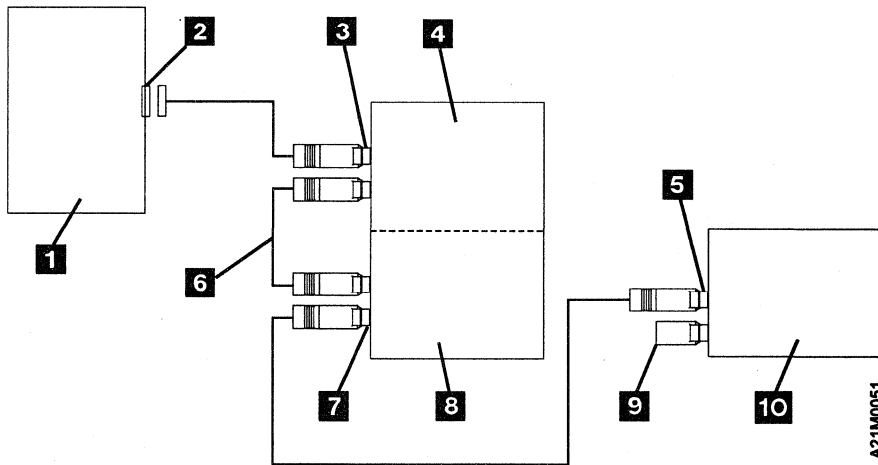

Figure 76. Example of Attaching Multiple SCSI Devices to a Host (Initiator)

**Note:** The Model C22 is in Base Configuration

- |                              |                                     |
|------------------------------|-------------------------------------|
| <b>1</b> Host (Initiator)    | <b>6</b> SCSI Bus Jumper            |
| <b>2</b> SCSI I/O Controller | <b>7</b> SCSI Connector             |
| <b>3</b> SCSI Connector      | <b>8</b> Tape Drive 2               |
| <b>4</b> Tape Drive 1        | <b>9</b> SCSI Terminator            |
| <b>5</b> SCSI Connector      | <b>10</b> 3570 or Other SCSI Device |



Figure 77 shows an example of a single Model C22 in Split Configuration. Tape drive 1 **4** is a single SCSI device attached to the first host (initiator). Tape drive 2 **8** is attached to the second host (initiator) with multiple other SCSI devices.

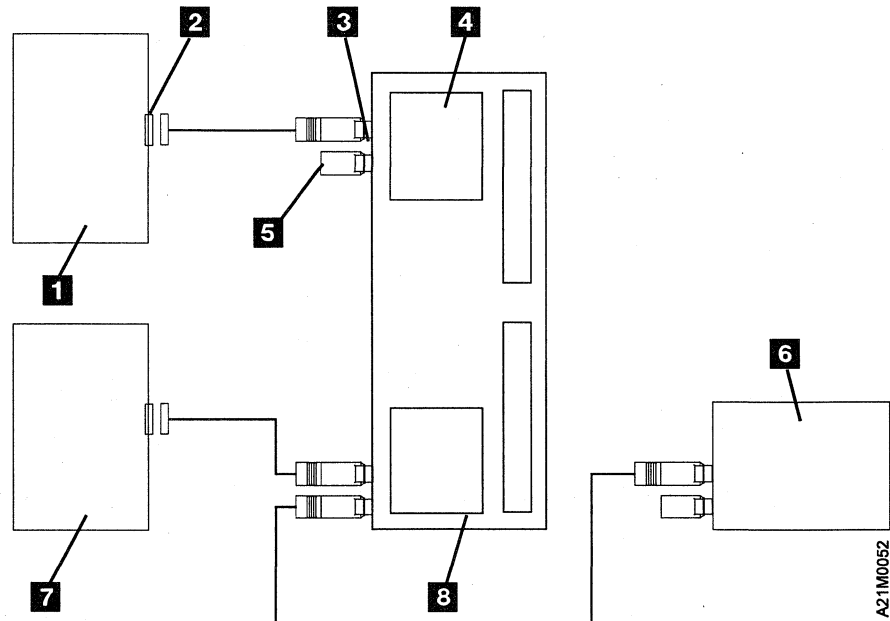

Figure 77. Attaching Model C22 In Split Configuration

- |                              |                                    |
|------------------------------|------------------------------------|
| <b>1</b> Host (Initiator)    | <b>5</b> SCSI Terminator           |
| <b>2</b> SCSI I/O Controller | <b>6</b> 3570 or Other SCSI Device |
| <b>3</b> SCSI Connector      | <b>7</b> Host (Initiator)          |
| <b>4</b> Tape Drive 1        | <b>8</b> Tape Drive 2              |

## Removing or Relocating Models C21 and C22

If an installed 3570 subsystem must be either disconnected or relocated to a different system, perform the following steps in the order shown:

- 1. If your host initiator has software aids for system upgrades, installations, or relocations, execute that software and follow the instructions provided with the software.
- 2. Ensure that all tape cartridges have been removed from all drives.
- 3. To remove the cleaner cartridge from the cleaner cartridge storage cell inside the housing of the subsystem, select the Remove Cleaner Tape option from the **Clean** menu. The library will automatically put the cleaner cartridge into the export position of the priority cell where the operator can remove it.
- 4. If the 3570 is being moved, turn off the power and disconnect host cables, if necessary.



---

## Chapter 9. Operating the Library

This section describes the modes of operation, operating procedures, and operator menus for the library models.

---

### Library Modes of Operation

The library processes cartridges either sequentially or non-sequentially under direction of the host. For sequential processing, the library is capable of operating in either automatic or manual modes, selectable at the operator panel. These two modes are identical except that following each unload operation in manual mode, the operator must push a button to initiate the next load operation.

In order to process cartridges in a non-sequential manner, the library must be set to random mode at the operator panel.

The mode selected by the operator is stored in non-volatile memory and becomes the default mode during subsequent power-on cycles.

**Note:** When using ADSM with a Magstar MP dual-drive library, it is recommended the Magstar MP be configured to operate in Random Mode and Base Configuration. This allows ADSM to use the second drive for reclamation.

### Random Mode

Random mode allows the Magstar MP to act as a self-contained library of up to 19 cartridges, controlled entirely by SCSI hosts. In addition, access is provided to a 20th cartridge through the priority cell. The host uses SCSI commands to a Medium Changer device to select a cartridge from a source element and move it to its destination element. Control of the source and destination elements is left entirely to the host.

A request for an external cartridge to be mounted can be satisfied by inserting the cartridge into the priority cell in the import position. The Magstar MP notifies hosts of the presence of a cartridge in the priority cell, but the host must specifically address that cell to access the cartridge.

When the destination of a move is a magazine cell, the transport mechanism places the cartridge in the cell in the import position for possible later re-use. However, if the destination is the priority cell, the transport mechanism places the cartridge in the cell in the export position.

Because the library door must be closed while in random mode, the priority cell is used as an import/export station to add or remove cartridges from the library without violating the integrity of the magazine inventory. A host can cause cartridges from the priority cell to be moved to any empty magazine cell or to a device. It can also cause cartridges from a magazine or a device to be moved to the priority cell. Requests for external cartridges to be mounted can only be satisfied when magazine 1 (the rightmost magazine) is present. Library inventory and control is entirely the responsibility of the hosts. If the library door is opened while in random mode, the drive responds to the next command with a Unit Attention condition.

## Automatic (Sequential) Mode

Automatic mode provides the customer the ability to operate the library as a sequential autoloader, keeping the tape drive continually fed with cartridges. The host (initiator) controls only the unload of a cartridge from the tape drive. The library will automatically load the next available cartridge into the drive after the ejected cartridge is put back into the magazine. All media changer operations are effectively hidden from the system.

When automatic mode is selected, the cartridges are automatically processed according to their positions in the magazines. The library processes all cartridges that are in import positions sequentially, beginning at the rightmost cell position and then proceeding from right to left as viewed from the front of the library.

After processing a cartridge, the library returns it to its original magazine cell and places it in the export position.

The operator can supply external cartridges to an application by inserting a cartridge in the priority cell in the import position. Any cartridge inserted in the priority cell will automatically be the next cartridge loaded into the drive. When that specific cartridge is unloaded, the library returns the cartridge to the priority cell in the export position and resumes processing cartridges from the magazine. The library continues to search for cartridges until it has searched all cells without finding a cartridge in the import position.

The operator can remove cartridges that are in the export position from magazines and add cartridges in the import position to the magazine while the library is in automatic mode. The library stops when the door is opened. When the door is closed, the library resumes operation where it left off. If a cartridge is in a drive when the door is opened, processing continues until complete. When the door is closed, the cartridge is returned to the cell from which it was removed.

An operator may also insert full magazines into the library when it is in automatic mode.

If the operator unloads a cartridge from the tape drive by using the operator panel on the Magstar MP 3570 Tape Subsystem, the operator must select START on the operator panel to load the next cartridge. If the cartridge is unloaded from the tape drive by the host, the next cartridge is automatically loaded in the tape drive. There is no need for the operator to select START on the operator panel.

## Manual (Sequential) Mode

In manual mode, the library functions the same as in the automatic mode, except the operator initiates each load operation. Each time the operator selects START from the Options Menu, the library selects the cartridge from the next unprocessed magazine cell and mounts it in the drive. Manual mode operation is also activated by placing a cartridge in the import position of the priority cell and selecting START. Only one cartridge is processed for each operator action. After being unloaded, each cartridge is returned to the magazine location from which it was taken and placed in the export position.

The library starts processing cartridges beginning at the rightmost cell in the library. The search for unprocessed cartridges is from right to left across the magazine(s) as viewed from the front of the library.

---

## Library Configurations

Dual-drive libraries may operate in Base Configuration or Split Configuration as selected in the operator menus. Single-drive libraries do not support Split Configuration.

### Notes:

1. If attached to an AS/400 system, when switching between Base and Split configuration, the I/O processor must be reloaded. To reload the I/O processor, vary off and on with reset, or use STRSST to IPL the I/O processor.
2. If the Magstar MP dual-drive library is in Split Configuration, microcode update is not supported using the PTF process. The service representative must update the Magstar MP using an FMR tape according to the instructions in the maintenance information manual.

## Base Configuration Modes of Operation

In a Base Configuration, all magazine cells are accessible to all hosts (initiators) on the bus. This is the default configuration for all library models. The library mode of operation is selected at the operator panel for drive 1 only, but it applies to the entire library.

### Random Mode - Base Configuration

See "Random Mode" on page 115 for an overview of this mode. Magstar MP acts as a self-contained library of up to 19 cartridges with additional access to a 20th cartridge through the priority cell. In models with 2 drives, the source and destination elements of a move can indicate either drive. (Both drives can be used.) See "SCSI Medium Changer Addressing for Base and Split Configurations" on page 119.

### Automatic Mode - Base Configuration

See "Automatic (Sequential) Mode" on page 116 for an overview of this mode. In models with 2 drives, only drive 1 is used for this mode. Drive 2 is unused. The library processes all cartridges that are in import positions sequentially, beginning at the rightmost priority cell position, then proceeding from right to left across both magazines as viewed from the library front.

### Manual Mode - Base Configuration

See "Manual (Sequential) Mode" on page 116 for an overview of this mode. In models with 2 drives, only drive 1 is used for this mode. Drive 2 is unused. The library processes all cartridges that are in import positions sequentially, beginning at the rightmost priority cell position, then proceeding from right to left across both magazines as viewed from the library front.

## Split Configuration Modes of Operation

It is advantageous to be able to share a single library between host systems. Unfortunately, some applications (and some systems) do not allow for sharing devices between systems. Split Configuration allows for a single library to be used by multiple systems by having the library manage this 'sharing'. This is accomplished by having the library appear as two separate half-size libraries on one or two SCSI busses. Two SCSI busses are created when the SCSI Bus Jumper is removed between the drive 1 and drive 2 SCSI ports.

Split Configuration is created by logically dividing one physical library into two logical libraries.

Logical Library 1 consists of :

- Drive 1,
- Magazine 1 (including the priority cell), and
- The transport mechanism.

Logical Library 2 consists of :

- Drive 2,
- Magazine 2, and
- The transport mechanism.

Logical Library 1 is available to host systems via the drive 1 SCSI port, Logical Library 2 is available to host systems via the drive 2 SCSI port. Cartridges not in the logical library associated with a port are not accessible to commands received on that port.

In a Split Configuration, the library mode of operation is selected separately for drive 1 (Logical Library 1) and drive 2 (Logical Library 2). All possible combinations of modes of operation are allowed in Split Configuration.

### Random Mode - Split Configuration

See "Random Mode" on page 115 for an overview of this mode. All operations for the priority cell are associated with the Logical Library 1 only. For the Logical Library 1, Magstar MP acts as a self-contained library of up to 9 cartridges with additional access to a 10th cartridge through the priority cell. For the Logical Library 2, the Magstar MP acts as a self-contained library of up to 10 cartridges, with no host access to the priority cell. See "SCSI Medium Changer Addressing for Base and Split Configurations" on page 119.

### Automatic Mode - Split Configuration

See "Automatic (Sequential) Mode" on page 116 for an overview of this mode. All operations for the priority cell are associated with the Logical Library 1 only. For the Logical Library 1, the operation begins at the rightmost priority cell position, then proceeds from right to left across magazine 1. For the Logical Library 2, the operation begins at the rightmost cell in magazine 2, then proceeds from right to left across magazine 2.

### **Manual Mode - Split Configuration**

See "Manual (Sequential) Mode" on page 116 for an overview of this mode. All operations for the priority cell are associated with the Logical Library 1 only. For the Logical Library 1, the operation begins at the rightmost priority cell position, then proceeds from right to left across magazine 1. For the Logical Library 2, the operation begins at the rightmost cell in magazine 2, then proceeds from right to left across magazine 2.

## **SCSI Medium Changer Addressing for Base and Split Configurations**

Magstar MP library models are consistent with the SCSI standard for Sequential Access and Medium Changer devices. Each tape drive in a Magstar MP library control interface consists of a SCSI Medium Changer device available as a logical unit through one or both drive ports, depending on the library configuration.

For a Base Configuration, a Medium Changer device is available through the drive 1 SCSI port only.

For Split Configuration, the transport mechanism is shared, but it appears as two Medium Changer devices, one for each drive SCSI port.

## Mapping Element Addresses to Physical Locations

Each physical location capable of holding a tape cartridge is assigned an element address value. The physical cartridge locations and their element address values are shown in Figure 78. (Figure 78 is a top view of the library with the back at the top of the figure.)

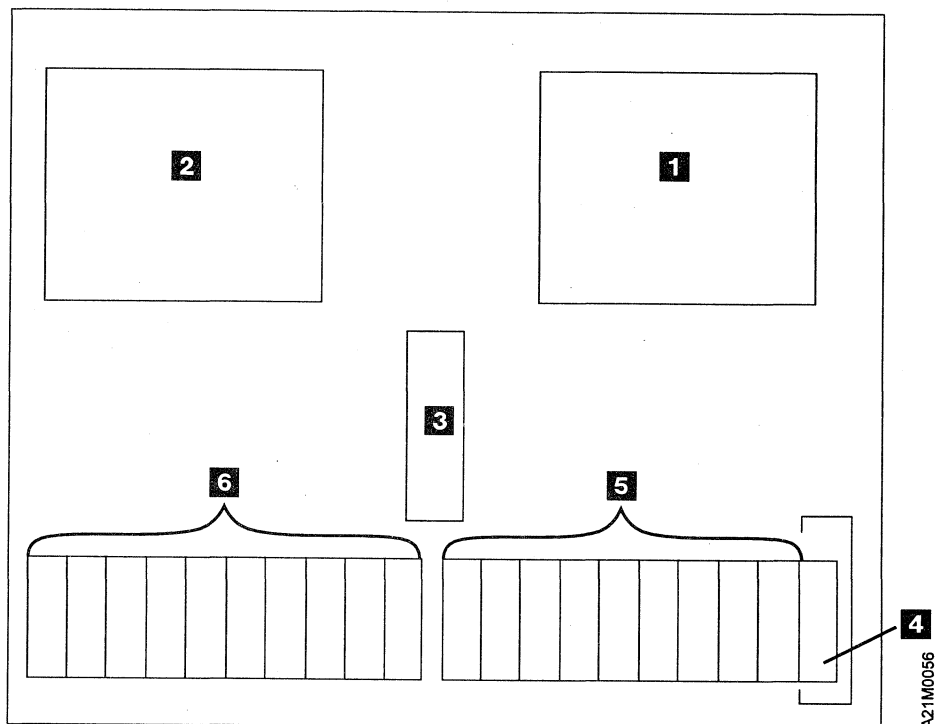

Figure 78. Magstar MP Element Address

1. **1** Drive 1 (Data Transfer, Element Address 16)
2. **2** Drive 1 (Data Transfer, Element Address 17)
3. **3** Transport Mechanism (Medium Transport, Element Address 0)
4. **4** Priority Cell (Import/Export, Element Address 31)
5. **5** Magazine 1 excluding Priority Cell (Storage, Element Addresses 32-40 from right to left)
6. **6** Magazine 2 excluding Priority Cell (Storage, Element Addresses 41-50 from right to left)

The SCSI-2 model assumes each physical component has one unique element address and that all elements are visible to all hosts. SCSI-2 does not directly discuss library segmentation which occurs in a Split Configuration. Segmentation results in a subset of the library physical components becoming unavailable to a host. To handle library segmentation, the following rules apply:

- The element address mapping is unchanged for a Split Configuration.
- If a physical component is unavailable to a host because of Split Library configuration, the element address associated with that physical component is also unavailable as reflected in Mode Page X'1D' (Element Address Assignment) and in the response to a Read Element Status command.



- Mode Page X'1F' (Device Capabilities) is unchanged for a Split Configuration.
- For a Move Medium command or Reserve command, the elements which are unavailable are treated as invalid element addresses. Any attempt to access or reserve an unavailable element results in a CHECK CONDITION status.

## Front Panel Overview

Figure 79 shows the front assembly for the library models.

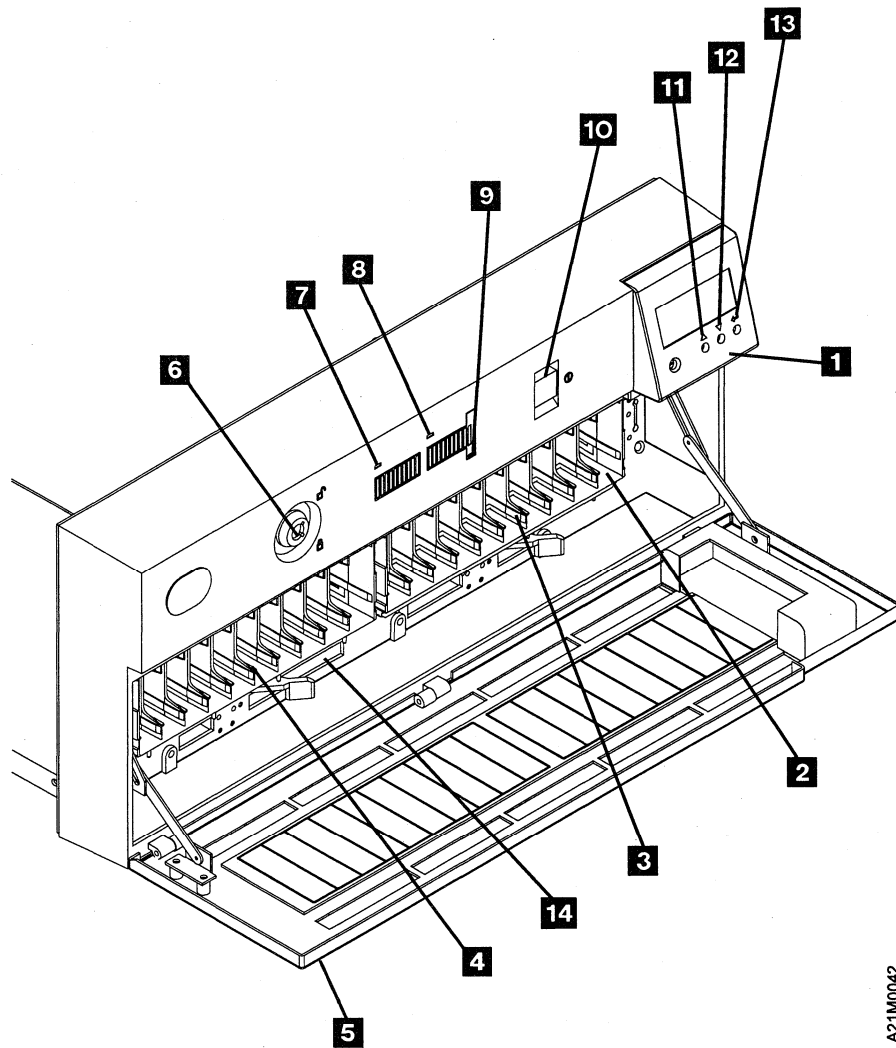

Figure 79. Front Assembly for Library Models

### **1** Operator Panel Display

See "Operator Panel Overview" on page 135 for a description of the operator panel.

### **2** Priority Cell

The library models have a priority cell that can be used to load or unload cartridges from the subsystem without removing the cartridge magazine. Because cartridges can be inserted without opening the door, the integrity of the tape inventory is not violated. To use this feature, magazine 1 must be present and the rightmost cartridge cell must be unused.

Its functions are as follows:

- When in automatic or manual mode, requests to mount an external cartridge can be satisfied by placing the specified cartridge into the priority cell in the import position and pressing START. The cartridge in the priority cell will be the next one loaded into the drive. When the drive has unloaded the cartridge, it will be returned to the priority cell in the export position.
- When in random mode, the priority cell acts as an import/export station for the automated library. Because cartridges can be inserted into the priority cell without opening the door, additions or removals can be made to the cartridge inventory under control of the host (initiator) without opening the door and violating the integrity of the inventory.

**Note:** When using the priority cell, the cartridge must be placed in the import position.

### **3 Magazine 1 Location**

### **4 Magazine 2 Location**

### **5 Door**

The door protects the integrity of the inventory in the library units. As long as the door remains closed, the host knows that the magazine inventory remains unchanged. If the door is opened, the host (initiator) is alerted that the inventory may have changed. The door also acts as a safety interlock. When the door is opened, the transport mechanism will complete any movement in progress and stop. The transport mechanism will not move until the door is closed. The library will restart when the door is closed without any further intervention by the operator.

**Note:** Be careful, when opening the library door, to **not** move cartridges from the export position back to the import position.

### **6 Security Key Lock**

The security key lock locks the door closed. The Security Key lock on the library helps maintain security for cartridges in the library unit. It is a physical lock only, and is not sensed or controlled by the initiator or device. When locked, the only way to add or remove cartridges to or from the library units is through the priority cell.

### **7 Magazine 2 In Use Indicator**

The yellow LED indicates the status of Magazine 2. When it is on, the operator should not add or remove cartridges to or from that magazine and should not remove that magazine from the library unit. The Magazine In Use LED is on when a cartridge from the magazine has been transported to the drive for processing, or when the library unit is in random mode and the initiator has issued the Prevent/Allow Medium Removal command with the prevent bit set.

The LED also turns on solid momentarily during power-on reset as a lamp test, and it flashes during bring-up diagnostics.

### **8 Magazine 1 In Use Indicator**

This yellow LED indicates the status of Magazine 1 and operates the same as indicator **7**.

### **9 Priority Cell In Use Indicator**

This yellow LED indicates the status of the priority cell. When the LED is on, a cartridge is in the priority cell or the priority cell is reserved for the cartridge currently being processed in the drive. When the LED is on, the operator should not place a cartridge in the priority cell or remove a cartridge from the priority cell. When the LED is not on, the operator can place a cartridge in the priority cell for processing or can remove a cartridge from the priority cell. The indicator is visible with the door open or closed.

This LED turns on solid momentarily during the power-on reset as a lamp test, and flashes during the power-on diagnostics. After completion of the power-on sequence, this LED is turned off until it is turned on by activity that involves the priority cell.

#### **10 Power On/Off Switch**

This switch is connected to the dc power supply by a cable. The switch removes dc power from the output of the power supply. There is no LED to indicate a power-on condition of the library units. The power is on when the operator panel is active.



**Note:** With the switch in the Off position, ac voltage is still available inside the subsystem power supply.

#### **11 Scroll Up Button**

#### **12 Scroll Down Button**

#### **13 Enter Button**

#### **14 Serial Number Label**

Located above the magazine locking lever, the serial number is required when requesting service.

---

## Power On/Off

The Power On/Off switch for the library models, (see **10** in Figure 79 on page 121), is a push button located above the door between display panel and Magazine In Use indicator.

At system power on, the operator will see the following conditions:

1. During the power-on self-test (POST) diagnostics, the priority cell indicator and both the Magazine In Use indicators will blink. This should take less than six minutes.
2. After the LEDs stop blinking and go to their normal state (depending on magazine and cartridge status), the normal Status screen will appear (see "Status Screen" on page 137). The Status screen will remain on the display until the operator pushes the ENTER button, which will cause the Options screen to be displayed.

Remote power control is not provided by the Magstar MP unit.

## Cartridge Import and Export Positions

As shown in Figure 80, the magazine design **1** for the library unit provides for retention of cartridges in each storage cell in two possible positions: the import position **2** and the export position **3**. This differential positioning allows the operator to readily see which cartridges have been processed. In the import position, the cartridge is fully inserted and flush with the edge of the magazine. In this position, the transport mechanism has easy access to the cartridge. In the export position, the cartridge is partially exposed and protrudes beyond the edge of the magazine by at least 39 mm (1.5 in). This position is used to facilitate cartridge removal by the operator.

**Note:** In random mode, the transport mechanism returns the cartridge to the import position for future reuse. If the initiator has requested that the cartridge should be exported from the library, then the cartridge is placed in the export position in the priority cell.

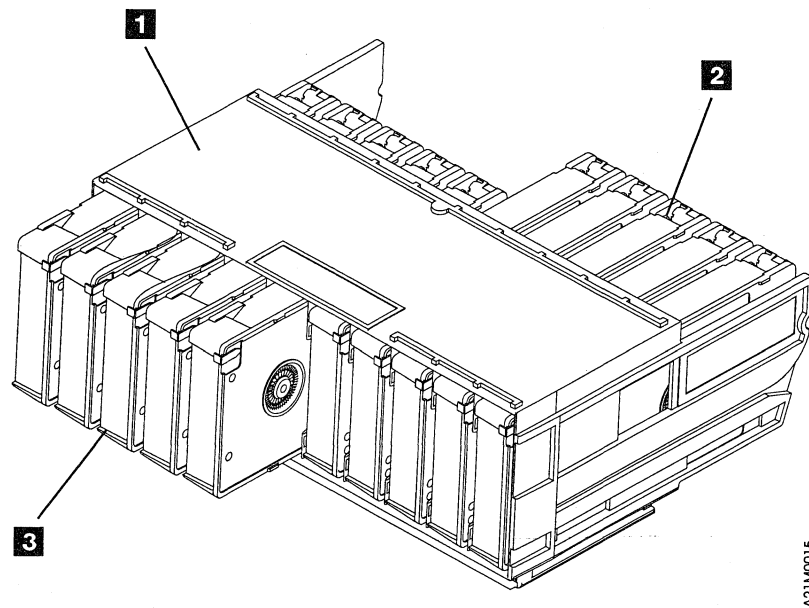

Figure 80. Magstar MP Cartridge Magazine (Viewed from the Operator Side)

## Loading Cartridges into a Magazine

Perform the following steps to load the magazine with cartridges when the magazine is not in the library (see Figure 81).

1. Set the empty magazine on a work surface with the release latch **1** facing you.
2. Hold the magazine and push the latch about 1/4 inch left to the release position.
3. Insert the cartridge in the orientation shown in Figure 81.

A cartridge lock is built into the magazine. The lock is automatically unlocked when the magazine is secured in the transport to make the cartridges easily accessible by both the operator and the transport. A simple thumb-operated slide mechanism allows the operator to temporarily unlock the magazine for cartridge removal and refilling. When the slide is released, the magazine automatically locks once again.

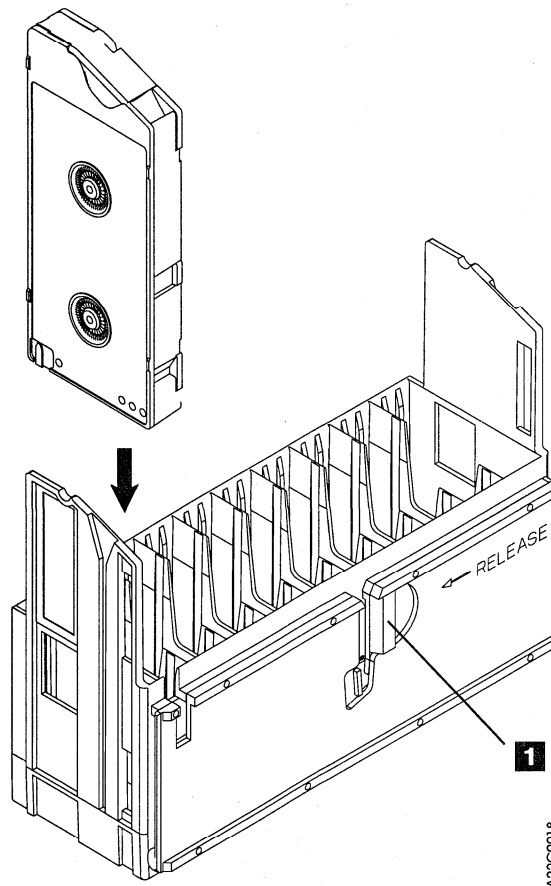

A22C0018

Figure 81. Loading a Cartridge in a Magazine (with the Operator Side Facing Down)

## Inserting or Removing a Magazine

There is a release lever under each magazine 1 and 2. Both levers look and operate alike. An example of how to insert the rightmost magazine (magazine 1) into the library unit follows. The procedure for the leftmost magazine (magazine 2) is identical.

To insert a magazine (see Figure 82):

1. Open the library door **1**.
2. Ensure that the magazine release lever **2** is in the open position (all the way to the right).
3. Slide the cartridge magazine into the magazine opening **3** until it seats fully. The magazine is oriented with its own release latch (see **1** in Figure 81 on page 125) on the bottom.

**Note:** If there are multiple cartridges in the magazine, they must all be evenly positioned in either the import or export position. If all of the cartridges in the magazine are not carefully and uniformly lined up in the import position, or all of them are not carefully and uniformly lined up in the export position, the magazine cannot be inserted.

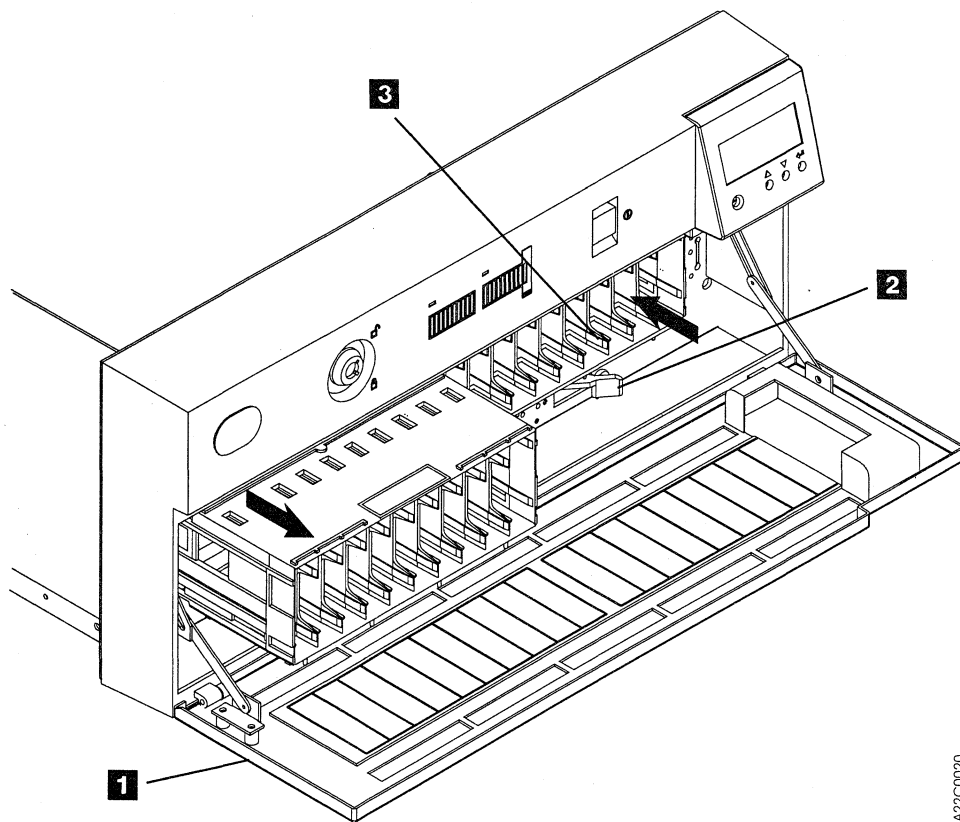

Figure 82. Loaded and Unloaded Magazine (with the Door in the Open Position)

4. Move the magazine release lever **2** all the way to the left to lock the magazine in place.
5. Close the library door **1**.

A22C0020

To remove a magazine (see Figure 82):

1. Open the library door **1**.
2. Move all exported cartridges back to the import position.  
**Note:** All the cartridges in a magazine must be evenly lined up in the import position or the magazine cannot be removed.
3. Move the library unit's magazine release lever **2** beneath the magazine to the open position (to the right).
4. Pull the magazine straight out as shown in Figure 82.
5. After removing the magazine from the Magstar MP library, close the door **1**.

## Unloading or Loading a Cartridge in a Library Magazine

Perform the following steps to load cartridges into a magazine when the magazine is in the library unit:

1. Unlock and open the library door **1**. Cartridge transport motion ceases while the door is open. If a cartridge is being processed in the drive, the processing will continue until the transport mechanism is requested to return the cartridge to its cell.
2. Ensure the magazine release lever **2** is in the open position (all the way to the right).
3. Remove the cartridges to be replaced from the magazine. Only the cartridges in the export position (partially ejected from the magazine) have been processed. Pull the cartridge straight out.
4. Insert new cartridges into the magazine in the orientation shown in Figure 83. Be sure to insert the cartridge to the full import position by pushing it gently into the magazine until it comes to a stop and even with the front of the magazine.
5. Close the door.

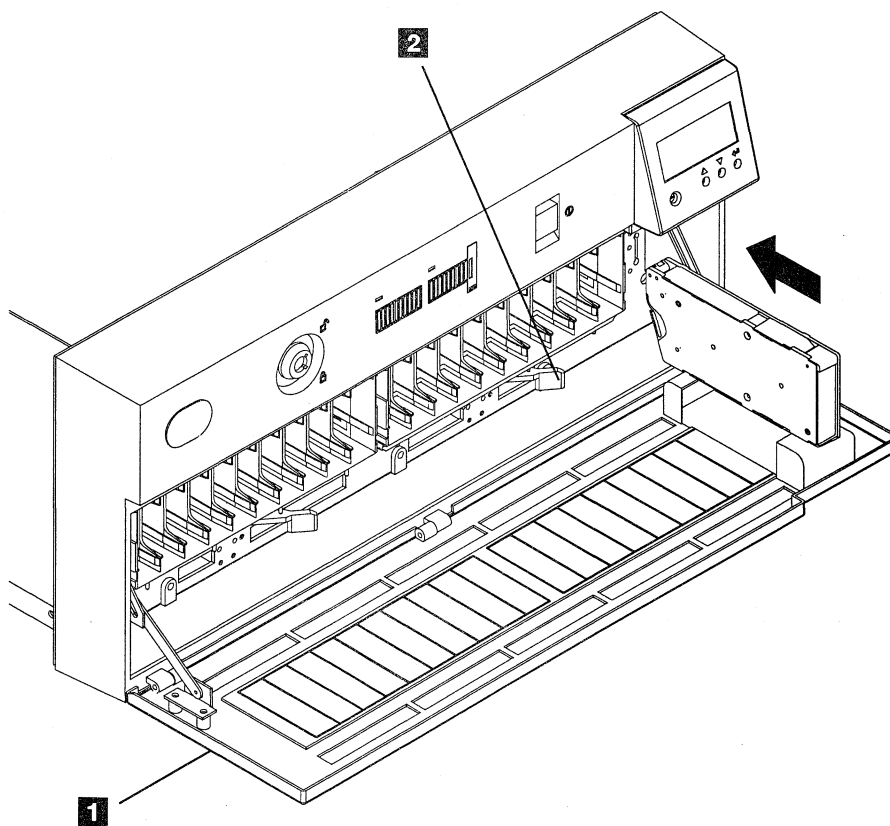

Figure 83. Loading a Cartridge in the Library

A22C0019



---

## Removing a Stuck Cartridge

If a cartridge does not unload when requested, turn the Power switch off and then on again. In most cases, this method will solve the problem and the cartridge will eject normally.

**Note:** You will lose any error message information indicated by the operator display when you power off. Before powering off the unit, write down the message information on the operator display so you can give this information to your service representative if a service call becomes necessary.

In those infrequent cases where turning the power off and then on again does not work, call for service.

---

## Inserting or Removing a Cleaning Cartridge

1. Change from the default Status screen to the Options Menu by pressing the Enter button.
2. Select CLEAN from the Options Menu and press Enter.
3. If inserting a cleaning cartridge in the library, go to step 5.
4. If removing a cleaning cartridge from the library, select REMOVE CLN TAPE and press Enter. The cleaning cartridge will be removed from its internal storage cell and placed in the priority cell. Remove the cleaning cartridge from the priority cell and continue with step 6.
5. Select INSERT CLN TAPE and press Enter. A message will appear prompting the operator to 'PUT CLEANING CARTRIDGE IN PRIORITY CELL PRESS ENTER'. Put the cleaning cartridge in the priority cell and press enter. The cleaning cartridge will be loaded in the library and stored in its internal storage cell.
6. Select CANCEL and press Enter to return to the Options Menu.

---

## Cleaning the Drive Unit Tape Path

**Note:** This procedure assumes a cleaning cartridge has been inserted into the library.

The tape path must be kept clean to prevent errors caused by contamination. A cleaning cartridge is shipped with each Magstar MP unit; it is intended for use only in a Magstar MP unit. A cleaning cartridge is identified by its gray file-protect selector and the label that reads IBM Magstar MP Cleaning Cartridge. The selector on an ordinary read/write cartridge is blue, and the label reads IBM Magstar MP Fast Access Linear Tape.

In normal operation, the drive determines the need for tape path cleaning and generates the CLEAN message by monitoring the number of processed megabytes and the number of nonpermanent errors for each drive. When either of these factors reaches a threshold, the device displays the CLEAN message. The CLEAN message is maintained across device power-on reset conditions.

When Automatic Cleaning is enabled (see “Setting Automatic Cleaning” on page 130), the library will automatically clean the tape drive without the need for operator intervention.

When the CLEAN operation is initiated by the operator (see “Manual Cleaning”), the cleaning cartridge is transported from its storage cell to the drive and performs the cleaning process. When cleaning is complete, the cleaning cartridge is returned automatically to its storage cell.

---

## Manual Cleaning

**Note:** This procedure assumes a cleaning cartridge has been inserted into the library.

The operator initiates cleaning by performing the following steps:

1. Change from the default Status screen to the Options Menu by pressing the Enter button.
2. If a cartridge is loaded in the drive, unload the drive. See Figure 90 on page 145.
3. Select the CLEAN DRIVE option from the Clean Menu. Press the Enter button. Select the drive number to be cleaned and press Enter. When the drive is available, the cleaning cartridge will be transported from its storage cell to the drive and perform the cleaning process. When cleaning is complete, the cleaning cartridge is returned automatically to its storage cell.
4. Select CANCEL and press Enter until the Options Menu appears.

---

## Setting Automatic Cleaning

1. Because the Magstar MP will be reset at the end of this procedure, you should make sure the drive(s) have been unloaded and are not being used by the host system.
2. Select EDIT CONFIG from the Options Menu and press ENTER.
3. Select AUTO CLEAN from the Edit Configuration Menu and press ENTER.
4. An asterisk (\*) in front of ENABLE or DISABLE indicates if automatic cleaning is enabled or disabled. If the display shows \*ENABLE, the library unit will automatically clean the tape drive(s) when they require cleaning. If the display shows \*DISABLE, the operator must take action to clean the tape drive(s) when cleaning is required. If the display shows both the ENABLE and the DISABLE menu options without asterisks in front, there is a mismatch in the settings for drive 1 and drive 2 (in dual-drive models). Select ENABLE or DISABLE, and press ENTER to correct the mismatch.

It is recommended to enable automatic cleaning. To keep the current configuration, select CANCEL and press ENTER. To change the configuration, move the arrow to select the desired configuration (ENABLE or DISABLE) and press ENTER. After making your choice, Select CANCEL and press ENTER to return to the Edit Configuration Menu.

5. Select CANCEL from the Edit Configuration Menu and press ENTER.

6. Select RESET DRIVE from the Unload and Reset Menu and press ENTER. Then select PROCEED and press ENTER. The Magstar MP will reset and the status screen will be displayed. Press ENTER to return to the Options Menu.

---

## Library Mode Selection

To change the operating mode of a library unit, perform the following steps in the order indicated:

1. At power on, the Status screen will be displayed. Press the Enter button to display the Options Menu.
2. Select SET LIBR MODE from the Options Menu and press the Enter button.
3. Select Drive 1 or Drive 2 and press Enter.
4. When the Set Library Mode Menu appears, use the Scroll Up and Scroll Down buttons to move the selection arrow (>) until it is pointing to the desired mode. Press the Enter button. The library unit will be set to the mode that you have selected. The Options Menu is displayed.
5. Select CANCEL and press Enter until the Options Menu is displayed.

For additional information, see "Library Modes of Operation" on page 115

---

## Pausing the Cartridge Sequence

In automatic mode, the library keeps the tape drive continually fed with cartridges. The next available cartridge is automatically loaded into the tape drive after the ejected cartridge is put back into the magazine.

The operator can pause the autoloading of cartridges into the drive by making the following selections on the Operator Panel:

1. If the STATUS SCREEN is displayed, press the ENTER button to display the Options Menu.
2. Select CART SEQUENCE from the Options Menu and press the ENTER button.
3. If the Magstar MP is a dual-drive library operating in Split Configuration, select the drive number to be paused.
4. Select PAUSE SEQUENCE from the Cartridge Sequence Menu.

When the tape in the drive has been unloaded, the library will not automatically load the next cartridge into the drive. In order to resume operation, the operator must select START on the Options Menu.

This operation is available only in Automatic Mode.

---

## Resetting the Cartridge Sequence

In automatic mode and manual mode, the library processes cartridges sequentially beginning at the rightmost cell position, proceeding from right to left as viewed from the front of the library.

The operator can reset the order that the cartridges are processed by making the following selections on the Operator Panel:

1. If the Status Screen is displayed, press the Enter button to display the Options Menu.
2. Select CART SEQUENCE from the Options Menu and press the ENTER button.
3. If the Magstar MP is a dual-drive library operating in Split Configuration, select the drive number to be reset.
4. Select RESET SEQUENCE from the Cartridge Sequence Menu.

When the tape in the drive has been unloaded, the library will not automatically load the next cartridge into the drive. The operator can then open the library door and insert or remove cartridges from the magazines.

In order to resume operation, the operator must select START on the Options Menu. Instead of resuming operation where it left off, the library loads the first cartridge it finds in the import position beginning at the rightmost cell position.

This operation is available only in Automatic Mode or Manual Mode.

---

## Library Configuration Selection

Library configuration is only available on Magstar MP Models C02 and CC12. To change the configuration of a library unit, perform the following steps in the order indicated:

1. At power on, the Status Screen will be displayed. Press the Enter button to display the Options Menu.
2. Select EDIT CONFIG from the Options Menu and press the Enter button.
3. Select SET LIBR CONFIG from the Edit Configuration Menu and press Enter.
4. An asterisk (\*) in front of BASE or SPLIT indicates the configuration that is currently selected. To keep the current configuration, select CANCEL and press Enter. To change the configuration, move the arrow to select the desired configuration (BASE or SPLIT) and press Enter. Select CANCEL from the Edit Configuration Menu and press Enter.
5. If a cartridge is loaded in drive 1 or drive 2, select UNLOAD DRIVE from the Unload and Reset Menu and press Enter; otherwise continue with step 8.
6. Select the drive number to be unloaded and press Enter. The cartridge will be unloaded from the drive and the status screen will be displayed. Press Enter to return to the Drive Selection Menu.
7. Repeat step 6 until there are no cartridges loaded in drive 1 or drive 2. Then select CANCEL to return to the Unload and Reset Menu.
8. Select RESET DRIVE and press Enter.

9. Select PROCEED and press Enter.
10. The Magstar MP will reset and the status screen will be displayed. The new library configuration will be displayed on line 3 of the operator panel display. (See **16** in Figure 86 on page 137).
11. If attached to an AS/400 system, re-IPL the AS/400 IOP card(s) to which the Magstar MP is attached.
12. If attached to a RISC System 6000, you must deconfigure the Magstar MP device at the host and then reconfigure it before using the new library configuration.

---

## Clearing Tape Drive Recover Status

When the tape drive does not know where to put a tape cartridge, it displays RECOVER status on the operator panel. For example, if the Magstar MP is powered off, then back on with a tape loaded in the drive, the Magstar MP does not know where to place the cartridge when it is unloaded from the drive. The tape drive goes into RECOVER status to allow the operator to choose where the cartridge should be moved. To clear the RECOVER status:

- \_\_\_ 1. Select START from the Options Menu.
- \_\_\_ 2. If asked, select the drive with the RECOVER status.
- \_\_\_ 3. On the Recovery Menu, select where the cartridge should be moved; the priority cell or one of the magazine cells (2 through 20).
- \_\_\_ 4. If the priority cell is selected, the cartridge will be moved to the export position in the priority cell.
- \_\_\_ 5. If one of the magazine cells is chosen, select the import or export positions. The tape will be moved to the selected magazine cell and placed in the desired position.

---

## Resolving Read/Write, Media, or FID FE Error

1. Check the integrity of the tape cartridge to ensure it is properly functioning and is not broken or otherwise obstructed by contaminants or improperly applied labels. Replace any broken or damaged cartridges.
2. If the cartridge is not damaged, and another Magstar MP tape drive is available, try the tape cartridge in the other tape drive. If the cartridge fails there also, replace the tape cartridge.
3. If read/write, media, or FID FE errors occur on the same Magstar MP tape drive with multiple different tape cartridges, call your service representative for repair.

---

## Resolving Bar Code Reader Problems

If there is a mismatch between the VOLSER and the bar code label, see "Resolving a Mismatch Between the Bar Code Label and VOLSER" on page 135.

If the host displays a message stating that either the VOLSER (Volume ID) does not match or a cartridge is not found, see "Resolving a Mismatch Between the Bar Code Label and VOLSER" on page 135.

If the bar code reader feature cannot read the bar code label on a tape, perform the following:

1. Check the cartridge labels for folds, missing pieces, tears, or any extraneous markings, such as smears or stains.
2. If the labels are dirty or marked, clean the labels. For cleaning information, see “Cartridge Label Cleaning” on page 162.
3. If a label needs to be replaced, a kit containing enough labels for 10 cartridges can be ordered. See “If You Need Additional Media” on page 17 and “Cartridge Label Replacement” on page 162 for additional information.
4. If the bar code reader still does not work, call your service representative.

---

## Setting the Volume ID

The cartridge label bar code on the Magstar MP cartridge is unique and is used to identify each cartridge. For Standard Label tape processing using the Bar Code Reader, the bar code labels and internally recorded VOLSER must match.

Most IBM tape management systems, such as ADSM and BRMS/400, use Standard Label tape processing. To maintain compatibility with Standard Label tape processing, it is required that the operator initialize tape cartridges using the VOLSER printed on the Bar Code Label. The internal VOLSER, on the tape, must be identical with the external VOLSER, which appears on the two matching Bar Code Labels of each cartridge. (See **1**, **2**, and **3**.)

**Attention:** Before using cartridges in a Magstar MP 3570 Tape Subsystem, with the Bar Code Reader feature installed, ensure the internal VOLSER matches the Bar Code Label.

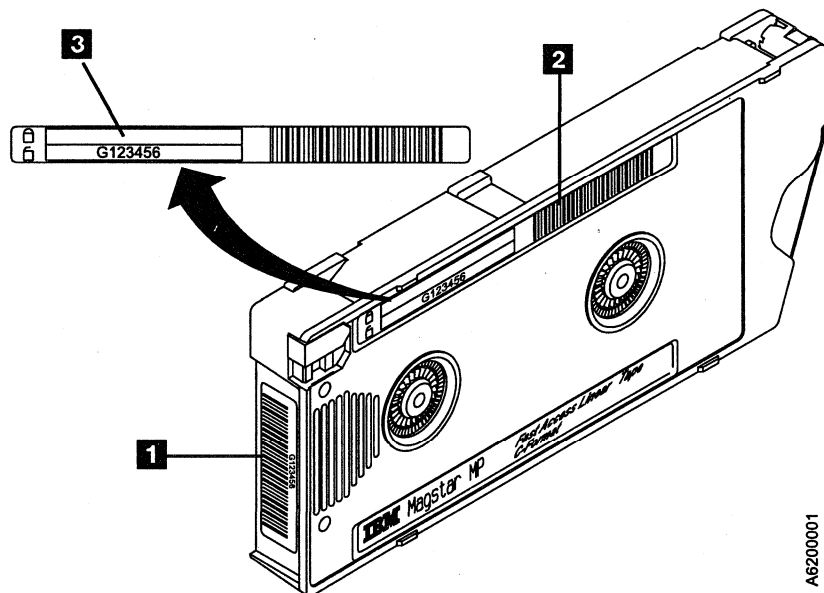

Figure 84. Magstar MP Cartridge Labels

---

## Resolving a Mismatch Between the Bar Code Label and VOLSER

If there is a mismatch between the Bar Code Label and the VOLSER, with which the tape was initialized, a set of cartridge labels can be ordered to match the Bar Code Label to the internal VOLSER. To receive the replacement labels, order PN 05H9643 for B-Format cartridges and PN 08L6192 for C-Format cartridges from IBM Supply Fulfillment Operations:

- 1-888-IBM-MEDIA in the United States, or
- +31 433 502 576 in Europe.

See “If You Need Additional Media” on page 17 for additional ordering information.

See “Cartridge Label Replacement” on page 162 for instructions explaining the procedures for removing the old labels and installing the new labels.

Instead of replacing the Bar Code Labels, the operator may choose to re-initialize the tape when the data contained on the tape has expired.

---

## Operator Panel Overview

Figure 85 shows the operator panel for the library models and illustrates the Liquid Crystal Display screen **1**:

Four types of screens are displayed on the operator panel:

- “Status Screen” on page 137
- “Intervention Screens” on page 141
- “Supplemental Message Screens” on page 143
- “Menu Screens” on page 143

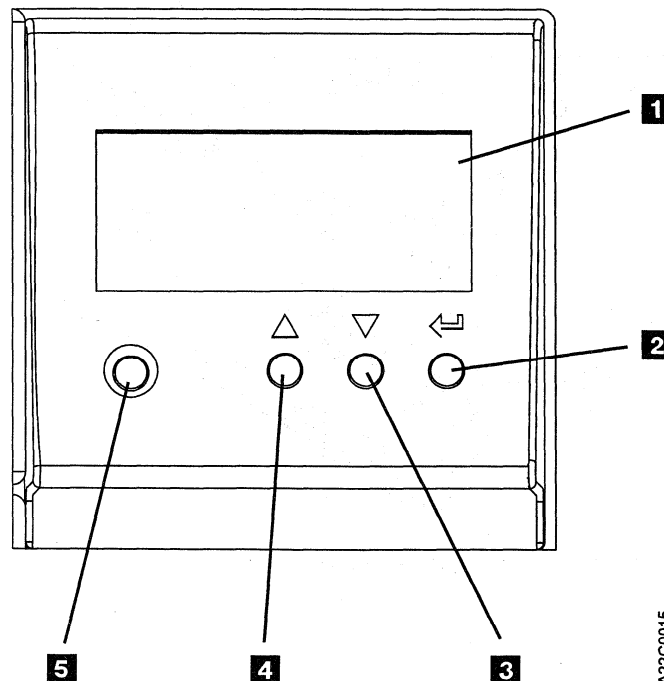

Figure 85. Operator Panel for Library Models

A22C0015

The operator panel has the following four control buttons:

**2 Enter button**

Pressing this button causes the device to select the option or perform the function indicated by the selection arrow (>).

**3 Scroll Down button**

Pressing the Scroll Down button moves the selection arrow (>) down to the next option, if any, on the menu. If none, the button action is ignored. The plus (+) symbol in the lower right corner of the display indicates that the list of additional menu items continues below the last item visible on the display. To view these selections, press the Scroll Down button.

**4 Scroll Up button**

Pressing the Scroll Up button moves the selection arrow (>) up to the next option, if any, on the menu. If none, the button action is ignored. The plus (+) symbol in the upper right corner of the display indicates that the list of additional menu items continues above the first item visible on the display. To view these selections, press the Scroll Up button.

**5 Menu Mode button**

The Menu Mode button allows selection of operator or service mode at any time.

At power on, the device will be in Operator mode.

The Menu Mode button is recessed slightly in the panel to prevent inadvertent mode changes by the operator and should not be used during normal operations. If you press the Menu Mode button and receive the message "Warning - Service Personnel Only," press the Enter button and then select CANCEL to return to normal operating mode. During the time the library unit is in service mode, the subsystem is offline to the host and unavailable for read and write operations.



## Status Screen

The explanation of the status and intervention screens that follows, describes the messages displayed on the operator panel by the library. It is possible for system application software to display other information or messages on the operator panel. Refer to the system application software documentation for explanations of any messages not described below.

The status screen (Figure 86 ) provides a view of the current operational status of the library and drive. This screen is the normal default screen. If some other screen is the current display and you want to check status, select SHOW STATUS from the Options Menu.

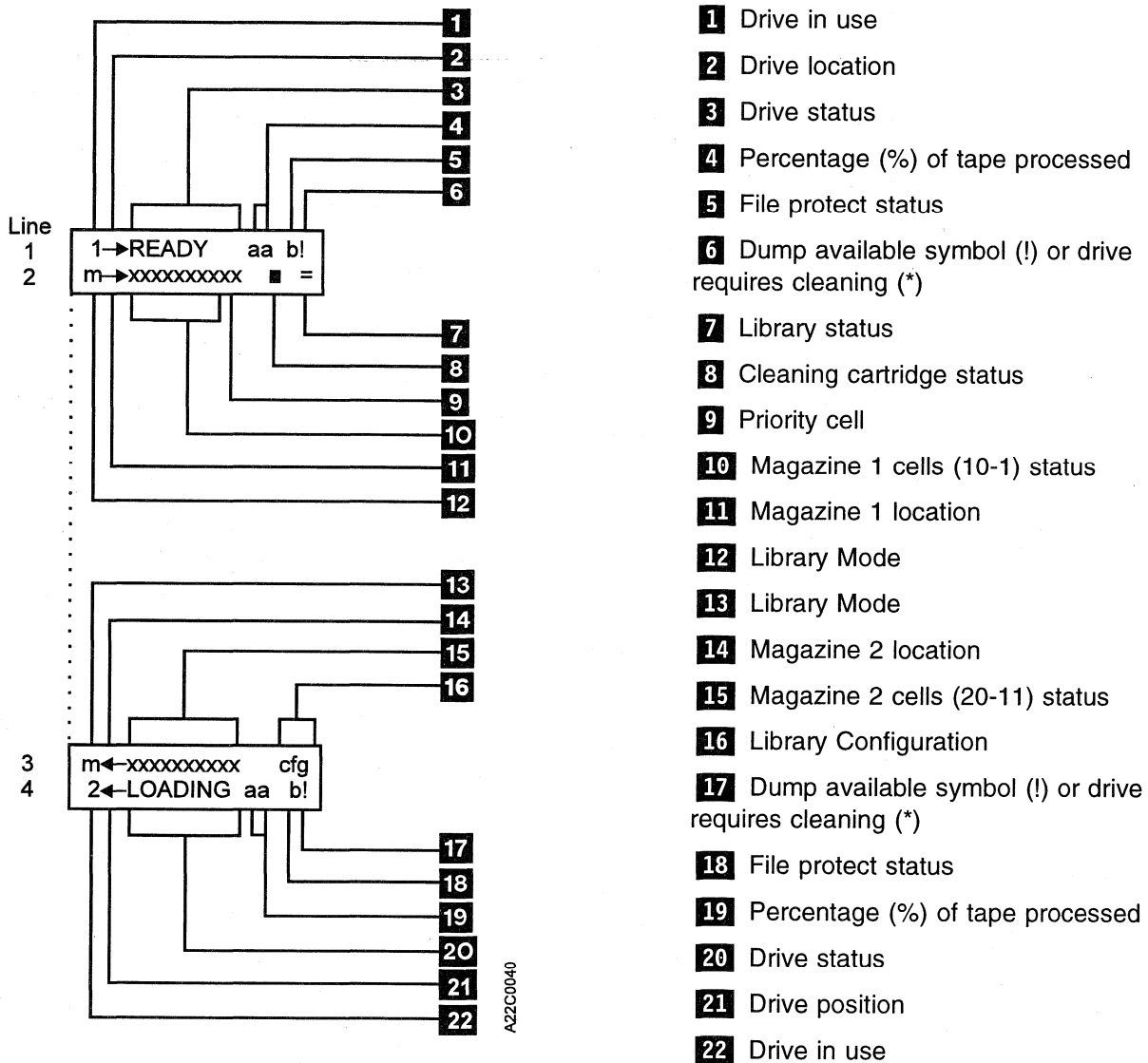

Figure 86. Status Screen

## Line 1:

Line 1 displays the status of drive 1.

**1** the numeral “1” indicates that the remainder of this line of text refers to drive 1.

**2** indicates the physical location of drive 1.

→ indicates drive 1 is located on the right.

**3** a word such as READY is displayed to indicate a brief status of drive 1. The following is a list of the words that are displayed in this field:

**[blank field]** The library is inactive and the drive is not loaded.

**ACCESSNG** The picker is moving to get a cartridge.

**CLEANING** A head cleaning operation is in process.

**CODE LVL** A code level mismatch exists between drives.

**DIAG RUN** The diagnostic tests are running.

**ERASING** The device is erasing data from the media.

**INIT** Drive is in process of resetting.

**LOAD PT** The volume in the device is positioned at load point.

**LOADING** The cartridge is being loaded into the drive.

**LOCATING** The device is moving the media to a specific location.

**READING** The device is reading data from the media to the device buffer.

**READY** The device is loaded, not moving media, and not performing a rewind-unload operation.

**RECOVER** Drive requires recovery; select START from Options Menu.

**REPLACE CLN CART** The cleaning cartridge has been used up and needs to be replaced.

**REWINDNG** The device is rewinding the media to the beginning of the logical volume.

**UCODE LD** Microcode is loading.

**UNLOADNG** The cartridge is being removed from the drive.

**WRITING** The device is writing data from the device buffer to the media.

**XFERRING** The picker is moving a cartridge to another slot or to the drive.

**4** indicates the percentage of media that has been *used* (processed) by drive 1.

**5** is a lock symbol that indicates the status of the file-protect switch on the cartridge currently loaded in drive 1.

The file-protected icon  is a *read only* symbol that indicates that the file-protect switch is in the write-prevent position.

The file-unprotected icon  is a *read/write* symbol that indicates that the file protect switch is in the allow-write position.

**6** when the exclamation point (!) is displayed, a dump is available for drive 1. A dump contains detailed information that pertains to the device operation at the time of a failure (this dump is available for the use of a service representative only). When the asterisk (\*) is displayed, drive 1 needs to be cleaned.



## Line 2:

Line 2 displays the status of magazine 1, the cleaning cartridge cell, and the library.

**7** indicates the library status; that is, if the library is moving, = is shown, if a cartridge is being moved, + is shown.

**8** indicates the status of the cleaning cartridge storage slot located inside the Magstar MP subsystem. A solid pattern  indicates that the cleaning cartridge is in the storage slot. A dash (-) indicates that no cleaning cartridge is present in the storage slot.

**9** indicates the state of the priority cell where the operator can load a cartridge.

- A solid pattern  indicates that a cartridge is present and that it is in the *import* position; that is, accessible to the library.
- An open pattern  indicates that a cartridge is present and that it is in the *export* position; that is, not accessible to the library.
- A one (1) indicates the cell is in use by drive 1.
- A two (2) indicates the cell is in use by drive 2.
- A dash (-) indicates that no cartridge is present in that position of the magazine.
- An hour-glass shape (an X filled in at the top and bottom) indicates the Magstar MP has not determined the status of a magazine cell.

**10** indicates the state of the ten storage elements associated with magazine 1 (including the priority cell). The cells are numbered from 10 to 1, left to right. See item **9** above for a list of symbols that can appear in this field.

**11** indicates the physical location of magazine 1

→ indicates magazine 1 is located on the right

**12** displays the library mode (A=AUTO, R=RANDOM, M=MANUAL) for all drives in a Base Configuration or associated with drive 1 in a Split Configuration. During a power-on reset before the microcode can determine the mode set in nonvolatile storage, N is displayed.

## Line 3:

Line 3 displays the status of magazine 2 and the library configuration.

**13** displays the library mode (A=AUTO, R=RANDOM, M=MANUAL) associated with drive 2 in a Split Configuration. During a power-on reset before the microcode can determine the mode set in nonvolatile storage, N is displayed.

**14** indicates the physical location of magazine 2.

← indicates magazine 2 is located on the left.

**15** indicates the state of the ten storage elements associated with magazine 2. The cells are numbered from 20 to 11, left to right. See **9** in the Line 2 description for a list of the symbols that are displayed in this field.

**16** indicates the library configuration.

BAS indicates the base library configuration.

SPL indicates the split library configuration.

## Line 4:

Line 4 displays the status of drive 2.

**17** when the exclamation point (!) is displayed, a dump is available for drive 2. A dump contains detailed information that pertains to the device operation at the time of a failure. When the asterisk (\*) is displayed, drive 2 needs to be cleaned.

**18** is a lock symbol that indicates the status of the file-protect switch on the cartridge currently loaded in drive 2. See **5** in the Line 1 description for a list of the symbols that are displayed in this field.

**19** indicates the percentage of media that has been *used* (processed) by drive 2.

**20** indicates the status of drive 2. See **3** in the Line 1 description for a list of the words that are displayed in this field.

**21** indicates the physical location of drive 2.

← indicates drive 2 is located on the left.

**22** the numeral "2" indicates that the remainder of this line of text refers to drive 2.

---

## Intervention Screens

Intervention messages are presented on the operator panel in the intervention screen. The intervention screen consists of a message displayed in a screen with a black border. The drive number which generated the message is listed on the top line.

Device activity or status messages are informational, not intervention notices. These messages are displayed on the Status screen. These messages include *reading*, *writing*, and *locating*.

The intervention message types are FID1 messages, FID2 messages, FID3 messages, FID4 messages, attention messages, and routine messages.

**Note:** When the FID message appears, write down the FID number and the drive number should they be needed by the service representative to describe the error condition. As you try to fix the error condition, the FID message that originally appeared will be replaced on the display screen with supplemental messages. You will not be able to restore this FID message to the screen unless you recreate the error condition.

- **FID1 Messages**

The FID1 message is displayed when a hardware failure occurs within the device. Call for service.

Figure 87 shows an example of the FID1 92 message posted by drive 2.



Figure 87. Error Message Example

- **FID2, FID3, and FID4 Messages**

The FID2, FID3, and FID4 messages indicate that the library requires service but can still be used. Schedule a service call.

- **ATTENTION Messages**

The ATTENTION messages indicate error conditions that you may be able to resolve.

After an Attention message is received, note the drive number and press the Enter key to observe any supplemental messages with additional information.

The ATTENTION messages can be either ATTENTION DRIVE or ATTENTION LIBRARY messages (see Figure 88).



Figure 88. Attention Message Example

- **Routine Messages**

Routine Messages consist of messages received from the host through the SCSI Display Message command. These messages include **MOUNT** (Mvolser prompts the operator to mount volser in the priority cell), **DEMOUNT** (Dvolser prompts the operator to remove volser from the priority cell), and messages from the device (for example, **\*CLEAN**, which prompts the operator to clean the tape drive when automatic cleaning is turned off). Another example of a routine message is **NO CARTRIDGE**. This message is displayed when the library is set to Automatic Mode and there are no cartridges remaining in the magazine(s) to be loaded in the drive.

The routine messages received through the Display Message command consist of mount messages, demount messages, and general (custom) messages.

## Resolving ATTENTION Messages

Many ATTENTION messages are caused by conditions that the operator should be able to resolve without the necessity of a service call. In these cases, pressing the Enter button will cause a supplemental message to appear that will further clarify the nature of the problem. Depending upon the supplemental message, the operator should take recommended actions to fix the problem on the spot.

If the supplemental message indicates DRIVE DISABLED UNTIL CLEANED, the tape drive must be cleaned before further use of the drive is allowed. This supplemental message is only displayed if the CLEAN message is repeatedly ignored. For instructions on cleaning the tape drive, see "Manual Cleaning" on page 130 and "Cleaning the Drive Unit Tape Path" on page 129. The Magstar MP can be configured for automatic cleaning. Refer to "Inserting or Removing a Cleaning Cartridge" on page 129 and "Setting Automatic Cleaning" on page 130.

If the supplemental message indicates REPLACE CLN CART, the cleaning cartridge has been used up and needs to be replaced. See "If You Need Additional Media" on page 47 for cleaning cartridge ordering information and "Inserting or Removing a Cleaning Cartridge" on page 129 for the replacement procedure. Continue to use the old cleaning cartridge until you receive the new one.

In the event that no effective operator resolution of an ATTENTION message is possible, call for service.

Do the following simple steps first whenever normal operation is disrupted:

- Ensure that all cartridges are properly positioned in magazine cells or the drive.
- Try to unload the cartridge. If a cartridge is stuck in the drive, see "Removing a Stuck Cartridge" on page 129.

- Check the integrity of the cartridge to see that it is properly functioning and is not broken or otherwise obstructed by contaminants or improperly applied user labels.
- Check the display panel to see if a closed lock symbol is present. If it is, the cartridge is write protected and will not allow a write operation to take place.
- Check to see if the write-protect tab is set in the upward position to protect the tape from being written on. If you are attempting to write on the tape with the write-protect tab upward, you will experience an error condition.
- Check to ensure that the cartridge is the proper type (Magstar MP Fast Access Linear Tape).
- Ensure that a cleaner cartridge has been inserted if one has been requested and, conversely, that no cleaner cartridge has been inserted if a data cartridge is required.
- Check to see if the display indicates FID1 95. If it does, you may have forgotten to remove the shipping bracket. Remove the bracket and continue the procedure. See step 5 on page 50 under “Verifying Operability of the Library Unit” on page 49.
- Ensure that the library is in operator mode (see **5** in Figure 85 on page 135).
- Turn the power off and then on again.

If the above steps do not resolve the problem, and the problem is due to a stuck cartridge, see “Removing a Stuck Cartridge” on page 129 and follow the procedure indicated. If this does not work, call for service.

---

## Supplemental Message Screens

Supplemental screens provide additional information to the operator to clarify an error condition or to advise the operator to follow a particular course of action to resolve specific error conditions.

Generally, it is necessary to press the Enter button after an error message appears to see the accompanying supplemental screen.

---

## Menu Screens

When a menu screen is present, use the Scroll Down button (see **3** in Figure 85 on page 135) or the Scroll Up button (see **4** in Figure 85 on page 135) to move the arrow (>) to the desired selection, and then press the Enter button (see **2** in Figure 85 on page 135). This operation will select the desired option from the menu.

**Note:** An option marked with an **asterisk** indicates the option is not available for selection or the option is the selection currently in use by the library. For example: if the drive is not loaded with a tape cartridge, the UNLOAD DRIVE option will be marked with an **asterisk** indicating it is not available for selection.

## Operator Menus

Figure 89 on page 144 shows the operator menu functions. (The bold text in the figure shows the names of the menus.)

These menus are available after the successful completion of the power-on self-test.

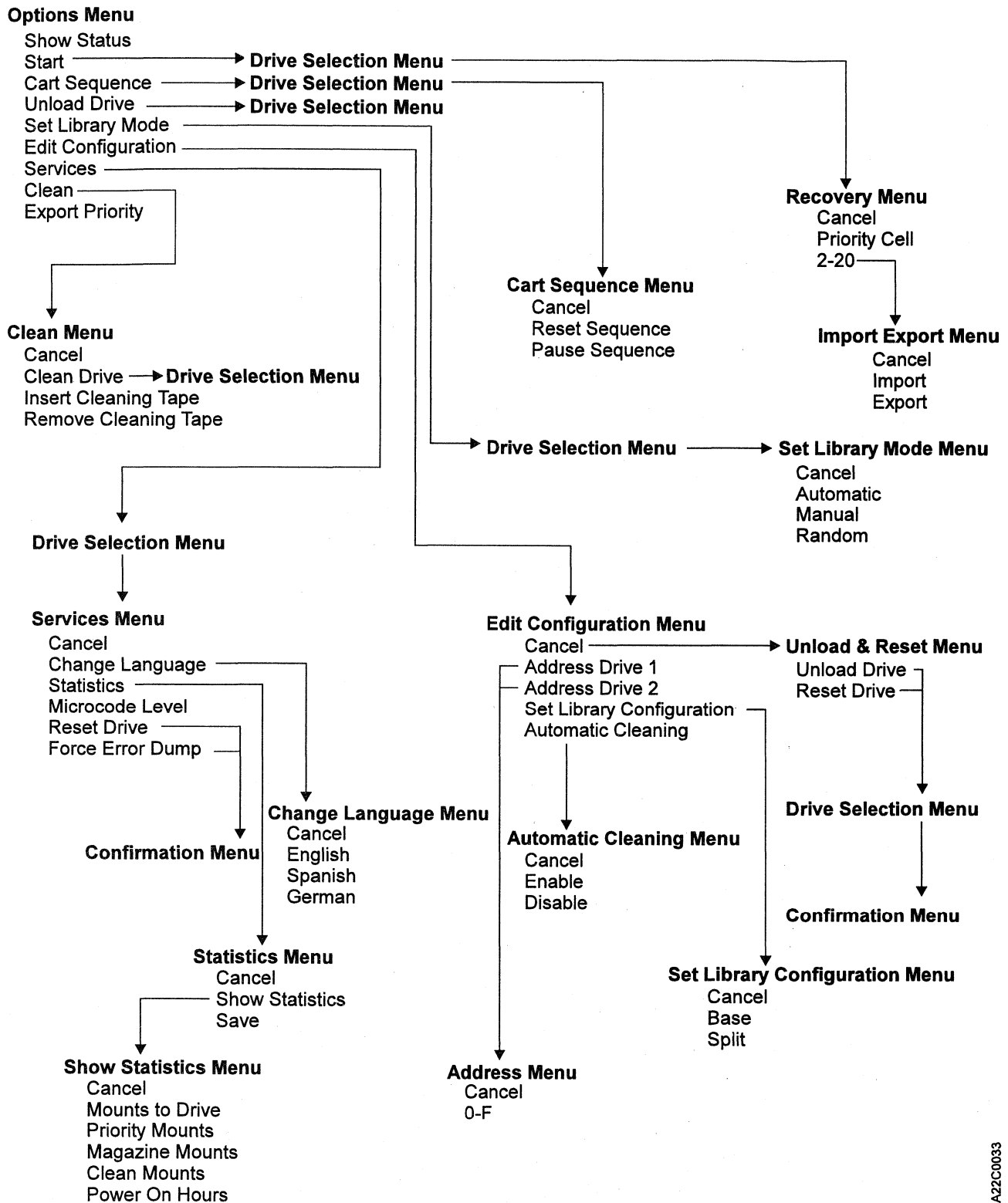

A22C0033

Figure 89. Operator Menus



# Options Menu

*Figure 90. Options Menu*

Function	Next Menu
Show Status	"Status Screen" on page 137
Start	"Drive Selection Menu" on page 146
Cart Sequence	After "Drive Selection Menu" on page 146 to "Cartridge Sequence Menu" on page 146
Unload Drive	"Drive Selection Menu" on page 146
Set Library Mode...	After "Drive Selection Menu" on page 146 to "Set Library Mode Menu" on page 147
Edit Configuration...	"Edit Configuration Menu" on page 147
Services...	After "Drive Selection Menu" on page 146 to "Services Menu" on page 150
Clean...	"Clean Menu" on page 152
Export Priority	—

### Show Status

Displays the Status screen (see "Status Screen" on page 137).

### Start

Loads cartridge into the drive in automatic or manual mode, or starts the library error recovery. (See "Clearing Tape Drive Recover Status" on page 133.)

### Cart Sequence

Allows the operator to pause or to reset the sequence of cartridges processed by the drive.

### Unload Drive

After selecting the drive to be unloaded, it causes the drive to rewind and unload the cartridge in the drive. If the library is in Random mode, the cartridge destination is selectable by the operator. (See "Clearing Tape Drive Recover Status" on page 133.)

### Set Library Mode

Sets the library mode to automatic, manual, or random.

### Edit Configuration

Allows the operator to perform configuration tasks.

### Services

Allows the operator to perform miscellaneous tasks, such as setting the language used on the panel.

### Clean

Allows cleaning of the drive tape path and cleaner cartridge handling.

### Export Priority

Moves a cartridge in the priority slot into the export position.

## Drive Selection Menu

This menu is not applicable to single-drive libraries.

<i>Figure 91. Drive Selection Menu</i>	
Function	Next Menu
Cancel	Previous menu
Drive 1	–
Drive 2	–

### Cancel

Displays the previous menu that was active.

### Drive 1

Selects Drive 1 as the drive to be used when displaying the next menu, or when performing the selected option.

### Drive 2

Selects Drive 2 as the drive to be used when displaying the next menu, or when performing the selected option.

## Cartridge Sequence Menu

<i>Figure 92. Cartridge Sequence Menu</i>	
Function	Next Menu
Cancel	After "Cartridge Sequence Menu" to "Options Menu" on page 145
Pause Sequence	"Options Menu" on page 145
Reset Sequence	"Options Menu" on page 145

### Cancel

Causes the "Drive Selection Menu" to appear.

### Pause Sequence

This option causes the drive to stop loading cartridges.

- If the drive is set to Automatic Mode and the Pause Sequence option is selected, the drive will stop processing cartridges when the tape currently loaded in the drive has been unloaded. In order to resume operation, the operator must select START on the Options Menu. The drive will then load the next available cartridge.
- The Pause Sequence option is not available if the drive is set to Manual or Random Mode of Operation.

### Reset Sequence

This option resets the order in which cartridges are processed by the drive.

- If the drive is set to Automatic Mode or Manual Mode, and the Reset Sequence option is selected, the drive will stop processing cartridges when the tape currently loaded in the drive has been unloaded. In order to resume operation, the operator must select START on the Options Menu. Instead of resuming operation where it left off, the library loads the first cartridge it finds in the import position beginning at the rightmost cell position.

- The Reset Sequence option is not available if the drive is set to Random Mode of Operation.

## Set Library Mode Menu

<i>Figure 93. Set Library Mode Menu</i>	
Function	Next Menu
Cancel	After "Drive Selection Menu" on page 146 to "Options Menu" on page 145
Automatic	After "Drive Selection Menu" on page 146 to "Options Menu" on page 145
Manual	After "Drive Selection Menu" on page 146 to "Options Menu" on page 145
Random	After "Drive Selection Menu" on page 146 to "Options Menu" on page 145

### Cancel

Causes the "Drive Selection Menu" on page 146 to appear.

### Automatic, Manual, or Random

See "Library Modes of Operation" on page 115.

## Edit Configuration Menu

<i>Figure 94. Edit Configuration Menu</i>	
Function	Next Menu
Cancel	"Unload & Reset Menu" on page 149 or "Options Menu" on page 145
Address Drive 1	"Address (SCSI ID) Drive 1 or Drive 2 Menu" on page 148
Address Drive 2	"Address (SCSI ID) Drive 1 or Drive 2 Menu" on page 148
Set Library Configuration	"Set Library Configuration Menu" on page 148
Automatic Cleaning	"Automatic Cleaning Menu" on page 149

### Cancel

Causes the "Unload & Reset Menu" on page 149 to appear if any changes were made to the configuration; otherwise the "Options Menu" on page 145 will appear.

### Address Drive 1

Allows the operator to select the SCSI address to be used for the device-to-host interface for tape drive 1. The address consists of one hexadecimal digit that specifies the SCSI ID for that interface.

### Address Drive 2

Allows the operator to select the SCSI address to be used for the device-to-host interface for tape drive 2. The address consists of one hexadecimal digit that specifies the SCSI ID for that interface. (This menu item is not applicable to single-drive libraries.)

### Set Library Configuration

Allows the operator to configure the library to operate in base or split configuration.

### Automatic Cleaning

Allows the operator to choose whether or not the library unit will automatically clean the tape drive(s) when they require cleaning.

## Address (SCSI ID) Drive 1 or Drive 2 Menu

<i>Figure 95. Set Address (SCSI ID) Menu</i>	
Function	Next Menu
Cancel	"Edit Configuration Menu" on page 147
0–F (hexadecimal)	"Edit Configuration Menu" on page 147

**Note:** The address must be defined also at the host.

### Cancel

Causes the "Edit Configuration Menu" on page 147 to appear.

### <value>

Allows the operator to set the SCSI ID of the library. The value can be from 0–F (16 addresses in hexadecimal).

### Notes:

1. You must select Reset Drive from the **Unload and Reset Menu** or switch off power to the device and then switch on power to activate the new address.
2. The physical drive address switch is ignored for library models. The address is only selected at the operator panel and retained in nonvolatile memory.

## Set Library Configuration Menu

<i>Figure 96. Set Configuration Menu</i>	
Function	Next Menu
Cancel	"Edit Configuration Menu" on page 147
Base	"Edit Configuration Menu" on page 147
Split	"Edit Configuration Menu" on page 147

### Cancel

Causes the "Edit Configuration Menu" on page 147 to appear.

### Base

Allows the Magstar MP to be configured to operate in base mode.

### Split

Allows the Magstar MP to be configured to operate in split mode.

See "Library Configurations" on page 117

## Automatic Cleaning Menu

<i>Figure 97. Automatic Cleaning Menu</i>	
Cancel	"Edit Configuration Menu" on page 147
Enable	"Edit Configuration Menu" on page 147
Disable	"Edit Configuration Menu" on page 147

### **Cancel**

Causes the "Edit Configuration Menu" on page 147 to appear.

### **Enable**

Allows the Magstar MP to automatically clean the tape drives when cleaning is required.

### **Disable**

The Magstar MP will not automatically clean the tape drives when cleaning is required.

If the display shows \*ENABLE, the tape drives will be cleaned automatically. If the display shows \*DISABLE, the operator must take action to clean the tape drive(s) when cleaning is required. If the display shows both the ENABLE and the DISABLE menu options without asterisks in front, there is a mismatch in the settings for drive 1 and drive 2 (in dual-drive models). Select ENABLE or DISABLE, and press ENTER to correct the mismatch.

**Note:** It is recommended that automatic cleaning be enabled.

## Unload & Reset Menu

<i>Figure 98. Unload &amp; Reset Menu</i>	
<b>Function</b>	<b>Next Menu</b>
Unload Drive	After "Status Screen" on page 137 to "Unload & Reset Menu"
Reset Drive	After confirmation, to "Status Screen" on page 137

### **Unload Drive**

Causes the device to rewind and unload the cartridge in the device. Press Enter to return to the Unload & Reset Menu.

### **Reset Drive**

Causes the tape drive to perform a power-on reset.

## Services Menu

<i>Figure 99. Services Menu</i>	
Function	Next Menu
Cancel	After "Drive Selection Menu" on page 146 to "Options Menu" on page 145
Change Language	"Change Language Menu"
Statistics...	"Statistics Menu" on page 151
Microcode Level	After microcode level display, to "Services Menu"
Reset Drive	After confirmation, to "Services Menu"
Force Error Dump	After confirmation, to "Services Menu"

### Cancel

Causes the "Drive Selection Menu" on page 146 to appear.

### Change Language

Allows the operator to select the operator panel language.

### Statistics

Displays the number of times certain events occurred.

### Microcode Level

Displays the microcode level.

### Reset Drive

Causes the library to perform a power-on reset.

### Force Error Dump

For service use only.

## Change Language Menu

<i>Figure 100. Change Language Menu</i>	
Function	Next Menu
Cancel	"Services Menu"
English	"Services Menu"
Spanish	"Services Menu"
German	"Services Menu"

### Cancel

Causes the "Services Menu" to appear.

### <language>

Allows the operator to select the operator panel language. The languages supported are English, Spanish, or German.

## Statistics Menu

<i>Figure 101. Statistics Menu</i>	
Function	Next Menu
Cancel	"Services Menu" on page 150
Show Statistics	"Show Statistics Menu"
Save	"Statistics Menu"

### **Cancel**

Causes the "Services Menu" on page 150 to appear.

### **Show Statistics**

Causes the "Show Statistics Menu" to appear.

### **Save**

Causes the statistics to be saved in nonvolatile storage.

## Show Statistics Menu

<i>Figure 102. Show Statistics Menu</i>	
Function	Next Menu
Cancel	"Statistics Menu"
Mounts to Drive	"Show Statistics Menu"
Priority Mounts	"Show Statistics Menu"
Magazine Mounts	"Show Statistics Menu"
Cleaning Mounts	"Show Statistics Menu"
Power-on Hours	"Show Statistics Menu"

### **Cancel**

Causes the "Statistics Menu" to appear.

### **Mounts to Drive**

Displays the total number of times a cartridge was mounted in the drive.

### **Priority Mounts**

Displays the total number of times a cartridge was loaded in the priority cell.

### **Magazine Mounts**

Displays the total number of times a cartridge was loaded in any of the cells of the magazine.

### **Cleaning Mounts**

Displays the total number of times a cartridge was moved from the cleaning cartridge slot to the tape drive.

### **Power-on Hours**

Displays the total number of hours the device was powered on.

## Clean Menu

<i>Figure 103. Clean Menu</i>	
Function	Next Menu
Cancel	"Options Menu" on page 145
Clean Drive	"Drive Selection Menu" on page 146
Insert Cleaning Tape	–
Remove Cleaning Tape	–

### **Cancel**

Causes the "Options Menu" on page 145 to appear.

### **Clean Drive**

After selecting the drive to be cleaned, it loads the cleaner cartridge from the internal cleaner slot into the drive. Once cleaned, the cartridge is returned to the internal cleaner slot. See "Manual Cleaning" on page 130.

### **Insert Cleaning Tape**

Moves the cleaning cartridge from the priority slot to the internal cleaner slot. If a cartridge is not present, a message will be displayed that prompts the operator to put the cleaning cartridge into the priority slot.

### **Remove Cleaning Tape**

Moves the cleaning cartridge from the internal cleaner slot to the priority slot.

## Confirm Mode Change Menu

<i>Figure 104. Confirm Mode Change Menu</i>	
Function	Next Menu
Cancel	Previous menu
Proceed	"Options Menu" on page 145

When the Menu Mode button is pressed, this menu is displayed when switching from operator to service mode or service to operator mode (dependent on job activity).

### **Cancel**

Displays the previous menu that was active before the Menu Mode button is pressed.

### **Proceed**

Forces the device offline if going to service mode.

If write activity exists, any write data in the device is lost. The Proceed option results in job termination.

**Attention:** The device should be quiesced by the host (that is, the device should be varied offline) before entering service mode. The online status of the device is restored when changing from service mode to operator mode.



## Recovery Menu

<i>Figure 105. Recovery Menu</i>	
Function	Next Menu
Cancel	After "Drive Selection Menu" on page 146 to "Options Menu" on page 145
Priority Cell	"Options Menu" on page 145
2 – 20	"Import Export Menu"

### **Cancel**

Causes the "Drive Selection Menu" on page 146 to appear.

### **Priority Cell**

Moves the cartridge to the export position in the priority cell.

### **<value>**

Allows the operator to select the magazine cell where the cartridge will be placed.

## Import Export Menu

<i>Figure 106. Import Export Menu</i>	
Function	Next Menu
Cancel	"Recovery Menu"
Import	"Options Menu" on page 145
Export	"Options Menu" on page 145

### **Cancel**

Causes the "Recovery Menu" to appear.

### **Import**

Causes the cartridge to be placed in the import position of the desired magazine cell.

### **Export**

Causes the cartridge to be placed in the export position of the desired magazine cell.

---

## Updating Microcode from an AS/400

Microcode for Magstar MP tape drives directly attached to an AS/400 system can be updated by the AS/400 using the PTF process.

### Notes:

1. The FC 2729 adapter shares a Combined Function IOP with the communications subsystems. Resetting the 2729 will disrupt the associated communications adapters.
2. If the Magstar MP dual-drive library is in Split Configuration, microcode update is not supported using the PTF process. The service representative must update the Magstar MP using an FMR tape according to the instructions in the maintenance information manual.
3. If both drives in a Magstar MP dual-drive library are attached to the same AS/400 system (Base Configuration), both drives will be updated with new microcode at the same time when the PTF is applied. **Both tape drives in the Magstar MP must be at the same microcode level for the library to operate correctly.**
1. Determine if any PTFs are required for attachment of the Magstar MP 3570 Tape Subsystem. PYFs for all supported AS/400 releases are listed in INFO APAR II10363. This information APAR contains the most current PTF information for all supported releases and important information concerning attachment of the Magstar MP 3570 Tape Subsystem to the AS/400.
2. Before applying the PTFs and IPLing the input/output processor (IOP), verify the drive(s) are unloaded and not being used by the AS/400 system.
3. The PTFs can now be applied and the IOP can be IPLed. The IPL causes the Magstar MP microcode load to proceed.
4. When the microcode load is complete, the drive performs a soft power-on reset (restarts the code).

Wait at least five (5) minutes after the IOP has finished with its IML before powering off or resetting the drive. If the drive is powered off or reset before the drive completes its power-on sequence, the drive logic card may be damaged.

**Note:** If an error occurs, a message will be displayed that an error occurred. Whether successful or not, the drive will be reset by the device microcode.

---

## Updating Microcode from RS/6000 by Using TAPEUTIL

**Note:** If updating microcode in a Magstar MP dual-drive library, update the microcode in drive 2 before drive 1. Then update the microcode in drive 1. Both tape drives in the Magstar MP must be at the same microcode level for the library to operate correctly.

This procedure downloads microcode to the tape drive from a file or diskette. This diskette must be in AIX/UNIX format. The Microcode Load utility is only supported on the IBM Magstar MP 3570 tape drives.

1. Verify the drive(s) are unloaded.
2. verify the drive(s) are not in use by another host.

3. Insert the diskette with the microcode load into the system diskette reader.
4. Start the tape utility program by typing **tapeutil** at the prompt.
5. Select Tape Drive Service Aids from the menu by selecting **Tape Drive Service Aids** option and pressing Enter.
6. Select Microcode load from the following panel, then press ENTER.

```

IBM Tape Device Service Aid Menu                                700000
Select One of the Service Aids to be performed

Force Microcode Dump
  Perform a microcode dump of the system. The dump is stored in
  the device.
  After the dump is performed it must be read using Read Dump.
Read Dump
  Transfer a dump from the tape device to a host file, diskette or
  a tape cartridge.
Microcode load
  Download microcode from host file or diskette to tape device via
  SCSI bus.
Error Log Analysis
  Analyze system error log for device.
F3=Cancel                                                    F10=Exit

```

7. Select a **Device** and press **F7=Commit** from the following pane. You must press **F7=Commit** after selecting the drive.

**Note:** If updating microcode in a Magstar MP dual-drive library, update the microcode in drive 2 **before** drive 1.

```

IBM Tape Device Selection Menu                                900000
Select One of the devices listed below

NAME          LOCATION      TYPE
rmt2          00-05-01-10  IBM 3570 Tape Drive and Medium Changer
rmt3          00-05-01030  IBM 3570 Tape Drive and Medium Changer

F3=Cancel                                           F10=Exit

```

8. If loading the microcode from the diskette reader, press **F7=Commit** from the following panel. Otherwise, enter the **path** and **filename** and press **F7=Commit**.

Enter the filename **/xxx.yyyy** in the source field where xxx.yyyy is the filename of the microcode file to be loaded. For example, type **/762.fmrz**.

You must press **F7=Commit** after entering the filename.

```
Prompting for Srce File for Operation on rmt3 located at 00-05-01-30
                                                    B00000

Please enter the following fields...

Enter Filename:                                     /dev/rfd0 +/-

F1=Help      F2=Refresh      F3=Cancel      F4=List
F5=Reset     F7=Commit       F10=Exit
```

9. While the Microcode load takes place, the display shows:

```
"Operation running, please stand by"
```

10. When the microcode load completes, the initiator display shows:

```
Operation completed successfully!
```

The drive performs a soft power-on reset (restart the code).

**Note:** If an error occurs, a message will be displayed that an error occurred. Whether successful or not, **the drive will be reset** by the device microcode.

11. Press **F10** to exit the microcode load.

12. Press **q** to quit tapeutil.

13. Remove the diskette from the diskette reader.

**Note:** You must have root authority to do the following step.

14. Update the VPD data in the host RS/6000 by unconfiguring the device.

**(Example: rmdev -l rmt3)** and reconfiguring the device **(Example: mkdev -l rmt3)**.

15. If updating microcode in a Magstar MP dual-drive library, repeat these steps to update the microcode in drive 1 after drive 2 has been updated.

---

## Updating Microcode from a Sun System

See “Updating Microcode from a Sun System” in the “Common Procedures” chapter of the *IBM Magstar MP 3570 Tape Subsystem Maintenance Information, C-Series Models*.

---

## Updating Microcode from an HP-UX System

See “Updating Microcode from an HP-UX System” in the “Common Procedures” chapter of the *IBM Magstar MP 3570 Tape Subsystem Maintenance Information, C-Series Models*.

---

## Updating Microcode from a Windows NT System

See “Updating Microcode from a Windows NT System” in the “Common Procedures” chapter of the *IBM Magstar MP 3570 Tape Subsystem Maintenance Information, C-Series Models*.



---

## Chapter 10. Handling the Tape Cartridge and Magazine

The Magstar MP Tape Subsystems are precision mechanical devices. To maintain their maximum reliability, the operator should take time to inspect and clean not only each cartridge used, but each library unit magazine as well.

---

### Unpacking the Cartridges

Before you use the cartridges, condition them to the normal operating environment for at least 24 hours. See "Operating Environment" on page 163.

---

### Handling the Cartridges

Incorrect handling or an incorrect environment can damage the magnetic tape or the cartridges. See "Damaged Cartridges" on page 161 for information about damaged cartridges. To avoid damage to your tape cartridges and to ensure continued high reliability on your subsystem, perform the following:

- **When you load a cartridge into the 3570 Tape Subsystem or you handle a cartridge, ensure that the cartridge case is clean.** Dirty tape cartridges can cause problems in loading or the loss of recorded data. If a cartridge case is dirty, follow the instructions in "Contaminants" on page 160.
- **Do not carry cartridges loosely in a box or basket.**
- **Do not load a damaged tape cartridge into a tape drive.** Damaged cartridges can interfere with the reliability of your subsystem. (For specific information about damaged cartridges, see "Damaged Cartridges" on page 161.) If a cartridge is dropped, inspect it for damage before you use it.
- **Never touch the tape.** Opening the cartridge door to expose the tape and then touching it will cause problems. Handling the tape can damage the tape surface or tape edges, which may interfere with read or write reliability.
- **Do not expose the tape cartridge to moisture or direct sunlight.**
- **Do not expose recorded or blank cartridges to stray magnetic fields greater than 100 oersteds (such as those existing near high-current cables or power supplies).** Such exposure can cause the loss of recorded data or make the blank cartridge unusable.
- **Do not attempt to degauss or ac bulk erase a tape cartridge.** Degaussing will make the tape cartridge unusable.
- **Maintain the conditions described in "Storage Environment" on page 163 for all cartridges stored outside your operating environment.**

---

### Stacking the Cartridges

Although cartridges are shipped and should be stored with the reel in the vertical position, you can lay the cartridges flat temporarily while moving them. The bottom of each cartridge has two raised areas that fit into indentations on the top of another cartridge. This construction helps prevent the cartridges from sliding off one another when you move a stack of them.

Do not stack more than six cartridges. See "Storage Environment" on page 163 for recommendations on the storage of cartridges.

---

## Contaminants

Monitor the conditions of all magazines and cartridges for contaminants. They should be inspected and cleaned of any contaminant before insertion into a tape subsystem.

- Before inserting a magazine into a library unit, inspect the magazine for contaminants. Wipe the exterior of the magazine with a lint-free cloth, lightly moistened with tape unit cleaner. The cleaner is available as IBM Tape Unit Cleaner, P/N 13F5647.
- Inspect all cartridges when either inserting or removing them from a Model C00 unit or from the library magazine. Damaged or dirty cartridges can reduce subsystem reliability and cause the loss of recorded data. If dirt or other contaminant appears on the cartridge, wipe the outside surfaces, especially the sides of the cartridge, with a lint-free cloth that is lightly moistened with cleaning fluid or its equivalent.

**Attention:** Do not allow any liquid (including tape unit cleaner) to contact the medium.

- Ensure that all cartridge surfaces are dry before loading a cartridge.

---

## Cartridge Degaussing and Disposal

Under the current rules of the Environmental Protection Agency (EPA), regulation 40CFR261, the Magstar MP Fast Access Linear Tape cartridge is classified as nonhazardous waste. As such, it may be disposed in the same fashion as normal office trash. These regulations are amended from time to time and should be reviewed at the time of disposal.

If local, state, or country (non-U.S.A.) regulations are more restrictive than EPA 40CFR261, they must be reviewed before the disposal of cartridges.

If the tape cartridge is to be disposed in a secure manner, the data on cartridges can be erased by using a high-energy <sup>1</sup> ac degausser. Degaussing makes the tape cartridge unusable.

If you burn the cartridges and the tape, you must ensure that the incineration complies with all applicable regulations.

---

<sup>1</sup> A minimum of 4000 Gauss



---

## Damaged Cartridges

Ensure continued use of your cartridges and subsystem as follows:

- **Do not attempt to open the cartridge case at any time.** The magnetic tape inside could easily be damaged during cover removal or replacement.
- **Do not load a damaged cartridge into a tape subsystem.** During an emergency, if you need to recover data from a damaged cartridge, call your service representative. (IBM will charge the customer for the time and materials used during a service call to recover information.)

Examples of cartridge damage are:

- The cartridge case is cracked or broken.
- The cartridge door is broken.
- The file-protect selector is damaged.

---

## Cartridge Labels

With the exception of the factory supplied label, user-supplied labels should not be affixed to the cartridge because they may interfere with the proper functioning of the cartridge in either the drive or the library transport mechanism.

The bar code label that comes attached to each cartridge has a small space in which you may write (see **3** in Figure 107 on page 162). Any information that you write on the label should be written only with markers that do not smear or leave a thick residue.

## Bar Code Format

- The bar code is seven characters in length not including the start/stop characters. The first character (left-most character) is the media type character and is an uppercase "G" for all C-Format Magstar MP cartridges and an uppercase "F" for all B-Format Magstar MP cartridges and the cleaning cartridge.
- The remaining six (right most) characters are used to uniquely identify the cartridges. The valid bar code characters are as follows:
  - Uppercase Alpha - A through Z.
  - Numeric - 0 through 9.
  - Blanks (or Spaces) - Trailing only.

The bar code can be any mixture of alpha and numeric characters such as the following:

- "GABC123" "GA1B2C3" "G123ABC".
- "G12345 " (with a trailing blank character).
- "GA3B " (with 3 trailing blank characters).
- The bar code is located on two labels on the Magstar MP cartridge. (See **1** and **2** in Figure 107 on page 162.)
- Some operating systems or applications, like ADSM and BRMS/400, only display the last six characters. (The "G" or "F" is not displayed.)
- For Standard Label tape processing using the Bar Code Reader, the bar code labels and internally recorded VOLSER must match. If there are existing

cartridges, in which there is a mismatch between the Bar Code Label and the VOLSER with which the tape was initialized, (see “Resolving a Mismatch Between the Bar Code Label and VOLSER” on page 135).

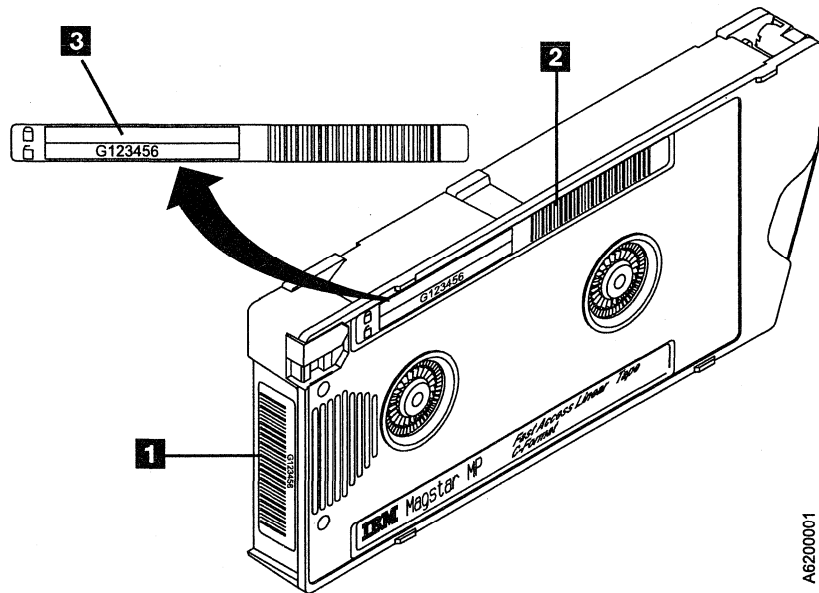

Figure 107. Magstar MP Tape Cartridge Labels

---

## Cartridge Label Cleaning

If cartridge labels become dirty, wipe them with a dry, lint-free cloth. Do **not** use water or any chemicals to clean the label.

---

## Cartridge Label Replacement

1. For Standard Label tape processing using the Bar Code Reader, the bar code labels and internally recorded VOLSER must match. If there are existing cartridges, in which there is a mismatch between the Bar Code Label and the VOLSER, with which the tape was initialized, see “Resolving a Mismatch Between the Bar Code Label and VOLSER” on page 135.
2. Carefully peel the old label off the cartridge. The old labels must be completely removed with no residue left behind in the recessed label area (remaining glue residue can be rubbed off with your hand).

**Note:** Do **not** use any sharp objects, water, or any other chemicals to clean the label areas of the cartridge.

3. Orient the labels on the cartridge, as shown in Figure 107.
4. Place the label completely over the recessed area. Make sure the label is flat and has no folds, missing pieces, tears, or extraneous markings, such as smears or stains.

**Note:** If the label is not placed properly, the Bar Code Reader cannot read the bar code. Misplaced labels may also interfere with the operation of the drive.

---

## Chapter 11. Cartridge Environmental Information

This section describes the operating, storage, and shipping environments recommended for Magstar MP Fast Access Linear Tape cartridges.

---

### Operating Environment

The operating environment for 3570 Tape Subsystems that use Magstar MP Fast Access Linear Tape cartridges is:

- 16°C to 32°C (60°F to 90°F) dry bulb.
- 8 to 80 percent relative humidity.
- 26°C (79°F) maximum wet bulb.
- 2133 meters (6979 feet) maximum altitude.

**Note:** Before you use a cartridge, condition it to the operating environment for a time equal to the time it was out of the operating environment up to a maximum of 24 hours. If the cartridge has been out of the operating environment for more than 24 hours, it is not necessary to condition it to the operating environment for more than 24 hours.

---

### Storage Environment

Until it is opened, the original shipping container is the best storage container for the cartridges. The plastic wrapping prevents contamination from accumulating on the cartridges and partially protects them from humidity changes.

The preferred orientation for cartridge storage is vertical.

Cartridges can be stored within the following temperature and humidity ranges:

- 1°C to 60°C (34°F to 140°F) dry bulb.
- 5 to 80 percent relative humidity.
- 29°C (84°F) maximum wet bulb.

**Note:** IBM does not recommend continuous, extended storage of the tape cartridges in the maximum temperature and humidity environment. However, if necessary, you can store the cartridges in the maximum condition environment for up to four weeks without damaging the data or the cartridge.

For additional information about storing magnetic tape, see the National Bureau of Standards publication listed under "Related Information" on page xxi

---

## Shipping Environment

When you ship a cartridge, place it in a sealed, moisture-proof bag to protect the cartridge from moisture, contaminants, and physical damage. Ship the cartridge in a shipping container with enough packing material to cushion the cartridge and to prevent the cartridge from moving inside the container.

If two or more cartridges are packed in the same container, the container should hold the cartridges firmly together so that the cartridge cases cannot rub against each other.

Unrecorded, packaged IBM cartridges can be exposed for up to 10 days to the following environment during shipment:

- -23°C to 49°C (-10°F to 120°F) dry bulb.
- 5 to 80 percent relative humidity.
- 29°C (84°F) maximum wet bulb.

Recorded, packaged IBM cartridges can be exposed to the following environment, not to exceed 10 days, without risk of damage during shipment:

- 4.4°C to 40°C (40°F to 104°F) dry bulb.
- 5 to 80 percent relative humidity.
- 29°C (84°F) maximum wet bulb.

---

## A. Media/Hardware Problem Isolation

An error code (FID FE) will be generated when the drive experiences an error and cannot determine if the error was caused by the tape cartridge or by a problem in the drive hardware. The FID FE is not displayed on the drive, but is logged in the sense information that is returned to the host system. If you receive an error when reading or writing to the drive and there is no FID displayed, then follow this procedure also.

Media or drives can affect each other and the indications can be confusing. You must record the symptoms for the drive and the tape to make problem isolation possible. The failing component or tape must be isolated or you will continue to experience problems. Problems can be intermittent so careful record keeping is a must. Keeping careful records of transient problems will enable problem isolation and resolution.

To determine the cause of the read or write errors, follow the steps below.

- Ensure that the tape drive is not overdue for cleaning.
  - For Model C00, clean it if the CLEAN LED is lit.
  - For a Library Model tape drive, ensure that the AUTO CLEAN option is ON, and a cleaner cartridge is installed.
- Determine which VOLSER#s or cartridges are potential problems.
  - Note which cartridges (VOLSER#s) fail during the operation. (It is possible to have multiple bad cartridges.)
  - On a 3570 Cxx drive, record the MIM MESSAGE CODE at the host and associated VOLSER#.
  - On a 3570 Cxx, if you receive SIM messages at the host, get VOLSER#s from the message and record those in your TAPE SERIAL LOG. (See Figure 108 on page 166 as an example of how to establish a log and what it should include.)
- Determine if the cartridges are bad.
  - Examine the cartridge for damage; for example, the leader block is not attached or you have a cracked cartridge. If damaged, either repair or replace the cartridge.

**Note:** A repaired cartridge may be used long enough to recover data on that cartridge. When the data has been recovered, the cartridge should then be taken out of service and discarded or returned to the plant of origin.
  - If the cartridges look OK, and you have access to another 3570, try the operation with the suspect cartridges in another 3570. If your cartridges fail in the other 3570, replace the media and save your bad media for replacement.
- Determine if the drive is bad.
  - Try a new tape on the suspect drive. Log all failure data on your DRIVE LOG (see Figure 109 on page 166 as an example of how to establish a log and what it should include), and try one more tape. If it also fails, call for service.

- If only one tape fails, then log the information on both the Figure 109 on page 166 and the Figure 108 on page 166 for future reference.
- If tapes show evidence of damage, do not put any more tapes on the drive until service has examined the drive.

*Figure 108. Tape Serial Log*

Failure Date	Drive	Failure Code Unknown	Failure Code FE	Failure Code F0	Failure Code F1	Failure Code D3	Failure Code (other)
9/11/98	Drive 1	1	1	1			
9/16/98	Drive 2	1	1			1	B3
10/xx/xx							
10/xx/xx							
10/xx/xx							
10/xx/xx							
10/xx/xx							

*Figure 109. Drive Log*

Log Item	Drive 1	Drive 2
BE Error 4 tapes	9/9/98 call for service	
AB Error 1 tape	9/14/98 record tape serial	
Load failure		serial 123456 9/18/98
x		
x		
x		
x		

## Statement of Limited Warranty

*The warranties provided by IBM in this Statement of Limited Warranty apply only to Machines you originally purchase for your use, and not for resale, from IBM or your reseller. The term "Machine" means an IBM machine, its features, conversions, upgrades, elements, or accessories, or any combination of them. Unless IBM specifies otherwise, the following warranties apply only in the country where you acquire the Machine. If you have any questions, contact IBM or your reseller.*

**Machine:** IBM Magstar MP 3570 3570 Tape Subsystem  
**Warranty Period\*:** Three years \*Contact your place of purchase for warranty service information.

### Production Status

Each Machine is manufactured from new parts, or new and used parts. In some cases, the Machine may not be new and may have been previously installed. Regardless of the Machine's production status, IBM's warranty terms apply.

### The IBM Warranty for Machined

IBM warrants that each Machine 1) is free from defects in materials and workmanship and 2) conforms to IBM's Official Published Specifications. The warranty period for a Machine is a specified, fixed period commencing on its Date of Installation. The date on your receipt is the Date of Installation, unless IBM or your reseller informs you otherwise.

During the warranty period, IBM or your reseller, if authorized by IBM, will provide warranty service under the type of service designated for the Machine and will manage and install engineering changes that apply to the Machine.

For IBM or your reseller to provide warranty service for a feature, conversion, or upgrade, IBM or your reseller may require that the Machine on which it is installed be 1) for certain Machines, the designated, serial-numbered Machine and 2) at an engineering-change level compatible with the feature, conversion, or upgrade. Many of these transactions involve the removal of parts and their return to IBM. A part that replaces a removed part will assume the remaining warranty service status of the replaced part. You represent that all removed items are genuine and unaltered. When a type of service involves the exchange of a Machine or part, the item IBM or your reseller replaces becomes its property and the replacement becomes yours.

If a Machine does not function as warranted during the warranty period, IBM or your reseller will repair it or replace it with one that is at least functionally equivalent, without charge. The replacement may not be new, but will be in good working order. If IBM or your reseller is unable to repair or replace the Machine, you may return it to your place of purchase and your money will be refunded.

If you transfer a Machine to another user, warranty service is available to that user for the remainder of the warranty period. You should give your proof of purchase and this Statement to that user. However, for Machines which have a life-time warranty, this warranty is not transferable.

### Warranty Service

To obtain warranty service for the Machine, you should contact your reseller or call IBM. In the United States, call IBM at **1-800-IBM-SERV (426-7378)**. In Canada, call IBM at **1-800-465-6666**. You may be required to present proof of purchase.

IBM or your reseller will provide certain types of repair and exchange service, either at your location or at IBM's or your reseller's service center, to restore a Machine to good working order.

When a type of service involves the exchange of a Machine or part, the item IBM or your reseller replaces becomes its property and the replacement becomes yours. The replacement may not be new, but will be in good working order and at least functionally equivalent to the item replaced. Before IBM or your reseller exchanges a Machine or part, you agree to remove all features, parts, options, alterations, and attachments not under warranty service. You also agree to ensure that the Machine is free of any legal obligations or restrictions that prevent its exchange. You agree to:

1. obtain authorization from the owner to have IBM or your reseller service a Machine that you do not own; and
2. where applicable, before service is provided —
  - a. follow the problem determination, problem analysis, and service request procedures that IBM or your reseller provide,
  - b. secure all programs, data, and funds contained in a Machine, and
  - c. inform IBM or your reseller of changes in a Machine's location.

IBM is responsible for loss of, or damage to, your Machine while it is 1) in IBM's possession or 2) in

transit in those cases where IBM is responsible for the transportation charges.

#### **Extent of Warranty**

IBM does not warrant uninterrupted or error-free operation of a Machine.

The warranties may be voided by misuse, accident, modification, unsuitable physical or operating environment, improper maintenance by you, removal or alteration of Machine or parts identification labels, or failure caused by a product for which IBM is not responsible.

THESE WARRANTIES REPLACE ALL OTHER WARRANTIES OR CONDITIONS, EXPRESS OR IMPLIED, INCLUDING, BUT NOT LIMITED TO, THE IMPLIED WARRANTIES OR CONDITIONS OF MERCHANTABILITY AND FITNESS FOR A PARTICULAR PURPOSE. THESE WARRANTIES GIVE YOU SPECIFIC LEGAL RIGHTS AND YOU MAY ALSO HAVE OTHER RIGHTS WHICH VARY FROM JURISDICTION TO JURISDICTION. SOME JURISDICTIONS DO NOT ALLOW THE EXCLUSION OR LIMITATION OF EXPRESS OR IMPLIED WARRANTIES, SO THE ABOVE EXCLUSION OR LIMITATION MAY NOT APPLY TO YOU. IN THAT EVENT SUCH WARRANTIES ARE LIMITED IN DURATION TO THE WARRANTY PERIOD. NO WARRANTIES APPLY AFTER THAT PERIOD.

#### **Limitation of Liability**

Circumstances may arise where, because of a default on IBM's part or other liability you are entitled to recover damages from IBM. In each such instance, regardless of the basis on which you are entitled to claim damages from IBM (including fundamental breach of contract, negligence, misrepresentation, or other contract or tort claim), IBM is liable only for:

1. damages for bodily injury (including death) and damage to real property and tangible personal property; and
2. the amount of any other actual direct damages or loss, up to the greater of U.S. \$100,000 or the charges (if recurring, 12 months' charges apply) for the Machine that is the subject of the claim.

UNDER NO CIRCUMSTANCES IS IBM LIABLE FOR ANY OF THE FOLLOWING: 1) THIRD-PARTY CLAIMS AGAINST YOU FOR LOSSES OR DAMAGES (OTHER THAN THOSE UNDER THE FIRST ITEM LISTED ABOVE); 2) LOSS OF, OR DAMAGE TO, YOUR RECORDS OR DATA; OR 3) SPECIAL, INCIDENTAL, OR INDIRECT DAMAGES OR FOR ANY ECONOMIC CONSEQUENTIAL DAMAGES (INCLUDING LOST PROFITS OR SAVINGS), EVEN IF IBM OR YOUR RESELLER IS INFORMED OF THEIR POSSIBILITY. SOME JURISDICTIONS DO NOT ALLOW THE EXCLUSION OR LIMITATION OF INCIDENTAL OR CONSEQUENTIAL DAMAGES, SO THE ABOVE EXCLUSION OR LIMITATION MAY NOT APPLY TO YOU.

International Business Machines Corporation

Armonk, New York 10504, U.S.A.



---

# Glossary

This glossary defines the special terms, abbreviations, and acronyms that are used in this publication. If you do not find the term you are looking for, refer to the *Dictionary of Computing*, New York: McGraw-Hill, 1994.

## A

**AEN.** See *asynchronous event notification*.

**archiving.** The storage of backup files and associated journals, usually for a given period.

**archiving application.** The retention of records, in machine-readable form, for historical purposes.

**asynchronous event notification (AEN).** The ability of a device to initiate communications with attached hosts.

**automatic mode.** A mode of operation that can be selected on the cartridge loader. This mode allows the automatic feeding and loading of premounted tape cartridges requiring no operator action.

## B

**backup and recovery application.** The short-term retention of records used for restoring essential business and system files when vital data has been lost because of program or system errors or malfunctions.

**bit.** A binary digit that may have the value of either 0 or 1.

**block.** A collection of contiguous data recorded as a unit.

**buffer.** A routine or storage used to compensate for a difference in the rate of flow of data, or time of occurrence of events, when transferring data from one device to another.

**buffered mode.** A mode that allows some logical blocks to accumulate in a buffer before the data is transferred to the device or bus.

**byte.** A binary number containing exactly eight bits.

## C

**capacity of media.** The amount of data that can be contained on storage media and expressed in bytes of data.

**cartridge loader.** A standard function for the tape drive. It allows the automatic loading of premounted tape cartridges or the manual loading of single tape cartridges.

**command.** Control information that initiates an action or the beginning of a sequence of actions.

**conversion.** The process of changing from one method of data processing to another or from one data-processing system to another.

## D

**data.** Any representations such as characters or analog quantities to which meaning is, or might be, assigned.

**data base.** A set of data, consisting of at least one file, that is sufficient for a given purpose or for a given data-processing system.

**data compression.** A technique or algorithm used to encode a quantity of data such that the encoded result can normally be stored in less space than the original data and such that the original data can be recovered from the encoded result through a reverse technique or reverse algorithm.

**device driver.** A technique for moving data between processor storage and input/output devices.

**drive ready.** A condition of a tape drive in which a tape cartridge has been inserted in the drive, and the tape has been threaded to the beginning-of-tape position.

**dump.** To write the contents of storage, or a part of storage, usually from an internal storage to an external medium, for a specific purpose such as to allow other use of storage, as a safeguard against faults or errors, or with debugging.

**dual-drive library.** A library with two tape drives.

## E

**effective data rate.** The average number of bits, bytes, characters, or blocks per unit time transferred from a data source to a data sink and accepted as valid. The rate is expressed in bits, bytes, characters, or blocks per second, minute, or hour.

**EIA.** A unit of measure established by the Electronics Industry Association equal to 44.45 mm (1.75 in).

**enable.** To provide the means or opportunity. The modification of system, control unit, or device action through the change of a software module or a hardware switch (circuit jumper) position.

**error-recovery procedures (ERP).** Procedures designed to help isolate and, where possible, to recover from errors in equipment. The procedures are often used with programs that record the statistics of machine malfunctions.

## F

**FC.** Feature code.

**FID.** Field Replaceable Unit (FRU) Identifier. FIDs are codes that are associated with error messages and each one indicates a specific problem condition. When a service call is made, the FID code should be given to your service representative.

**file.** A set of related records, treated as a unit. For example, in stock control, a file could consist of a set of invoices.

**file protected.** Pertaining to a tape volume from which data can be read only. Data cannot be written on the tape.

**format.** The arrangement or layout of data on a data medium.

**formatted tape volume.** A tape volume that has been initialized with certain formatting information (servo tracks) that is required to exist for the recording technique used on the volume before any data can be recorded. Depending on the format and media, formatting may or may not be required to use the media for data-recording purposes.

## G

**GB.** Gigabyte; 1 000 000 000 bytes of storage.

## I

**index.** A function performed by the cartridge loader that moves cartridges down the input or output stack one cartridge position. A loader can perform multiple consecutive indexes.

**initiator.** A SCSI device that requests an I/O process to be performed by another SCSI device (a target). In many cases, an initiator can also be a target.

**install.** To set up for use or service. The act of adding a product, feature, or function to a system or device either by a singular change or by the addition of multiple components or devices.

**interchange.** The ability to process (read or write) a given tape volume on any one of a set of tape devices that support the form factor and recording format on the tape volume.

**interchange application.** The preparation of tapes for use on other systems or devices, either local or remote, or the use of tape data prepared by another system.

**interposer.** An interposer is a part used to convert a 68-pin connector to a 50-pin D-shell connector.

**I/O.** Input/output.

## L

**label.** A label is a control file that is associated with a data file that provides volume and file identification information. The label is a software construct that appears as any other file to the I/O subsystem.

**load point.** The beginning of the recording area on magnetic tape.

**logical block.** A logical block is an independently accessible unit of information created by the program within a file. A logical block may be either a data logical block or a mark logical block.

**logical record.** A logical record is a string of concatenated data bytes that is passed between an application program and a control program or access method as the result of an I/O request.

**loader.** A standard function for the tape drive. It allows the automatic loading of premounted tape cartridges or the manual loading of single tape cartridges.

**load point.** The beginning of the recording area on magnetic tape.

**LZ-1.** Lempel-Ziv data compression program.

## M

**magnetic recording.** A technique of storing data by selectively magnetizing portions of a magnetizable material.

**magnetic tape.** A tape with a magnetizable surface layer on which data can be stored by magnetic recording.

**magnetic tape drive.** A mechanism for moving magnetic tape and controlling its movement.

**manual (sequential) mode.** A mode of operation that can be selected on the cartridge loader. This mode allows a single tape cartridge feed performed by the operator.

**MB.** Megabyte; 1 000 000 bytes of storage.

**media capacity.** The amount of data that can be contained on storage media and expressed in bytes of data.

**microprocessor.** An integrated circuit that accepts coded instructions for execution. The instructions may be entered, integrated, or stored internally.

**microprogram.** (1) A sequence of elementary instructions that correspond to a specific computer operation, that is maintained in special storage, and whose execution is initiated by the introduction of a computer instruction into the instruction register of a computer. (2) A group of micro instructions that when executed perform a preplanned function.

**migration.** The process of changing from one method of data processing to another or from one data-processing system to another.

**mount.** The act of making a tape volume available for processing by a specific tape device.

**mounted.** The state of a tape volume while it is available for processing by a specific tape device.

**MP.** Multi-Purpose. Designates the suitability of the Magstar MP 3570 Tape Subsystem for a wide variety of applications beyond those for which tape subsystems are ordinarily used. This designation is based on the high-performance characteristics, of the Magstar MP system, the most notable being the unit's high speed.

## P

**physical-write protection.** A facility provided by the mechanical housing of the tape volume that allows a human being or robotics device to write protect a tape volume. Physical-write protection persists until the state of the facility on the tape volume is changed.

**processing application.** The execution of a systematic sequence of operations performed on data to accomplish a specific purpose.

## Q

**quiesce.** To bring a device or system to a halt by a rejection of new requests for work.

## R

**random access.** Random access refers to the processing of information on a volume in a manner that requires the device to access nonconsecutive storage locations on the medium.

**removable media.** Recording media that can be added to or removed from a recording device.

## S

**SCSI.** Small computer system interface.

**SCSI address.** The hexadecimal representation of the unique address (0-F) assigned to a SCSI device. This address would normally be assigned and set in the SCSI device during system installation.

**SCSI device.** A host adapter or a target controller that can be attached to a SCSI bus.

**sequential access.** Refers to the processing of information on a volume in a manner that requires the device to access consecutive storage locations (logical blocks) on the medium.

**sequential mode.** See *automatic mode* or *manual mode*.

**ship group.** The group of supplies, cords, or documentation that is shipped with the machine.

**special feature.** A specific design addition to an IBM product that is quoted in the IBM Sales Manual and ordered separately.

**standard function.** The significant design elements of an IBM product that are included as part of the basic standard product.

## T

**tape cartridge.** A container holding magnetic tape that can be processed without separating it from the container.

**tape volume.** The recording medium and associated mechanical package that houses the media used by a tape device. See also *volume*.

**target.** A SCSI device that performs an operation requested by the initiator. A target can also be an initiator.

**terminator.** A part used to end a SCSI bus.

## V

**volume.** (1) A certain portion of data, together with its data carrier, that can be handled conveniently as a unit. (2) A data carrier that is mounted and demounted as a unit, for example, a tape cartridge.

## W

**write protected.** A tape volume is write protected if some logical or physical mechanism causes the device processing the tape volume to prevent the program from writing on the volume.

---

# Index

## A

Adaptec Adapter  
  installation 104  
  verify installation 104  
additional cartridges, how to order 17, 47  
additional publications xx  
address, SCSI 19, 55, 101  
attaching the pedestal 18, 48  
attention message 141, 142  
attention notice xiii  
automatic (sequential) mode 116

## B

bar code reader  
  resolving mismatch 135  
Base Configuration 117

## C

cable feature code (part number), SCSI 21, 58  
cartridge, tape  
  cleaning 6, 34  
  damaged 161  
  degaussing 160  
  disposal 160  
  file-protect selector 5  
  handling 159  
  how to order 17, 47  
  how to unload 125  
  label 161, 162  
  loading 31  
  magazine 7  
  recording format 5  
  removing 32  
  stacking 159  
  stuck, how to remove 32  
  unloading 31  
  unpacking 159  
caution notice xii  
change language menu 150  
change mode menu 152  
clean LED indicator 30  
clean menu 152  
cleaning cartridge 6, 34, 130  
cleaning the tape path 34, 129  
code for SCSI cable, feature 21, 58  
code, power cord feature 16, 45  
compression, data 8  
configuration of the subsystem 55, 101  
Configuration, library  
  base 55, 61, 101, 109, 117, 132, 140, 148

Configuration, library (*continued*)  
  split 55, 61, 101, 109, 117, 132, 140, 148  
confirm mode change menu 152  
connection to the host 21, 58, 108  
contaminants, inspecting for 160  
controls and indicators 29  
conversion 3  
customer installed rack-mounted models 73

## D

damaged cartridges 161  
danger notice xii  
data rate, sustained 8  
data transfer rate 1, 8  
degaussing, cartridge 160  
disposal, cartridge 160  
drive door 30  
drive indicators 29  
drive, stand-alone Model C00  
  device type 3  
  installation procedure 13  
  overview 5

## E

effective data rate 8  
EIA unit 76  
end of life (EOL) plan xiv  
environment  
  operating 163  
  shipping 164  
  storage 163  
environmental design xiv  
environmental notice xiv  
export position, cartridge magazine 7, 124

## F

fast access linear tape cartridge, Magstar MP 5  
feature code (FC), power cord 16, 45  
feature code, SCSI cable 21, 58  
file-protect selector 5  
flowchart of operator menus 143  
front assembly 49  
front panel 121

## H

handling the cartridges 159  
hazard, safety xiii  
host connection 21, 58, 108

**I**  
import position, cartridge magazine 7, 124  
indicator, drive 29  
indicator, LED 30  
information, additional xx  
initiator connection 21, 58, 108  
initiator, SCSI 19  
inserting a magazine 126  
inspecting for contaminants 160  
installation procedure  
    checklist 16, 45  
    Model C00 13  
    Model C01 41  
    Model C11 41  
interface, SCSI 19  
interposer  
    AS/400 16, 45  
    feature code 16, 45  
    part number 16, 45  
    RISC System/6000 16, 45  
intervention screen 141

**K**  
keys, location and ordering 46

**L**  
label, cartridge 161  
language menu, change 150  
LED indicator 30  
library Models C01, C02, C11, and C12  
    conversion 3  
    device type 3  
    overview 5  
limited warranty 167  
loading a cartridge 31, 125, 128  
loading, maintenance cycle for 31  
location restriction 18, 48

**M**  
magazine, cartridge 7  
magazine, how to insert or remove 126  
magazine, tape cartridge 159  
Magstar MP 3570 Tape Subsystem, overview 5  
maintenance cycle 31  
maintenance LED indicator 30  
manual (sequential) mode 116  
manual procedure for cleaning cartridges 130  
menu  
    change language 150  
    clean 152  
    confirm mode change 152  
    operator 145  
    options 145

menu (*continued*)  
    SCSI ID (set address) 148  
    services 150  
    set address (SCSI ID) 148  
    set library mode 2 147  
    show statistics 151  
    statistics 151  
message screen, supplemental 143  
message, ATTENTION 142  
mode change menu 152  
mode of operation 7, 115, 116  
mode selection 131  
Model C00  
    device type 3  
    installation procedure 13  
    overview 5  
Model C01  
    conversion 3  
    device type 3  
    overview 5  
Model C02  
    conversion 3  
    device type 3  
    overview 5  
Model C11  
    conversion 3  
    device type 3  
    overview 5  
Model C12  
    conversion 3  
    device type 3  
    overview 5  
Model C1A  
    conversion 3  
    reference xix  
Model C21  
    Adaptec Card installation 104  
    device type 3  
    front assembly 95  
    install into rack 82  
    installation 73  
    installation verification 95  
    overview 5  
    SCSI and power cable attach 85  
    verify Adaptec Card installation 104  
Model C22  
    Adaptec Card installation 104  
    device type 3  
    front assembly 95  
    install into rack 82  
    installation 73  
    installation verification 95  
    overview 5  
    SCSI and power cable attach 85  
    verify Adaptec Card installation 104

moving a subsystem 27, 71, 113

## N

### NETBAY22

Models C21 and C22 installation 1

Netfinity 1, 2

3570 installation 1

Model C21 device type 3

Model C22 device type 3

Models C21 and C22 installation 1

notice, caution xii

number for cartridge, part 17, 47

number for SCSI cable, part 21, 58

number, power cord part 16, 45

## O

operating environment, 3570 Tape Subsystem 163

operation, mode of 7, 115, 116

operator controls and indicators 29

operator menu 145

operator panel 135

options menu 145

order additional cartridges 17, 47

overview, Magstar MP 3570 Tape Subsystem 5

## P

panel, front 121

panel, operator 135

part number, power cord 16, 45

part number, SCSI cable 21, 58

pedestal, how to attach 18, 48

position, cartridge import or export 7, 124

power on/off switch 29

pre-installation procedure 16, 45

procedure, unpacking 45, 159

processing speed, tape 8

product recycling xiv

protect selector, file 5

publications, additional xx

## R

rack-mount

EIA location 76

left-hand slide and bracket install 79

Model C21 install 82

Model C22 install 82

right-hand slide and bracket install 80

rack-mount installation 73

random mode 115

rate, data transfer 1

reader comments xi

recording format, cartridge 5

recover status 133

recycling, product xiv

relocating a subsystem 27, 71, 113

removing a magazine 126

removing a stuck cartridge 129

removing a subsystem 27, 71, 113

replacing labels 162

restriction, location 18, 48

routine message 142

## S

safety hazard xiii

safety notice xi

screen

intervention 141

menu 143

status 137

supplemental message 143

SCSI address, how to set 19, 55, 101

SCSI cable, feature code (part number) 21, 58

SCSI ID (set address) menu 148

selection, mode 131

selector, file-protect 5

sequential mode 116

services menu 150

set address (SCSI ID) menu 148

setting the SCSI address 55, 101

shipping environment, 3570 Tape Subsystem 164

show statistics menu 151

speed, tape processing 8

Split Configuration 118

stacking the cartridges 159

stand-alone drive Model C00

device type 3

installation procedure 13

overview 5

statistics menu 151

status screen 137

storage environment, 3570 Tape Subsystem 163

stuck cartridge, how to remove 32, 129

subsystem configuration 55, 101

subsystem, location restriction of 48

summary, Magstar MP 3570 Tape Subsystem 5

supplemental message screen 143

sustained data rate 8

## T

tape busy LED indicator 29

tape cartridge 159

tape cartridge, fast access linear

cleaning 6, 34

damaged 161

degaussing 160

disposal 160

tape cartridge, fast access linear (*continued*)

- handling 159
- how to order 17, 47
- how to unload 125
- label 161, 162
- loading 31
- magazine 7
- recording format 5
- removing 32
- stacking 159
- stuck, how to remove 32
- unloading 31
- unpacking 159

tape magazine 159

tape path, cleaning 34, 129

tape unload button 29

terminator, SCSI 19

terminology 169

trademarks xiv

transfer rate, data 1, 8

## U

- unloading a cartridge 31, 128
- unpacking procedure 45, 159
- upgrade 3



---

# Readers' Comments — We'd Like to Hear from You

Magstar MP 3570 Tape Subsystem  
Operator Guide  
C-Series Models  
Publication No. GA32-0393-01

Overall, how satisfied are you with the information in this book?

	Very Satisfied	Satisfied	Neutral	Dissatisfied	Very Dissatisfied
Overall satisfaction	<input type="checkbox"/>	<input type="checkbox"/>	<input type="checkbox"/>	<input type="checkbox"/>	<input type="checkbox"/>

How satisfied are you that the information in this book is:

	Very Satisfied	Satisfied	Neutral	Dissatisfied	Very Dissatisfied
Accurate	<input type="checkbox"/>	<input type="checkbox"/>	<input type="checkbox"/>	<input type="checkbox"/>	<input type="checkbox"/>
Complete	<input type="checkbox"/>	<input type="checkbox"/>	<input type="checkbox"/>	<input type="checkbox"/>	<input type="checkbox"/>
Easy to find	<input type="checkbox"/>	<input type="checkbox"/>	<input type="checkbox"/>	<input type="checkbox"/>	<input type="checkbox"/>
Easy to understand	<input type="checkbox"/>	<input type="checkbox"/>	<input type="checkbox"/>	<input type="checkbox"/>	<input type="checkbox"/>
Well organized	<input type="checkbox"/>	<input type="checkbox"/>	<input type="checkbox"/>	<input type="checkbox"/>	<input type="checkbox"/>
Applicable to your tasks	<input type="checkbox"/>	<input type="checkbox"/>	<input type="checkbox"/>	<input type="checkbox"/>	<input type="checkbox"/>

Please tell us how we can improve this book:

Thank you for your responses. May we contact you?  Yes  No

When you send comments to IBM, you grant IBM a nonexclusive right to use or distribute your comments in any way it believes appropriate without incurring any obligation to you.

\_\_\_\_\_  
Name

\_\_\_\_\_  
Address

\_\_\_\_\_  
Company or Organization

\_\_\_\_\_

\_\_\_\_\_  
Phone No.

\_\_\_\_\_



Cut or  
Along L

Fold and Tape

Please do not staple

Fold and Tape

PLACE  
POSTAGE  
STAMP  
HERE

International Business Machine Corporation  
Department 61C 9000 South Rita Road  
Tucson, AZ 85741-0001, U.S.A.

Fold and Tape

Please do not staple

Fold and Tape

Cut or  
Along

---

# Readers' Comments — We'd Like to Hear from You

Magstar MP 3570 Tape Subsystem  
Operator Guide  
C-Series Models  
Publication No. GA32-0393-01

Overall, how satisfied are you with the information in this book?

	Very Satisfied	Satisfied	Neutral	Dissatisfied	Very Dissatisfied
Overall satisfaction	<input type="checkbox"/>	<input type="checkbox"/>	<input type="checkbox"/>	<input type="checkbox"/>	<input type="checkbox"/>

How satisfied are you that the information in this book is:

	Very Satisfied	Satisfied	Neutral	Dissatisfied	Very Dissatisfied
Accurate	<input type="checkbox"/>	<input type="checkbox"/>	<input type="checkbox"/>	<input type="checkbox"/>	<input type="checkbox"/>
Complete	<input type="checkbox"/>	<input type="checkbox"/>	<input type="checkbox"/>	<input type="checkbox"/>	<input type="checkbox"/>
Easy to find	<input type="checkbox"/>	<input type="checkbox"/>	<input type="checkbox"/>	<input type="checkbox"/>	<input type="checkbox"/>
Easy to understand	<input type="checkbox"/>	<input type="checkbox"/>	<input type="checkbox"/>	<input type="checkbox"/>	<input type="checkbox"/>
Well organized	<input type="checkbox"/>	<input type="checkbox"/>	<input type="checkbox"/>	<input type="checkbox"/>	<input type="checkbox"/>
Applicable to your tasks	<input type="checkbox"/>	<input type="checkbox"/>	<input type="checkbox"/>	<input type="checkbox"/>	<input type="checkbox"/>

Please tell us how we can improve this book:

Thank you for your responses. May we contact you?  Yes  No

When you send comments to IBM, you grant IBM a nonexclusive right to use or distribute your comments in any way it believes appropriate without incurring any obligation to you.

\_\_\_\_\_  
Name

\_\_\_\_\_  
Address

\_\_\_\_\_  
Company or Organization

\_\_\_\_\_

\_\_\_\_\_  
Phone No.

\_\_\_\_\_



Cut or  
Along

Fold and Tape

Please do not staple

Fold and Tape

PLACE  
POSTAGE  
STAMP  
HERE

International Business Machine Corporation  
Department 61C 9000 South Rita Road  
Tucson, AZ 85741-0001, U.S.A.

Fold and Tape

Please do not staple

Fold and Tape

Cut o  
Along

---

# Readers' Comments — We'd Like to Hear from You

**Magstar MP 3570 Tape Subsystem**

**Operator Guide**

**C-Series Models**

**Publication No. GA32-0393-01**

**Overall, how satisfied are you with the information in this book?**

	Very Satisfied	Satisfied	Neutral	Dissatisfied	Very Dissatisfied
Overall satisfaction	<input type="checkbox"/>	<input type="checkbox"/>	<input type="checkbox"/>	<input type="checkbox"/>	<input type="checkbox"/>

**How satisfied are you that the information in this book is:**

	Very Satisfied	Satisfied	Neutral	Dissatisfied	Very Dissatisfied
Accurate	<input type="checkbox"/>	<input type="checkbox"/>	<input type="checkbox"/>	<input type="checkbox"/>	<input type="checkbox"/>
Complete	<input type="checkbox"/>	<input type="checkbox"/>	<input type="checkbox"/>	<input type="checkbox"/>	<input type="checkbox"/>
Easy to find	<input type="checkbox"/>	<input type="checkbox"/>	<input type="checkbox"/>	<input type="checkbox"/>	<input type="checkbox"/>
Easy to understand	<input type="checkbox"/>	<input type="checkbox"/>	<input type="checkbox"/>	<input type="checkbox"/>	<input type="checkbox"/>
Well organized	<input type="checkbox"/>	<input type="checkbox"/>	<input type="checkbox"/>	<input type="checkbox"/>	<input type="checkbox"/>
Applicable to your tasks	<input type="checkbox"/>	<input type="checkbox"/>	<input type="checkbox"/>	<input type="checkbox"/>	<input type="checkbox"/>

**Please tell us how we can improve this book:**

Thank you for your responses. May we contact you?  Yes  No

When you send comments to IBM, you grant IBM a nonexclusive right to use or distribute your comments in any way it believes appropriate without incurring any obligation to you.

\_\_\_\_\_  
Name

\_\_\_\_\_  
Address

\_\_\_\_\_  
Company or Organization

\_\_\_\_\_  
Phone No.



Cut or  
Along

Fold and Tape

**Please do not staple**

Fold and Tape

PLACE  
POSTAGE  
STAMP  
HERE

International Business Machine Corporation  
Department 61C 9000 South Rita Road  
Tucson, AZ 85741-0001, U.S.A.

Fold and Tape

**Please do not staple**

Fold and Tape

Cut or  
Along

---

# Readers' Comments — We'd Like to Hear from You

**Magstar MP 3570 Tape Subsystem  
Operator Guide  
C-Series Models  
Publication No. GA32-0393-01**

**Overall, how satisfied are you with the information in this book?**

	Very Satisfied	Satisfied	Neutral	Dissatisfied	Very Dissatisfied
Overall satisfaction	<input type="checkbox"/>	<input type="checkbox"/>	<input type="checkbox"/>	<input type="checkbox"/>	<input type="checkbox"/>

**How satisfied are you that the information in this book is:**

	Very Satisfied	Satisfied	Neutral	Dissatisfied	Very Dissatisfied
Accurate	<input type="checkbox"/>	<input type="checkbox"/>	<input type="checkbox"/>	<input type="checkbox"/>	<input type="checkbox"/>
Complete	<input type="checkbox"/>	<input type="checkbox"/>	<input type="checkbox"/>	<input type="checkbox"/>	<input type="checkbox"/>
Easy to find	<input type="checkbox"/>	<input type="checkbox"/>	<input type="checkbox"/>	<input type="checkbox"/>	<input type="checkbox"/>
Easy to understand	<input type="checkbox"/>	<input type="checkbox"/>	<input type="checkbox"/>	<input type="checkbox"/>	<input type="checkbox"/>
Well organized	<input type="checkbox"/>	<input type="checkbox"/>	<input type="checkbox"/>	<input type="checkbox"/>	<input type="checkbox"/>
Applicable to your tasks	<input type="checkbox"/>	<input type="checkbox"/>	<input type="checkbox"/>	<input type="checkbox"/>	<input type="checkbox"/>

**Please tell us how we can improve this book:**

Thank you for your responses. May we contact you?  Yes  No

When you send comments to IBM, you grant IBM a nonexclusive right to use or distribute your comments in any way it believes appropriate without incurring any obligation to you.

\_\_\_\_\_  
Name

\_\_\_\_\_  
Address

\_\_\_\_\_  
Company or Organization

\_\_\_\_\_

\_\_\_\_\_  
Phone No.

\_\_\_\_\_



Fold and Tape

Please do not staple

Fold and Tape

PLACE  
POSTAGE  
STAMP  
HERE

International Business Machine Corporation  
Department 61C 9000 South Rita Road  
Tucson, AZ 85741-0001, U.S.A.

Fold and Tape

Please do not staple

Fold and Tape



---

# Readers' Comments — We'd Like to Hear from You

Magstar MP 3570 Tape Subsystem  
Operator Guide  
C-Series Models

Publication No. GA32-0393-01

Overall, how satisfied are you with the information in this book?

	Very Satisfied	Satisfied	Neutral	Dissatisfied	Very Dissatisfied
Overall satisfaction	<input type="checkbox"/>	<input type="checkbox"/>	<input type="checkbox"/>	<input type="checkbox"/>	<input type="checkbox"/>

How satisfied are you that the information in this book is:

	Very Satisfied	Satisfied	Neutral	Dissatisfied	Very Dissatisfied
Accurate	<input type="checkbox"/>	<input type="checkbox"/>	<input type="checkbox"/>	<input type="checkbox"/>	<input type="checkbox"/>
Complete	<input type="checkbox"/>	<input type="checkbox"/>	<input type="checkbox"/>	<input type="checkbox"/>	<input type="checkbox"/>
Easy to find	<input type="checkbox"/>	<input type="checkbox"/>	<input type="checkbox"/>	<input type="checkbox"/>	<input type="checkbox"/>
Easy to understand	<input type="checkbox"/>	<input type="checkbox"/>	<input type="checkbox"/>	<input type="checkbox"/>	<input type="checkbox"/>
Well organized	<input type="checkbox"/>	<input type="checkbox"/>	<input type="checkbox"/>	<input type="checkbox"/>	<input type="checkbox"/>
Applicable to your tasks	<input type="checkbox"/>	<input type="checkbox"/>	<input type="checkbox"/>	<input type="checkbox"/>	<input type="checkbox"/>

Please tell us how we can improve this book:

Thank you for your responses. May we contact you?  Yes  No

When you send comments to IBM, you grant IBM a nonexclusive right to use or distribute your comments in any way it believes appropriate without incurring any obligation to you.

Name \_\_\_\_\_ Address \_\_\_\_\_

Company or Organization \_\_\_\_\_

Phone No. \_\_\_\_\_



Cut o  
Along

Fold and Tape

Please do not staple

Fold and Tape

PLACE  
POSTAGE  
STAMP  
HERE

International Business Machine Corporation  
Department 61C 9000 South Rita Road  
Tucson, AZ 85741-0001, U.S.A.

Fold and Tape

Please do not staple

Fold and Tape

Cut o  
Along





Printed in the United States of America  
on recycled paper containing 10%  
recovered post-consumer fiber.

GA32-0393-01

